



National
Qualifications
2025

X857/75/02

Physics
Section 1 — Questions

THURSDAY, 15 MAY

1:00 PM – 3:30 PM

Instructions for the completion of Section 1 are given on *page 02* of your question and answer booklet X857/75/01.

Record your answers on the answer grid on *page 03* of your question and answer booklet.

Reference may be made to the data sheet on *page 02* of this booklet and to the relationships sheet X857/75/11.

Before leaving the examination room you must give your question and answer booklet to the Invigilator; if you do not, you may lose all the marks for this paper.



* X 8 5 7 7 5 0 2 *

DATA SHEET

Speed of light in materials

Material	Speed in m s^{-1}
Air	3.0×10^8
Carbon dioxide	3.0×10^8
Diamond	1.2×10^8
Glass	2.0×10^8
Glycerol	2.1×10^8
Water	2.3×10^8

Speed of sound in materials

Material	Speed in m s^{-1}
Aluminium	5200
Air	340
Bone	4100
Carbon dioxide	270
Glycerol	1900
Muscle	1600
Steel	5200
Tissue	1500
Water	1500

Gravitational field strengths

	Gravitational field strength on the surface in N kg^{-1}
Earth	9.8
Jupiter	23
Mars	3.7
Mercury	3.7
Moon	1.6
Neptune	11
Saturn	9.0
Sun	270
Uranus	8.7
Venus	8.9

Specific heat capacity of materials

Material	Specific heat capacity in $\text{J kg}^{-1} \text{ }^\circ\text{C}^{-1}$
Alcohol	2350
Aluminium	902
Copper	386
Glass	500
Ice	2100
Iron	480
Lead	128
Oil	2130
Water	4180

Specific latent heat of fusion of materials

Material	Specific latent heat of fusion in J kg^{-1}
Alcohol	0.99×10^5
Aluminium	3.95×10^5
Carbon dioxide	1.80×10^5
Copper	2.05×10^5
Iron	2.67×10^5
Lead	0.25×10^5
Water	3.34×10^5

Melting and boiling points of materials

Material	Melting point in $^\circ\text{C}$	Boiling point in $^\circ\text{C}$
Alcohol	-98	65
Aluminium	660	2470
Copper	1077	2567
Lead	328	1737
Iron	1537	2737
Water	-	100

Specific latent heat of vaporisation of materials

Material	Specific latent heat of vaporisation in J kg^{-1}
Alcohol	11.2×10^5
Carbon dioxide	3.77×10^5
Glycerol	8.30×10^5
Turpentine	2.90×10^5
Water	22.6×10^5

Radiation weighting factors

Type of radiation	Radiation weighting factor
alpha	20
beta	1
fast neutrons	10
gamma	1
slow neutrons	3
X-rays	1

SECTION 1 — 25 marks

Attempt ALL questions

1. Which row in the table shows both quantities classified correctly?

	Scalar	Vector
A	weight	force
B	distance	velocity
C	mass	distance
D	force	mass
E	velocity	time

2. The graph shows how the velocity v of an object varies with time t .

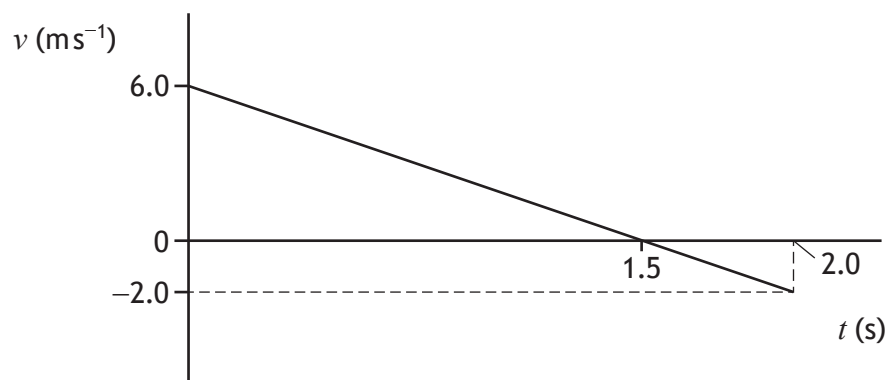

The displacement of the object at 2.0 seconds is

- A 4.0 m
- B 5.0 m
- C 6.0 m
- D 8.0 m
- E 10.0 m.

[Turn over

3. A car is travelling along a straight level road.
The car slows down at a constant rate of 2.0 m s^{-2} for a time of 8.0 s .
The final speed of the car is 5.0 m s^{-1} .
The initial speed of the car is

- A 7.0 m s^{-1}
- B 11 m s^{-1}
- C 16 m s^{-1}
- D 21 m s^{-1}
- E 80 m s^{-1} .

4. A cup rests on a table that rests on the Earth. The cup exerts a downward force on the table.



Which of the following is the reaction to this force?

- A The force of the table on the cup
 - B The force of the cup on the Earth
 - C The force of the Earth on the cup
 - D The force of the cup on the table
 - E The force of the table on the Earth
5. A crate of mass 180 kg is lifted through a height of 3.0 m in 2.5 s .
The minimum work done in lifting the crate through this height is
- A 60 J
 - B 540 J
 - C 1800 J
 - D 2200 J
 - E 5300 J .

6. An asteroid of mass 25 kg is travelling at a speed of 9200 m s^{-1} .
On entering the Earth's atmosphere, the asteroid burns up completely.
The maximum amount of heat energy released is

- A $1.2 \times 10^5 \text{ J}$
- B $2.3 \times 10^5 \text{ J}$
- C $2.9 \times 10^6 \text{ J}$
- D $1.1 \times 10^9 \text{ J}$
- E $2.1 \times 10^9 \text{ J}$.

7. The speed v of a satellite in orbit around the Earth is given by the relationship

$$v = \sqrt{rg}$$

where: r is the total distance from the centre of the Earth to the satellite in m
 g is the gravitational field strength at the location of the satellite in N kg^{-1} .

The radius of the Earth is $6.4 \times 10^6 \text{ m}$.

The height of a satellite above the surface of the Earth is $3.6 \times 10^7 \text{ m}$.

The gravitational field strength at this height is 0.22 N kg^{-1} .

The speed of the satellite is

- A 1200 m s^{-1}
- B 2800 m s^{-1}
- C 3100 m s^{-1}
- D 7900 m s^{-1}
- E $20\,000 \text{ m s}^{-1}$.

[Turn over

8. The weight of an astronaut on Earth is 710 N.

The weight of the astronaut on Mars is

- A 72 N
- B 190 N
- C 270 N
- D 710 N
- E 2600 N.

9. Sirius is the brightest star in the night sky.

The distance from Earth to Sirius is 8.6 light-years.

This distance is equivalent to

- A 2.7×10^8 m
- B 2.3×10^{13} m
- C 1.4×10^{15} m
- D 9.5×10^{15} m
- E 8.1×10^{16} m.

10. The line spectrum from a star is shown, along with the line spectra of the elements hydrogen, helium, carbon, and nitrogen.

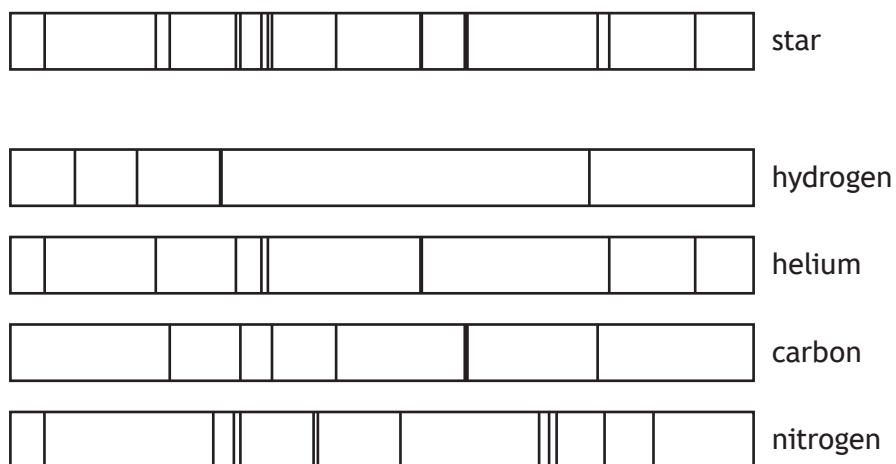

The elements present in this star are

- A hydrogen and helium
- B hydrogen and carbon
- C helium and carbon
- D helium and nitrogen
- E carbon and nitrogen.

[Turn over

11. A technician uses an oscilloscope to test three different power supplies.
The diagrams represent the traces seen on the screen of the oscilloscope.

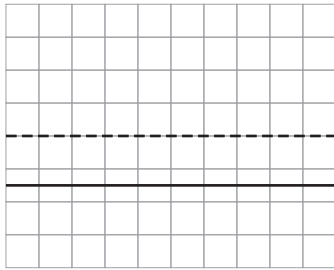

trace X

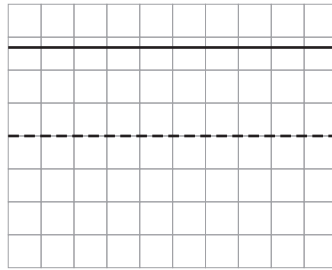

trace Y

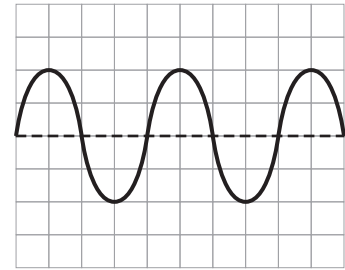

trace Z

Which row in the table identifies trace X, trace Y, and trace Z?

	trace X	trace Y	trace Z
A	d.c.	d.c.	d.c.
B	a.c.	d.c.	d.c.
C	a.c.	a.c.	d.c.
D	a.c.	a.c.	a.c.
E	d.c.	d.c.	a.c.

12. An electric field exists around two point charges Q and R.
 The diagram shows the path taken by a charged particle as it travels through the field.
 The motion of the particle is as shown.



Which row in the table identifies the charge on the particle, the charge on Q, and the charge on R?

	Charge on particle	Charge on Q	Charge on R
A	positive	negative	negative
B	negative	negative	positive
C	negative	positive	negative
D	positive	negative	positive
E	positive	positive	positive

[Turn over

13. A circuit is set up as shown.

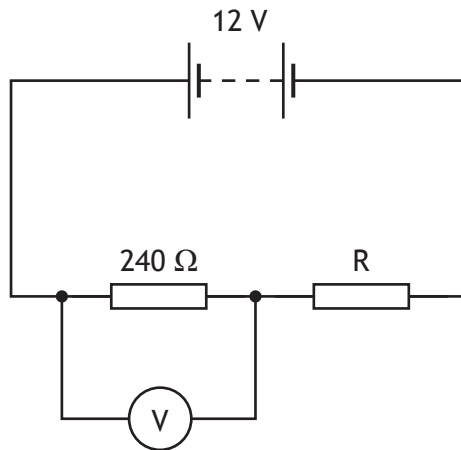

The reading on the voltmeter is 3.0 V.

The resistance of resistor R is

- A 20 Ω
- B 80 Ω
- C 320 Ω
- D 720 Ω
- E 960 Ω.

14. Three resistors are connected as shown.

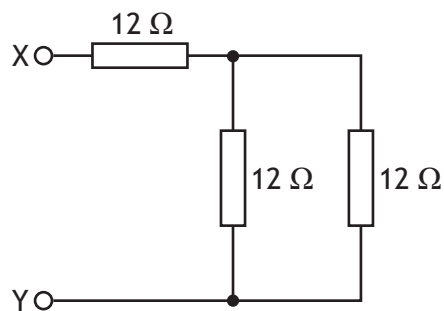

The total resistance between X and Y is

- A 4 Ω
- B 6 Ω
- C 8 Ω
- D 18 Ω
- E 36 Ω.

15. A circuit is set up as shown.

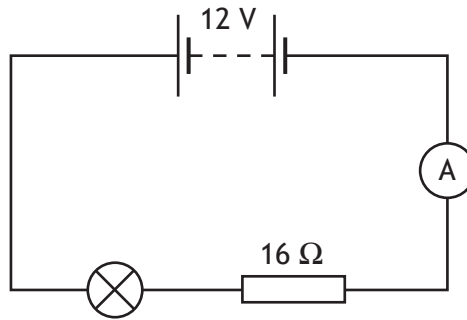

The reading on the ammeter is 0.50 A.

The resistance of the lamp is 8.0 Ω .

The power dissipated in the lamp is

- A 2.0 W
- B 4.0 W
- C 6.0 W
- D 9.0 W
- E 18 W.

[Turn over

16. A kettle, a television, and a microwave are connected to the mains supply.

The kettle has a power rating of 2.6 kW.

The television has a power rating of 170 W.

The microwave has a power rating of 900 W.

Which row in the table shows the appropriate fuse rating for the kettle, the television, and the microwave?

	Appropriate fuse rating for kettle (A)	Appropriate fuse rating for television (A)	Appropriate fuse rating for microwave (A)
A	3	13	3
B	13	3	13
C	13	13	3
D	3	3	13
E	13	3	3

17. A group of students sets up the experiment shown to determine a value for the specific heat capacity of water.

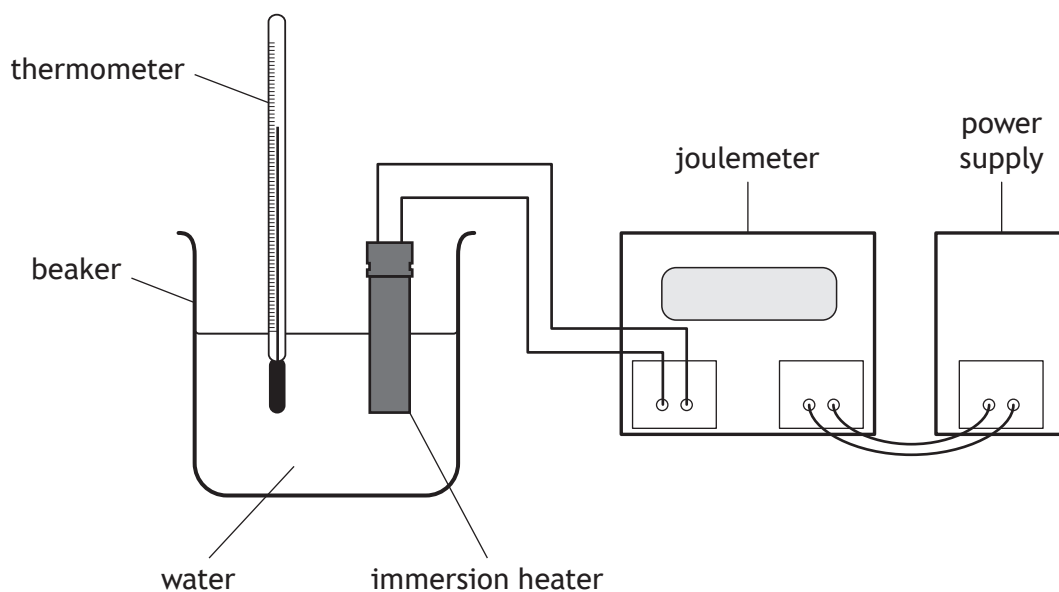

The students make the following statements about how the experimental procedure could be improved.

- I Insulate the beaker to reduce heat lost to the surroundings.
- II Move the immersion heater further into the water.
- III Use a stopwatch to measure the time for which the water is heated.

Which of these statements is/are correct?

- A I only
- B II only
- C I and II only
- D I and III only
- E I, II and III

[Turn over

18. A hot substance is cooled.

The graph shows how the temperature of the substance changes with time.

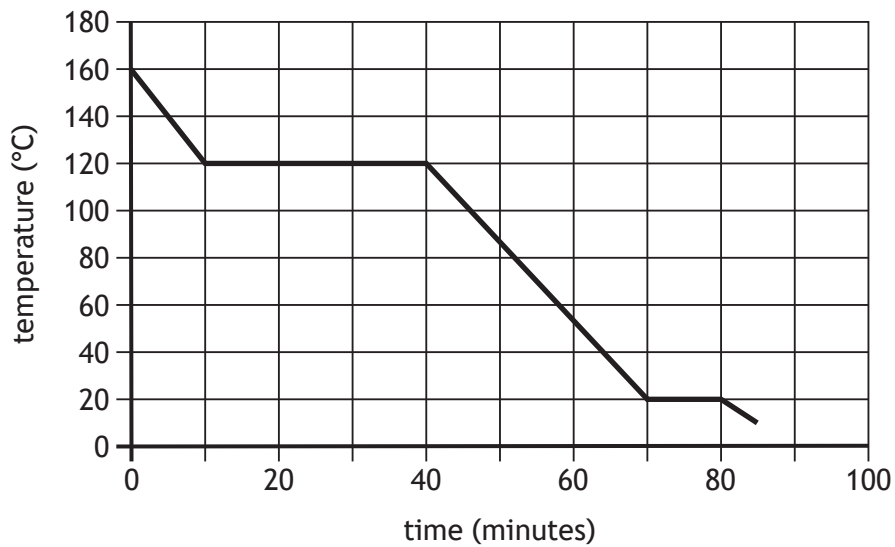

A student makes the following statements about the substance.

- I The boiling point of the substance is 120 °C.
- II At a time of 40 minutes, the substance is a gas.
- III The melting point of the substance is 20 °C.

Which of these statements is/are correct?

- A I only
- B II only
- C I and III only
- D II and III only
- E I, II and III

19. A ballet dancer wears shoes that have a flat section on the front called a platform.
When the ballet dancer stands on the tips of their toes, the platform on each shoe is flat on the floor.

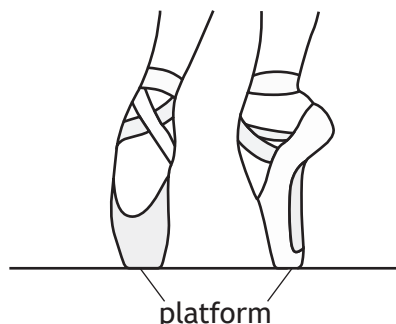

The area of the platform on each shoe is $1.6 \times 10^{-3} \text{ m}^2$.
The weight of the ballet dancer is 520 N.
The pressure exerted on the floor by the ballet dancer is

- A $3.1 \times 10^{-6} \text{ Pa}$
 - B $6.2 \times 10^{-6} \text{ Pa}$
 - C $8.3 \times 10^{-1} \text{ Pa}$
 - D $1.6 \times 10^5 \text{ Pa}$
 - E $3.3 \times 10^5 \text{ Pa}$.
20. A tennis ball contains a fixed mass of air at a temperature of $20.0 \text{ }^\circ\text{C}$.
The pressure of the air inside the ball is $1.90 \times 10^5 \text{ Pa}$.
During a tennis match the temperature of the air inside the ball rises to $35.0 \text{ }^\circ\text{C}$.
The volume of the air remains constant.
The pressure of the air inside the ball is now
- A $1.09 \times 10^5 \text{ Pa}$
 - B $1.81 \times 10^5 \text{ Pa}$
 - C $1.87 \times 10^5 \text{ Pa}$
 - D $2.00 \times 10^5 \text{ Pa}$
 - E $3.33 \times 10^5 \text{ Pa}$.

[Turn over

21. The diagram represents a wave.

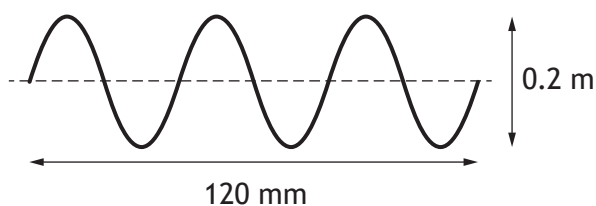

Which row in the table shows the wavelength and amplitude of the wave?

	Wavelength (mm)	Amplitude (m)
A	20	0.1
B	40	0.1
C	40	0.2
D	120	0.1
E	120	0.2

22. A teacher gives a group of students two clues to identify a particular band of the electromagnetic spectrum.

Clue 1: Diffracts around obstacles more than visible light.

Clue 2: Has a greater frequency than microwave radiation.

The band of the electromagnetic spectrum these clues refer to is

- A gamma rays
- B infrared
- C ultraviolet
- D radio
- E X-rays.

23. A radioactive source has an average activity of 5.2 MBq over a time of 1.2 hours.
The number of nuclear disintegrations that occur in the source in this time is
- A 1.2×10^3
 - B 4.3×10^6
 - C 6.2×10^6
 - D 3.7×10^8
 - E 2.2×10^{10} .
24. A sample of tissue is exposed to a source of alpha particles.
The equivalent dose received from this source during a time of 5 minutes is 480 μSv .
The equivalent dose rate is
- A $1.6 \mu\text{Sv s}^{-1}$
 - B $96 \mu\text{Sv s}^{-1}$
 - C $2400 \mu\text{Sv s}^{-1}$
 - D $9600 \mu\text{Sv s}^{-1}$
 - E $144\,000 \mu\text{Sv s}^{-1}$.
25. Energy is released when two small nuclei combine during a nuclear reaction to form a larger nucleus.
This is a description of
- A nuclear fission
 - B nuclear fusion
 - C alpha decay
 - D beta decay
 - E gamma emission.

[END OF SECTION 1. NOW ATTEMPT THE QUESTIONS IN SECTION 2 OF
YOUR QUESTION AND ANSWER BOOKLET]

[BLANK PAGE]

DO NOT WRITE ON THIS PAGE

[BLANK PAGE]

DO NOT WRITE ON THIS PAGE

[BLANK PAGE]

DO NOT WRITE ON THIS PAGE

FOR OFFICIAL USE



National
Qualifications
2025

Mark

X857/75/01

**Physics
Section 1 — Answer grid
and Section 2**

THURSDAY, 15 MAY

1:00 PM – 3:30 PM



* X 8 5 7 7 5 0 1 *

Fill in these boxes and read what is printed below.

Full name of centre

Town

Forename(s)

Surname

Number of seat

Date of birth

Day

Month

Year

Scottish candidate number

Total marks — 135

SECTION 1 — 25 marks

Attempt ALL questions.

Instructions for completion of Section 1 are given on *page 02*.

SECTION 2 — 110 marks

Attempt ALL questions.

Reference may be made to the data sheet on *page 02* of the question paper X857/75/02 and to the relationships sheet X857/75/11.

Write your answers clearly in the spaces provided in this booklet. Additional space for answers and rough work is provided at the end of this booklet. If you use this space you must clearly identify the question number you are attempting. Any rough work must be written in this booklet. Score through your rough work when you have written your final copy.

Use **blue** or **black** ink.

Before leaving the examination room you must give this booklet to the Invigilator; if you do not, you may lose all the marks for this paper.



* X 8 5 7 7 5 0 1 0 1 *

SECTION 1 — 25 marks

The questions for Section 1 are contained in the question paper X857/75/02.
Read these and record your answers on the answer grid on *page 03* opposite.
Use **blue** or **black** ink. Do NOT use gel pens or pencil.

1. The answer to each question is **either** A, B, C, D or E. Decide what your answer is, then fill in the appropriate bubble (see sample question below).
2. There is **only one correct** answer to each question.
3. Any rough work must be written in the additional space for answers and rough work at the end of this booklet.

Sample question

The energy unit measured by the electricity meter in your home is the

- A ampere
- B kilowatt-hour
- C watt
- D coulomb
- E volt.

The correct answer is **B** — kilowatt-hour. The answer **B** bubble has been clearly filled in (see below).

A	B	C	D	E
<input type="radio"/>	<input checked="" type="radio"/>	<input type="radio"/>	<input type="radio"/>	<input type="radio"/>

Changing an answer

If you decide to change your answer, cancel your first answer by putting a cross through it (see below) and fill in the answer you want. The answer below has been changed to **D**.

A	B	C	D	E
<input type="radio"/>	<input checked="" type="radio"/>	<input type="radio"/>	<input checked="" type="radio"/>	<input type="radio"/>

If you then decide to change back to an answer you have already scored out, put a tick (✓) to the **right** of the answer you want, as shown below:

A	B	C	D	E	or	A	B	C	D	E
<input type="radio"/>	<input checked="" type="radio"/>	<input type="radio"/>	<input checked="" type="radio"/>	<input type="radio"/>		<input type="radio"/>	<input checked="" type="radio"/>	<input type="radio"/>	<input type="radio"/>	<input type="radio"/>



SECTION 1 — Answer grid



	A	B	C	D	E
1	<input type="radio"/>	<input type="radio"/>	<input type="radio"/>	<input type="radio"/>	<input type="radio"/>
2	<input type="radio"/>	<input type="radio"/>	<input type="radio"/>	<input type="radio"/>	<input type="radio"/>
3	<input type="radio"/>	<input type="radio"/>	<input type="radio"/>	<input type="radio"/>	<input type="radio"/>
4	<input type="radio"/>	<input type="radio"/>	<input type="radio"/>	<input type="radio"/>	<input type="radio"/>
5	<input type="radio"/>	<input type="radio"/>	<input type="radio"/>	<input type="radio"/>	<input type="radio"/>
6	<input type="radio"/>	<input type="radio"/>	<input type="radio"/>	<input type="radio"/>	<input type="radio"/>
7	<input type="radio"/>	<input type="radio"/>	<input type="radio"/>	<input type="radio"/>	<input type="radio"/>
8	<input type="radio"/>	<input type="radio"/>	<input type="radio"/>	<input type="radio"/>	<input type="radio"/>
9	<input type="radio"/>	<input type="radio"/>	<input type="radio"/>	<input type="radio"/>	<input type="radio"/>
10	<input type="radio"/>	<input type="radio"/>	<input type="radio"/>	<input type="radio"/>	<input type="radio"/>
11	<input type="radio"/>	<input type="radio"/>	<input type="radio"/>	<input type="radio"/>	<input type="radio"/>
12	<input type="radio"/>	<input type="radio"/>	<input type="radio"/>	<input type="radio"/>	<input type="radio"/>
13	<input type="radio"/>	<input type="radio"/>	<input type="radio"/>	<input type="radio"/>	<input type="radio"/>
14	<input type="radio"/>	<input type="radio"/>	<input type="radio"/>	<input type="radio"/>	<input type="radio"/>
15	<input type="radio"/>	<input type="radio"/>	<input type="radio"/>	<input type="radio"/>	<input type="radio"/>
16	<input type="radio"/>	<input type="radio"/>	<input type="radio"/>	<input type="radio"/>	<input type="radio"/>
17	<input type="radio"/>	<input type="radio"/>	<input type="radio"/>	<input type="radio"/>	<input type="radio"/>
18	<input type="radio"/>	<input type="radio"/>	<input type="radio"/>	<input type="radio"/>	<input type="radio"/>
19	<input type="radio"/>	<input type="radio"/>	<input type="radio"/>	<input type="radio"/>	<input type="radio"/>
20	<input type="radio"/>	<input type="radio"/>	<input type="radio"/>	<input type="radio"/>	<input type="radio"/>
21	<input type="radio"/>	<input type="radio"/>	<input type="radio"/>	<input type="radio"/>	<input type="radio"/>
22	<input type="radio"/>	<input type="radio"/>	<input type="radio"/>	<input type="radio"/>	<input type="radio"/>
23	<input type="radio"/>	<input type="radio"/>	<input type="radio"/>	<input type="radio"/>	<input type="radio"/>
24	<input type="radio"/>	<input type="radio"/>	<input type="radio"/>	<input type="radio"/>	<input type="radio"/>
25	<input type="radio"/>	<input type="radio"/>	<input type="radio"/>	<input type="radio"/>	<input type="radio"/>



[BLANK PAGE]

DO NOT WRITE ON THIS PAGE



[Turn over for SECTION 2

DO NOT WRITE ON THIS PAGE



* X 8 5 7 7 5 0 1 0 5 *

SECTION 2 — 110 marks

Attempt ALL questions

1. A gardener is mowing grass with a lawnmower.

The gardener walks from point X to point Y as shown, while pushing the lawnmower.

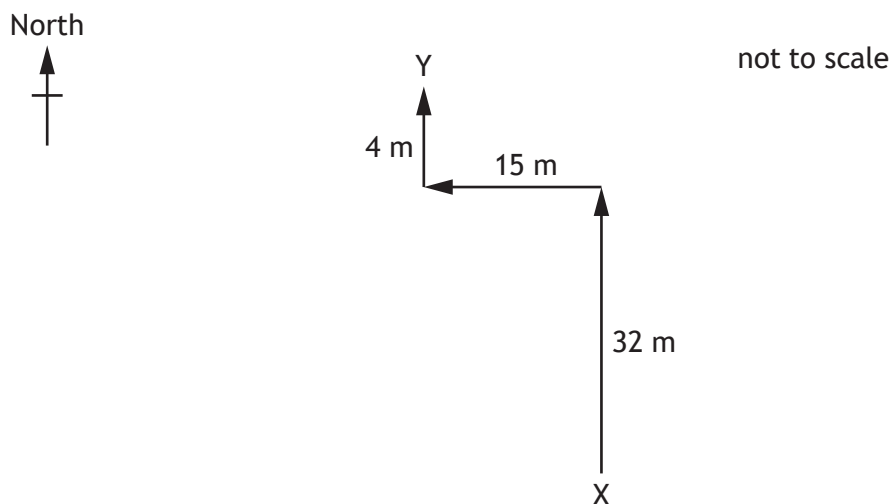

- (a) (i) By scale diagram or otherwise, determine the magnitude of the resultant displacement of the gardener from point X to point Y.

2

Space for working and answer



1. (a) (continued)

MARKS DO NOT WRITE IN THIS MARGIN

- (ii) By scale diagram or otherwise, determine the direction of the resultant displacement of the gardener from point X to point Y.

2

Space for working and answer

- (b) The gardener takes 55 s to walk from point X to point Y.

Determine the average velocity of the gardener from point X to point Y.

3

Space for working and answer

- (c) The gardener pushes the lawnmower with an average force of 68 N while walking between point X and point Y.

Calculate the work done in moving the lawnmower between point X and point Y.

3

Space for working and answer

[Turn over



* X 8 5 7 7 5 0 1 0 7 *

2. The Falcon Heavy rocket is used to carry a satellite from Earth into space.

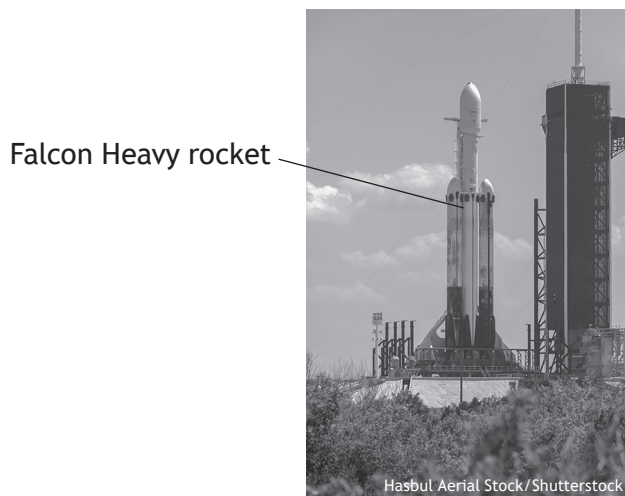

(a) (i) The total mass of the rocket and satellite at launch is 1.43×10^6 kg.
 Calculate the weight of the rocket and satellite at launch. 3
Space for working and answer

(ii) At launch, the initial upward thrust acting on the rocket is 2.28×10^7 N.
 Determine the initial acceleration of the rocket and satellite. 4
Space for working and answer



2. (continued)

- (b) The rocket is designed so that many parts are reusable. Two reusable parts are the payload fairing sections, which protect the satellite during launch.

Once the rocket reaches space, the payload fairing sections are detached and re-enter the Earth's atmosphere.

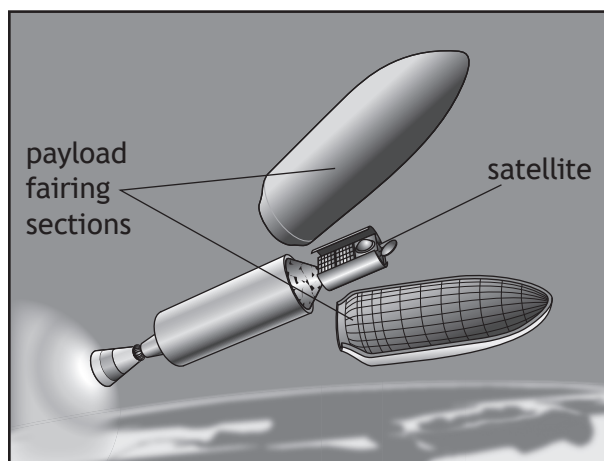

- (i) On the diagram below, show all the forces acting on one of the payload fairing sections as it falls vertically through the Earth's atmosphere.

You must name these forces and show their directions.

2

(An additional diagram, if required, can be found on page 46.)



[Turn over



2. (b) (continued)

- (ii) At one point, as it falls through the atmosphere, a parachute attached to the payload fairing section is opened. This causes the speed of the payload fairing section to decrease rapidly.

Explain, in terms of forces, how the parachute reduces the speed of the payload fairing section.

2

- (iii) The graph shows how the vertical velocity v_v of one of the payload fairing sections varies with time t from the moment the parachute is opened.

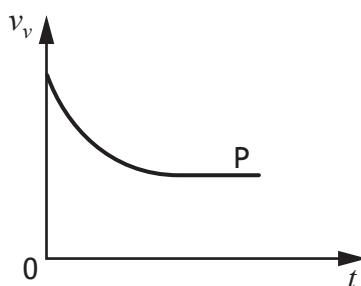

The weight of the payload fairing section is 9300 N.

State the magnitude of the total upward force acting on the payload fairing section at point P.

You must justify your answer.

2



[Turn over for next question

DO NOT WRITE ON THIS PAGE



* X 8 5 7 7 5 0 1 1 1 *

3. Ski jumping is a winter sport in which competitors aim to achieve the longest jump after sliding down a specially designed curved ramp.



During the jump, ski jumpers adopt the position shown below.



The length of the jump is measured from the end of the ramp to where the ski jumper lands.

Using your knowledge of physics, comment on factors that affect the length of a jump made by a ski jumper.

3



3. (continued)

[Turn over



* X 8 5 7 7 5 0 1 1 3 *

4. In 2023, a spacecraft was launched from Earth to investigate the asteroid Psyche. Psyche is located in the asteroid belt, between Mars and Jupiter. The spacecraft will reach Psyche in 2029.

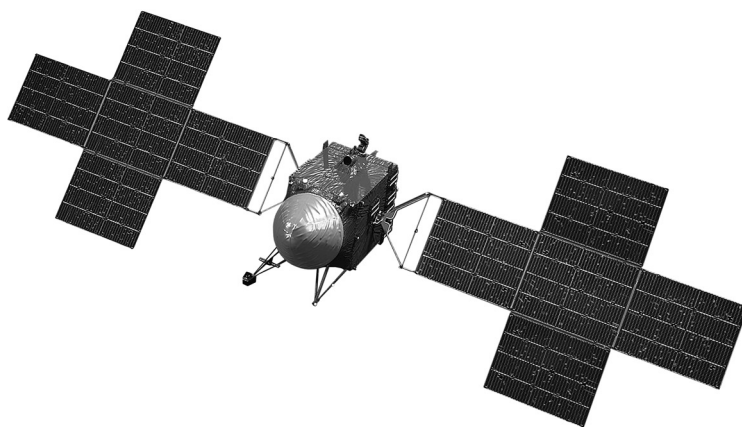

- (a) On its journey to Psyche the spacecraft will pass close by the planet Mars. Explain how passing close to Mars will reduce the journey time to Psyche. 2
- (b) On its journey, the spacecraft uses an ion drive engine to provide thrust. The ion drive engine produces a small unbalanced force on the spacecraft.
- (i) Explain how this small unbalanced force can still result in a large increase in speed, even though the spacecraft has a large mass. 1



4. (b) (continued)

(ii) The ion drive engine is powered by solar cells. Near the Earth the solar cells provide 20 kW of electrical power. As the spacecraft approaches Psyche, the solar cells will only produce 2.3 kW of electrical power.

Explain why the solar cells produce less power as the spacecraft approaches Psyche.

1

(c) When the spacecraft reaches its destination, it will go into orbit around Psyche.

(i) Initially, the spacecraft will complete 41 orbits of Psyche in 56 days.

Determine the orbital period of the spacecraft.

1

Space for working and answer

(ii) After 56 days the spacecraft will move to an orbit closer to Psyche.

State the effect this change will have on the orbital period of the spacecraft.

1

[Turn over



* X 8 5 7 7 5 0 1 1 5 *

5. A Van de Graaff generator is a device that is used to generate an electric charge on a hollow metal dome.

- (a) During a classroom demonstration a teacher places some small aluminium foil dishes on top of the dome.

When the Van de Graaff generator is switched on, the metal dome becomes positively charged.

The foil dishes are observed to 'fly away' from the metal dome as shown.

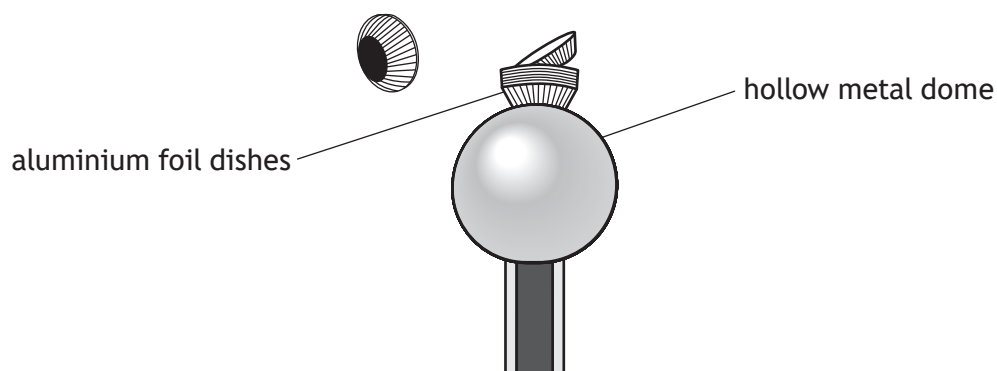

Explain why the foil dishes are repelled from the metal dome.

1



* X 8 5 7 7 5 0 1 1 6 *

5. (continued)

- (b) The teacher then discharges the dome by placing a small metal sphere near the dome, as shown.

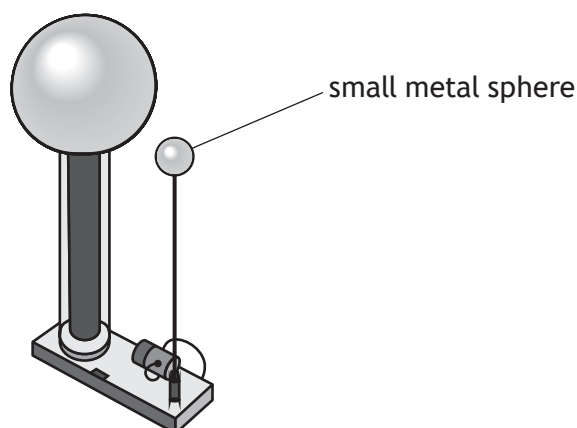

During the discharge, 2.50×10^{-6} C of charge is transferred to the dome in 0.80 ms.

- (i) Calculate the average current during the discharge.

3

Space for working and answer

- (ii) The magnitude of the charge on an electron is 1.60×10^{-19} C.

Determine the number of electrons transferred during the discharge process.

1

Space for working and answer

[Turn over



6. A student carries out an investigation to determine the resistance of a resistor R. The student is provided with the following components:

resistor R, 6.0 V battery, variable resistor, ammeter, voltmeter, connecting leads

- (a) Complete the circuit diagram to show how these components are connected to allow the student to measure the current in and voltage across resistor R, for a range of different voltages across resistor R.

2

(An additional diagram, if required, can be found on *page 46*.)

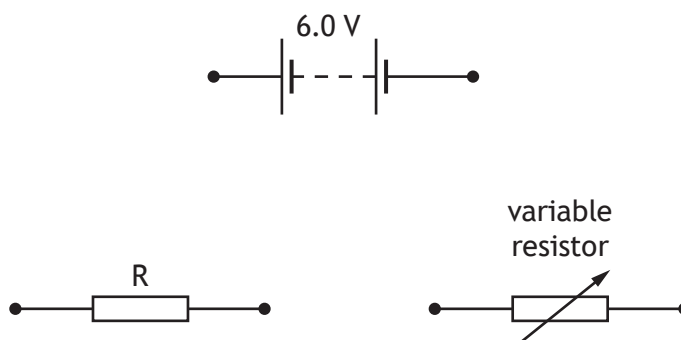

6. (continued)

- (b) The student obtains a range of readings for the current in and the voltage across resistor R.

The student uses these readings to draw the following graph.

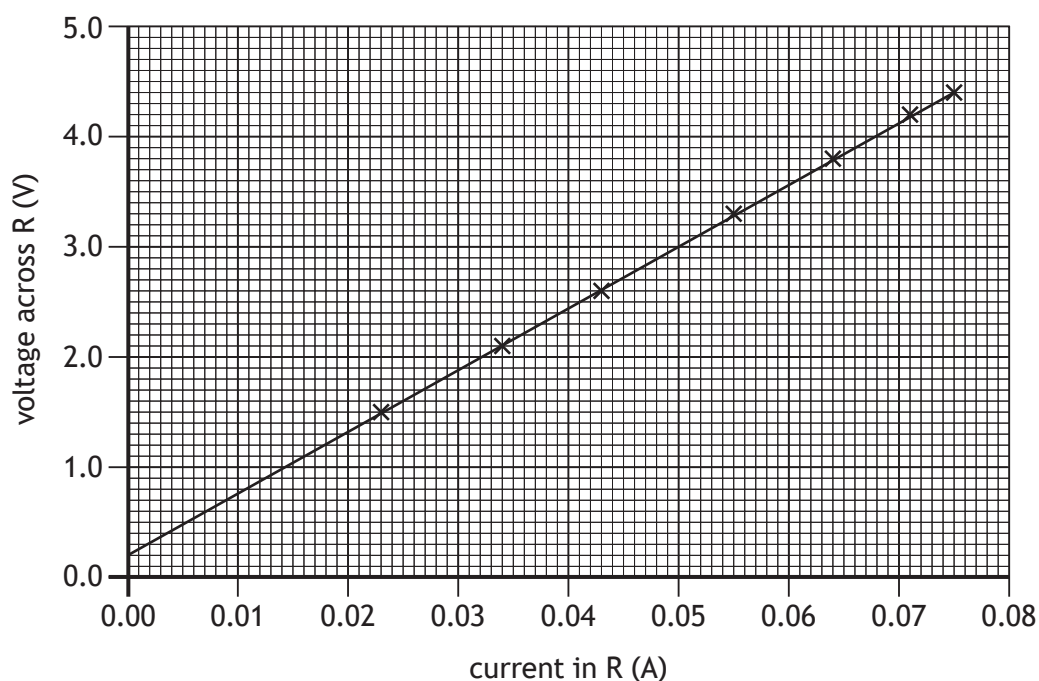

Using the gradient of the graph, determine the resistance of resistor R.

2

Space for working and answer

[Turn over



* X 8 5 7 7 5 0 1 1 9 *

6. (continued)

- (c) The student now replaces resistor R with a filament lamp and repeats the investigation. A sketch graph of the student's results is shown.

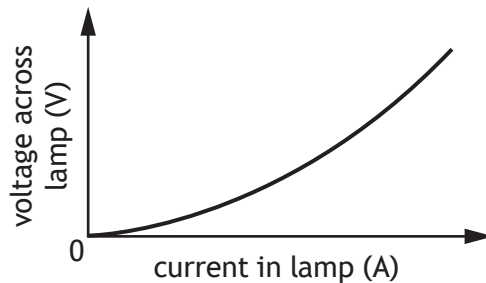

State a conclusion that can be made about the resistance of the filament lamp. 1



[Turn over for next question

DO NOT WRITE ON THIS PAGE



* X 8 5 7 7 5 0 1 2 1 *

7. At night a path is illuminated by a set of four LED spotlights.



Each spotlight consists of an LED and a resistor connected in series. The circuit diagram shows how the four spotlights are connected.

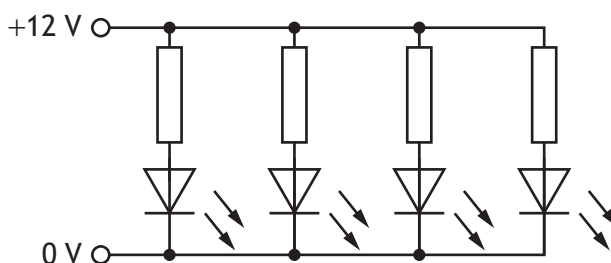

(a) Describe one advantage of connecting the spotlights as shown in the circuit diagram.

1

(b) Each spotlight has a power rating of 4.8 W.

Determine the total current drawn from the power supply when all four spotlights are operating correctly.

3

Space for working and answer



7. (continued)

- (c) The spotlight circuit is connected to the circuit shown below, so that the spotlights switch on automatically when it gets dark.

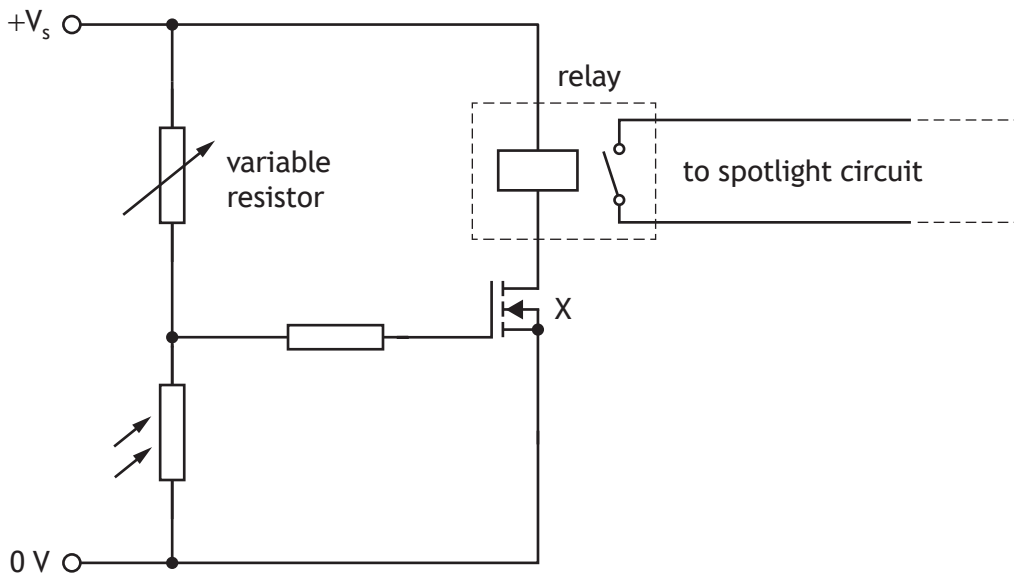

- (i) State the name of component X. 1
- (ii) Explain how the circuit operates to activate the relay when it gets dark. 3

[Turn over



8. A student is describing how the following circuit works.

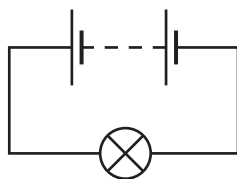

The student states:

'When I connect the battery to the lamp, electrons are fired out from the battery and whizz round the circuit. The electrons are changed into light by the lamp. If I add another lamp to the circuit the lamps will be dimmer.'

Using your knowledge of physics, comment on the statement made by the student. 3



8. (continued)

[Turn over



* X 8 5 7 7 5 0 1 2 5 *

9. An ice making machine is an appliance used for making ice cubes.

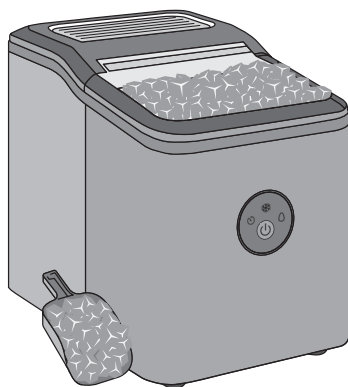

The ice making machine operates by first cooling water to 0 °C. The water is then frozen to form ice cubes. Once formed, the ice cubes are released into a collecting tray.

(a) The ice making machine is initially filled with 0.38 kg of water at a temperature of 22 °C.

(i) Calculate the amount of energy removed from the water to reduce the temperature of the water to 0 °C.

3

Space for working and answer

(ii) The ice making machine has a power rating of 120 W.

Calculate the minimum amount of time it takes to reduce the temperature of the water to 0 °C.

3

Space for working and answer



9. (a) (continued)

(iii) In practice, the time taken to reduce the temperature of the water to 0 °C is much greater than calculated in (a) (ii), due to heat gained from the surroundings.

Suggest one way the manufacturer could improve the ice making machine to overcome this problem.

1

(b) Once the water is at 0 °C, a further 15.3 kJ of energy is removed from the water to form ice cubes.

Calculate the maximum mass of ice cubes produced in this process.

3

Space for working and answer

[Turn over



10. A student sets up the apparatus shown to investigate how the volume of a fixed mass of air is related to its pressure, when temperature is kept constant.

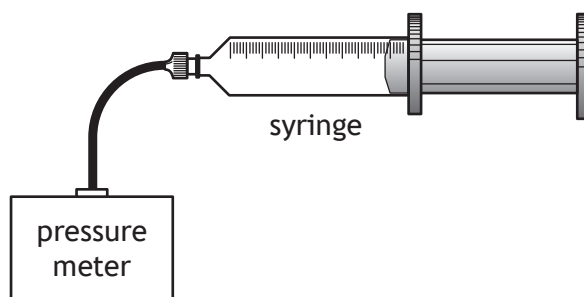

The student varies the volume of the air in the syringe and measures the pressure of the air in the syringe with the pressure meter.

- (a) Describe how the kinetic model accounts for the pressure of the air in the syringe.

1

- (b) For each volume of air in the syringe the student calculates the value of $\frac{1}{\text{volume}}$.

The results of the experiment are shown in the table.

$\frac{1}{\text{volume}}$ (ml^{-1})	Pressure (kPa)
0.05	32
0.10	67
0.13	81
0.17	112
0.25	160



10. (b) (continued)

(i) Using the graph paper, draw a graph of these results.

(Additional graph paper, if required can be found on *page 47.*)

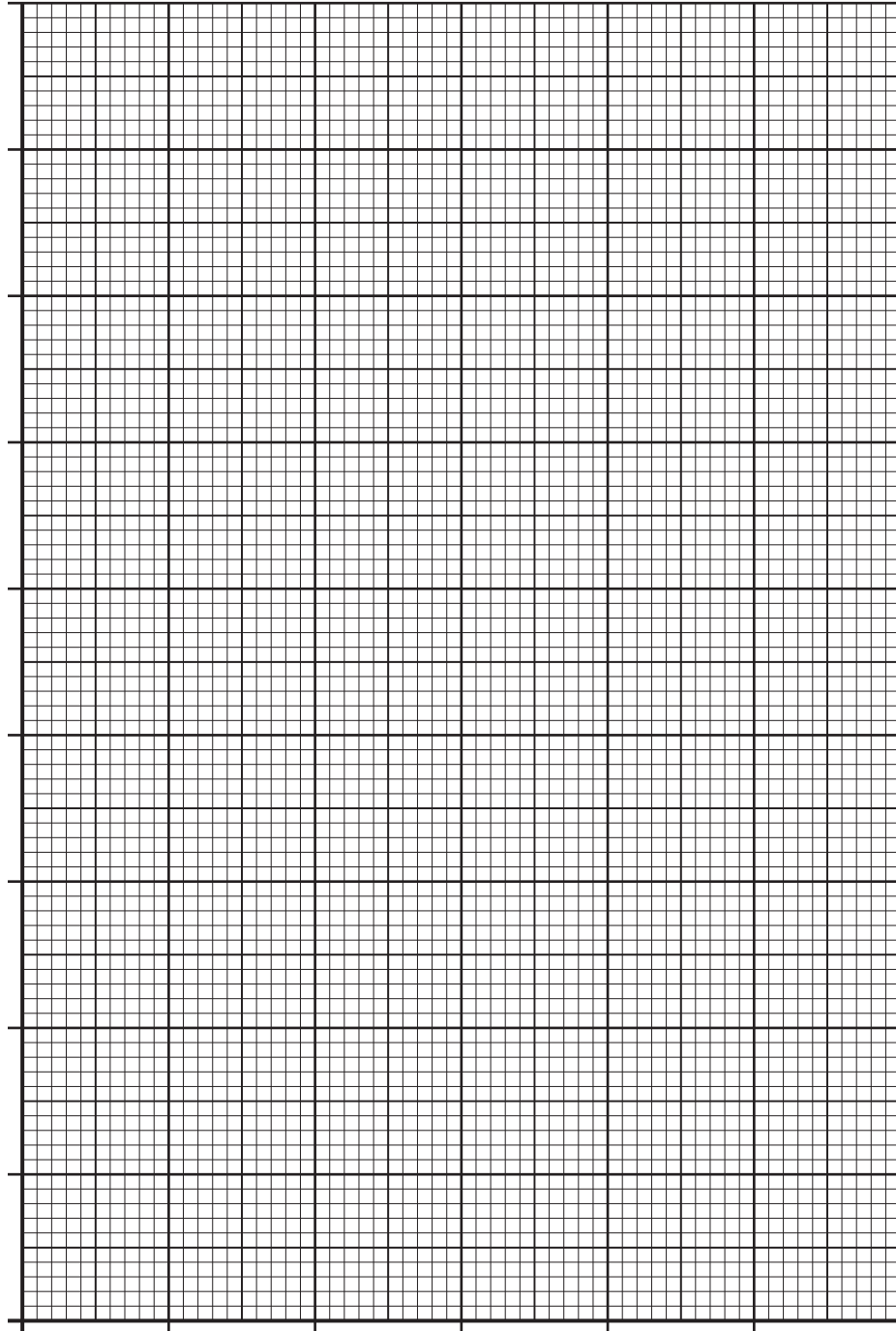

[Turn over



10. (b) (continued)

(ii) Using information from your graph, state a conclusion that can be made about the relationship between the volume of a fixed mass of air at constant temperature and its pressure.

1

(iii) Using your graph, determine the volume of trapped air in the syringe at a pressure of 148 kPa.

2

Space for working and answer

(c) Suggest one way in which the experimental procedure could be improved to give more reliable results.

1



* X 8 5 7 7 5 0 1 3 0 *

[Turn over for next question

DO NOT WRITE ON THIS PAGE



* X 8 5 7 7 5 0 1 3 1 *

11. Scotland's first wave park for watersports opened in Edinburgh in 2024.

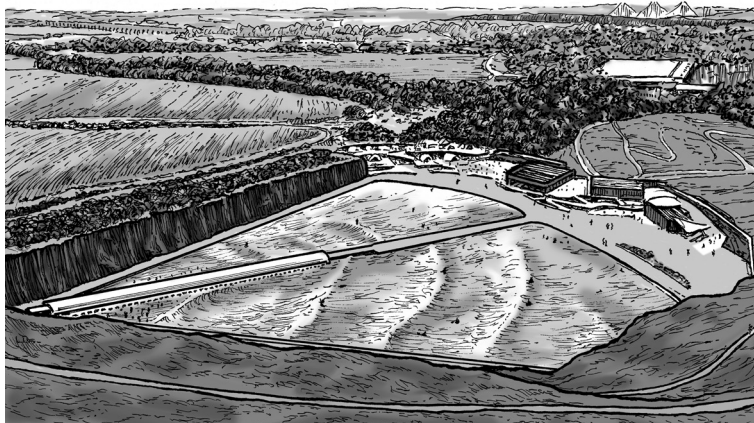

A wave generator produces water waves that travel along the length of a pool. The wave generator produces 500 waves in 30 minutes and the length of the pool is 160 m.

(a) Water waves are transverse waves.

State what is meant by the term *transverse wave*.

1

(b) (i) Show that the frequency of the waves is 0.28 Hz.

Space for working and answer

2



11. (b) (continued)

(ii) Each wave takes 32 s to travel the length of the pool.
Calculate the average speed of the waves.
Space for working and answer

3

(iii) Calculate the average wavelength of the waves.
Space for working and answer

3

[Turn over



12. Many golfers now use either a GPS device or an infrared laser rangefinder to measure the distance required for their next shot.

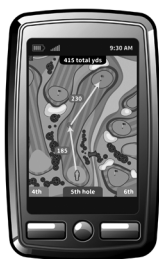

GPS device



infrared laser rangefinder

- (a) The GPS device receives microwave signals from satellites orbiting the Earth. The satellites orbit at an altitude of 20 200 km and with a period of 12 hours.

- (i) At one point in time a satellite is directly overhead.

Show that the time taken for a microwave signal to travel from the satellite to the GPS device is 0.067 s.

2

Space for working and answer

- (ii) State whether the GPS satellites are geostationary satellites. You must justify your answer.

2



* X 8 5 7 7 5 0 1 3 4 *

12. (continued)

(b) The laser rangefinder emits a beam of infrared radiation with a wavelength of 904 nm. The beam of infrared radiation is directed towards a distant object. The beam reflects from the object and is detected in the rangefinder.

(i) State a suitable detector for infrared radiation in the rangefinder.

1

(ii) Calculate the frequency of the infrared radiation emitted by the rangefinder.

3

Space for working and answer

(iii) A golfer aims the beam of infrared radiation towards a target.

The time taken between the infrared radiation being emitted and received by the rangefinder is 1.2×10^{-6} s.

Determine the distance of the target from the golfer.

4

Space for working and answer

[Turn over



* X 8 5 7 7 5 0 1 3 5 *

13. A student carries out an experiment to investigate the path of red light through a circular glass block.

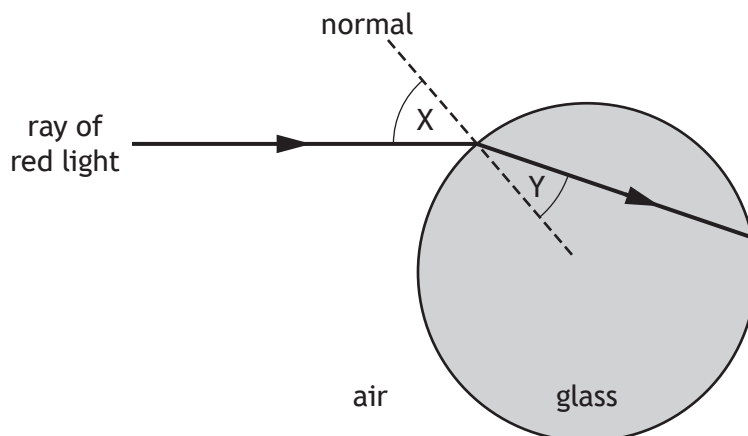

- (a) State the names given to angles X and Y. 1
- X:
- Y:
- (b) Explain why the ray of red light changes direction as it enters the circular glass block. 2



13. (continued)

(c) Complete the diagram below to show the path of the ray of red light after it exits the block.

(An additional diagram, if required, can be found on *page 48*.)

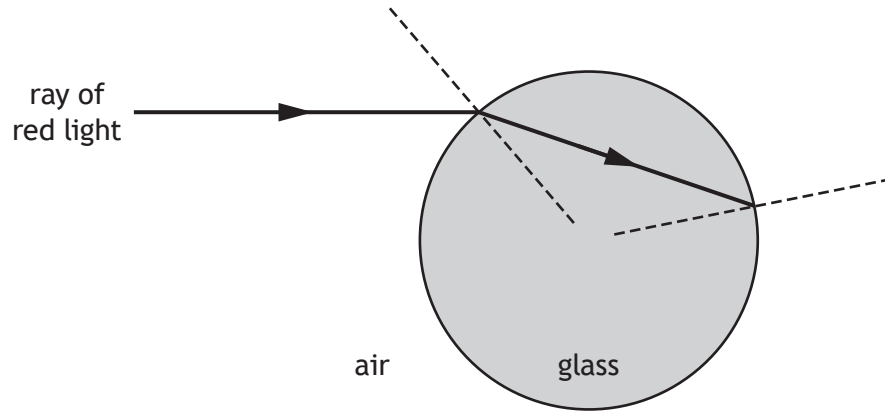

[Turn over



14. Leaks in underground wastewater pipes can be investigated using a radioactive material known as a tracer.
 A small quantity of the tracer is added to the water entering the pipe being investigated and the radiation emitted is monitored over a period of a few hours.

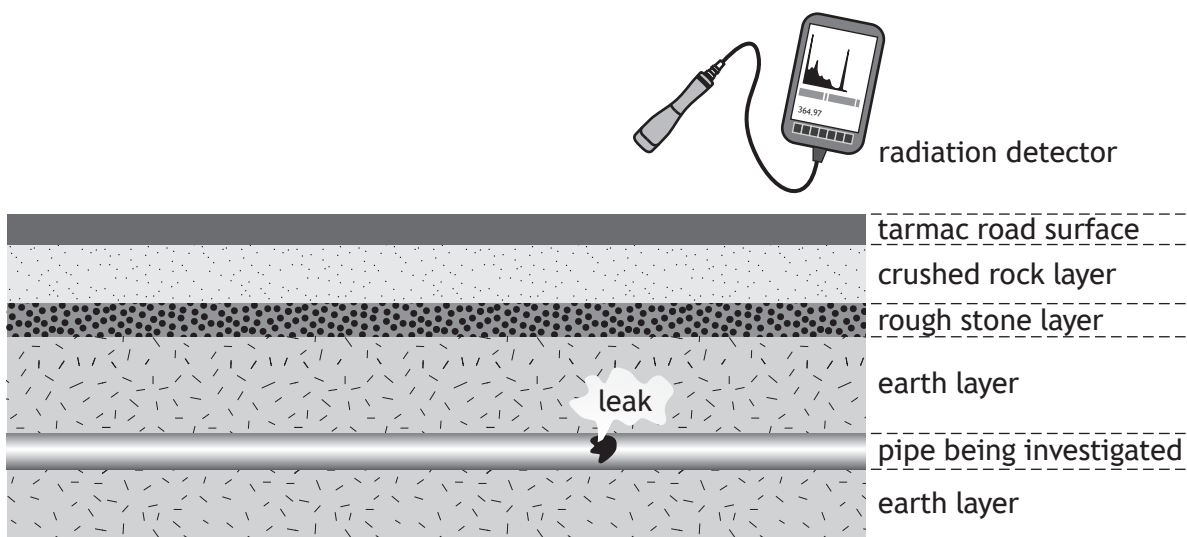

- (a) Explain why a tracer that emits gamma radiation is used for this investigation, rather than one that **only** emits alpha or beta radiation.

1

- (b) When selecting a tracer for this investigation, its half-life must also be considered.

- (i) State what is meant by the term *half-life*.

1



14. (b) (continued)

(ii) The following sources are available:

Radioactive source	Half-life	Radiation emitted
sodium-24	15 hours	beta and gamma
bismuth-204	11.2 hours	beta
barium-133	10.5 years	gamma
barium-137m	2.6 minutes	gamma

State which of these radioactive sources should be used for this investigation.

You must justify your answer.

2

[Turn over



14. (continued)

(c) The graph shows how the activity of a different source varies with time.

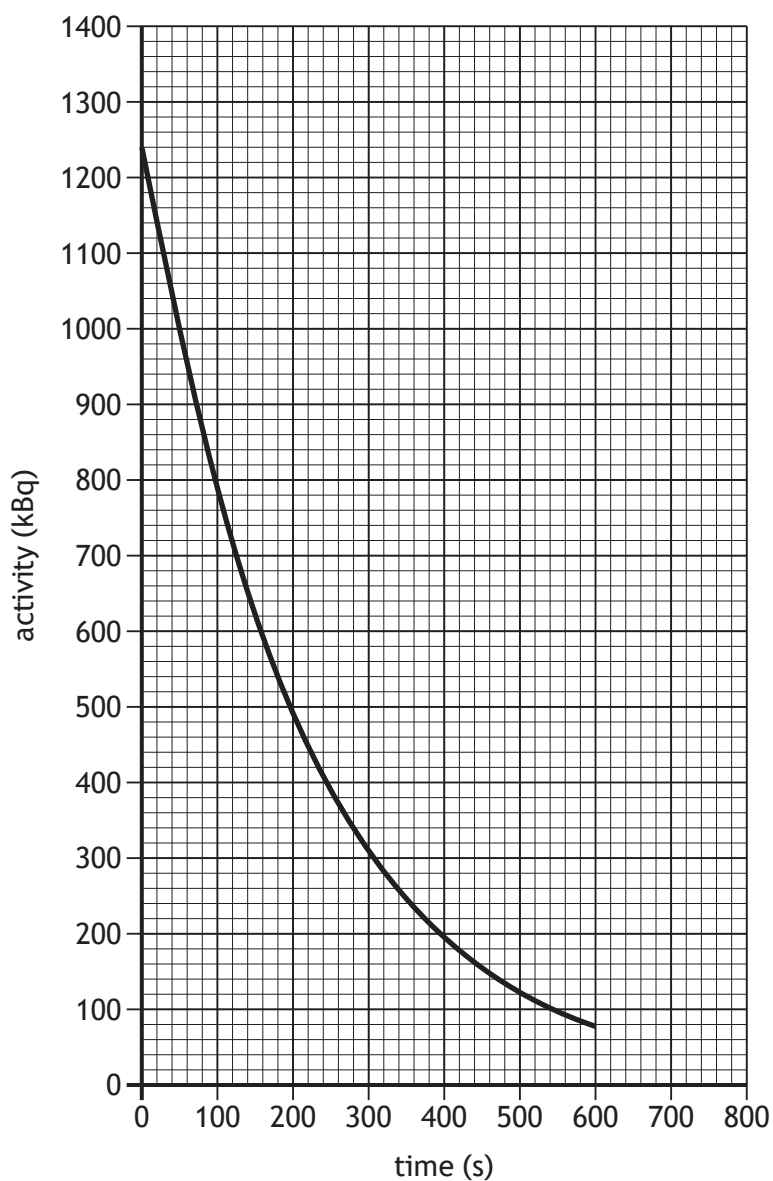

(i) Using information from the graph, determine the half-life of this radioactive source.

Space for working and answer

1



14. (c) (continued)

(ii) Predict the activity of the source at 700 s.

1

[Turn over



* X 8 5 7 7 5 0 1 4 1 *

15. A full-body scanner at an airport uses X-rays to check passengers for concealed items.

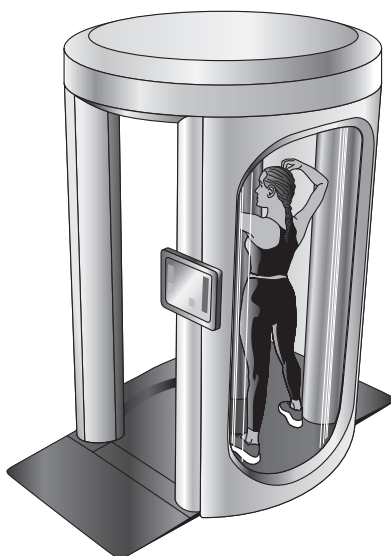

- (a) During a scan a passenger of mass 64 kg is exposed to X-rays.

The equivalent dose received by the passenger is $0.25 \mu\text{Sv}$.

- (i) Calculate the absorbed dose received by the passenger.

3

Space for working and answer

- (ii) Calculate the energy absorbed by the passenger.

3

Space for working and answer



15. (continued)

(b) X-rays cause ionisation.

State what is meant by the term *ionisation*.

1

(c) The scanner is operated by a member of airport staff.

Suggest one safety precaution the member of staff operating the scanner could take to minimise their exposure to the X-rays.

1

[END OF QUESTION PAPER]



* X 8 5 7 7 5 0 1 4 3 *

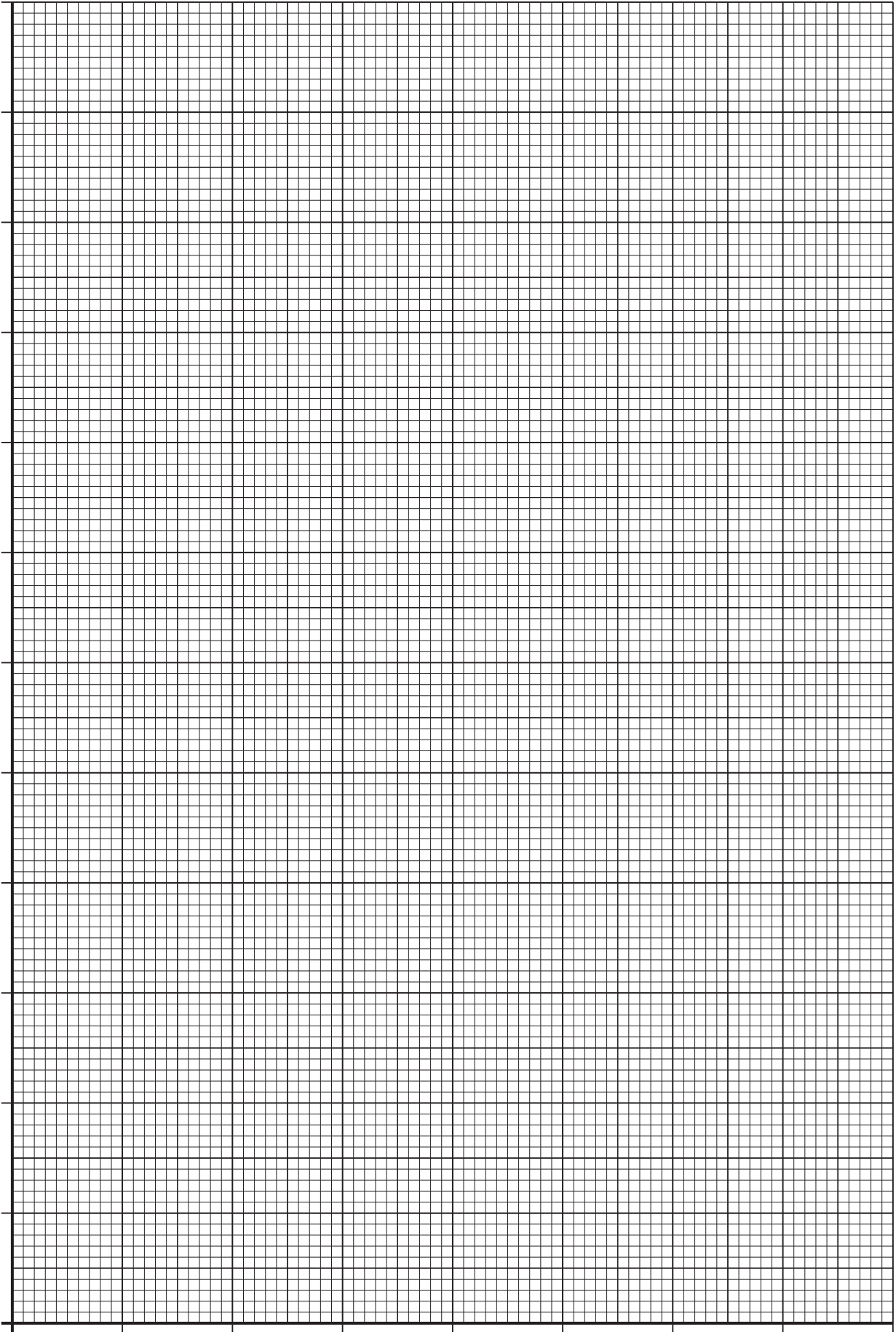

* X 8 5 7 7 5 0 1 4 4 *

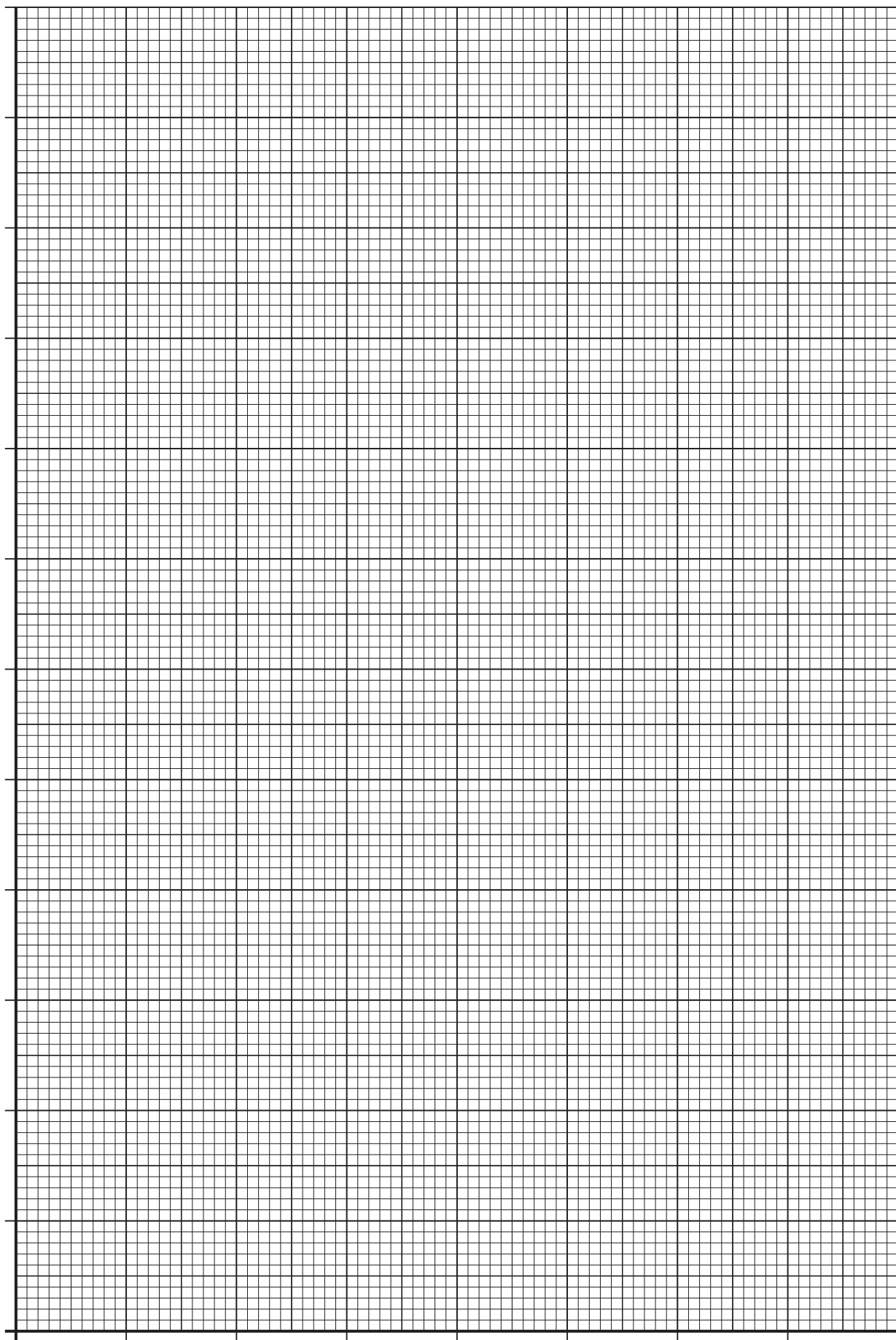

* X 8 5 7 7 5 0 1 4 5 *

ADDITIONAL SPACE FOR ANSWERS AND ROUGH WORK

Additional diagram for use with question 2 (b) (i)



Additional diagram for use with question 6 (a)

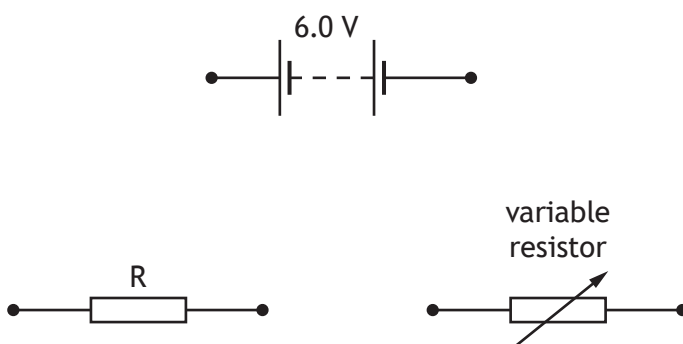

ADDITIONAL SPACE FOR ANSWERS AND ROUGH WORK

Additional graph paper for use with question 10 (b) (i)

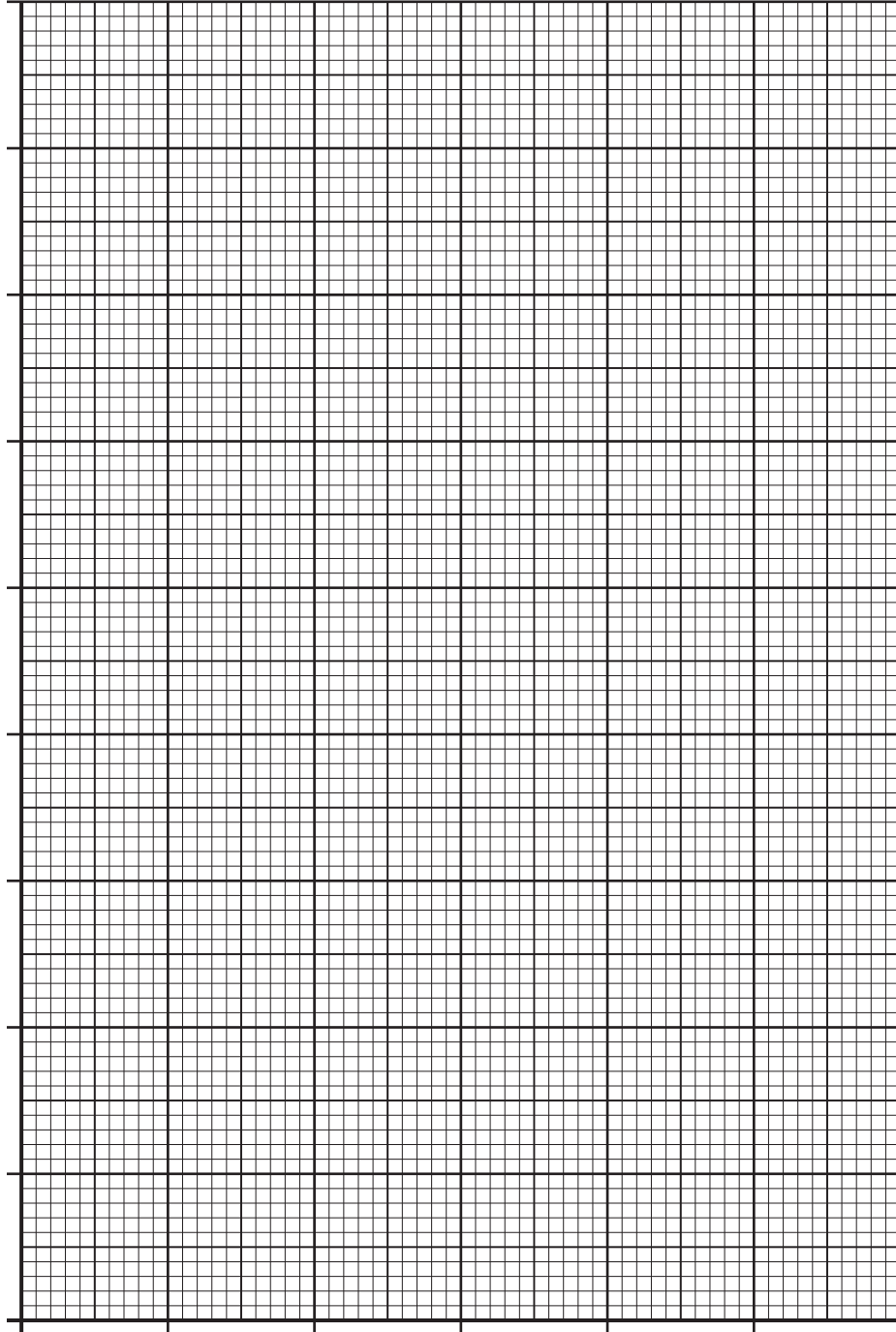

ADDITIONAL SPACE FOR ANSWERS AND ROUGH WORK

Additional diagram for use with question 13 (c)

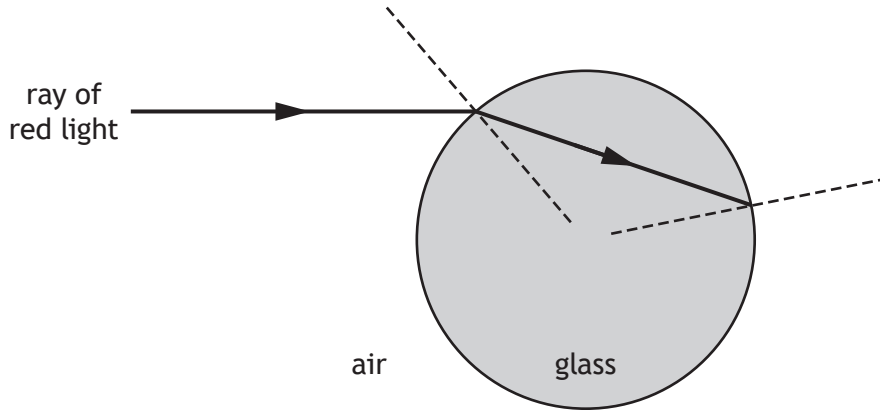

MARKS DO NOT
WRITE IN
THIS
MARGIN

ADDITIONAL SPACE FOR ANSWERS AND ROUGH WORK



* X 8 5 7 7 5 0 1 4 9 *

MARKS DO NOT
WRITE IN
THIS
MARGIN

ADDITIONAL SPACE FOR ANSWERS AND ROUGH WORK



* X 8 5 7 7 5 0 1 5 0 *

[BLANK PAGE]

DO NOT WRITE ON THIS PAGE



* X 8 5 7 7 5 0 1 5 1 *

[BLANK PAGE]

DO NOT WRITE ON THIS PAGE

Acknowledgement of copyright

- Question 2 Hasbul Aerial Stock/shutterstock.com
Question 3 Alexander Schedrov/shutterstock.com
Danny Iacob/shutterstock.com
Question 4 24K-Production/shutterstock.com
Question 12 Image of GPS device — Andrio/shutterstock.com
Image of rangefinder — LarsZ/shutterstock.com



* X 8 5 7 7 5 0 1 5 2 *