



National
Qualifications
2022

X857/75/02

Physics
Section 1 — Questions

FRIDAY, 13 MAY

1:00 PM – 3:30 PM

Instructions for the completion of Section 1 are given on *page 02* of your question and answer booklet X857/75/01.

Record your answers on the answer grid on *page 03* of your question and answer booklet.

Reference may be made to the Data Sheet on *page 02* of this booklet and to the Relationship Sheet X857/75/11.

Before leaving the examination room you must give your question and answer booklet to the Invigilator; if you do not, you may lose all the marks for this paper.



* X 8 5 7 7 5 0 2 *

DATA SHEET

Speed of light in materials

Material	Speed in m s^{-1}
Air	3.0×10^8
Carbon dioxide	3.0×10^8
Diamond	1.2×10^8
Glass	2.0×10^8
Glycerol	2.1×10^8
Water	2.3×10^8

Gravitational field strengths

	Gravitational field strength on the surface in N kg^{-1}
Earth	9.8
Jupiter	23
Mars	3.7
Mercury	3.7
Moon	1.6
Neptune	11
Saturn	9.0
Sun	270
Uranus	8.7
Venus	8.9

Specific latent heat of fusion of materials

Material	Specific latent heat of fusion in J kg^{-1}
Alcohol	0.99×10^5
Aluminium	3.95×10^5
Carbon Dioxide	1.80×10^5
Copper	2.05×10^5
Iron	2.67×10^5
Lead	0.25×10^5
Water	3.34×10^5

Specific latent heat of vaporisation of materials

Material	Specific latent heat of vaporisation in J kg^{-1}
Alcohol	11.2×10^5
Carbon Dioxide	3.77×10^5
Glycerol	8.30×10^5
Turpentine	2.90×10^5
Water	22.6×10^5

Speed of sound in materials

Material	Speed in m s^{-1}
Aluminium	5200
Air	340
Bone	4100
Carbon dioxide	270
Glycerol	1900
Muscle	1600
Steel	5200
Tissue	1500
Water	1500

Specific heat capacity of materials

Material	Specific heat capacity in $\text{J kg}^{-1} \text{ } ^\circ\text{C}^{-1}$
Alcohol	2350
Aluminium	902
Copper	386
Glass	500
Ice	2100
Iron	480
Lead	128
Oil	2130
Water	4180

Melting and boiling points of materials

Material	Melting point in $^\circ\text{C}$	Boiling point in $^\circ\text{C}$
Alcohol	-98	65
Aluminium	660	2470
Copper	1077	2567
Lead	328	1737
Iron	1537	2737
Water	-	100

Radiation weighting factors

Type of radiation	Radiation weighting factor
alpha	20
beta	1
fast neutrons	10
gamma	1
slow neutrons	3
X-rays	1

SECTION 1 — 25 marks

Attempt ALL questions

1. Which of the following contains one scalar quantity and one vector quantity?

- A acceleration; displacement
- B kinetic energy; speed
- C velocity; weight
- D potential energy; work
- E distance; force

2. The diagram shows a toy car at rest at the top of a slope.

The car is released and travels with a constant acceleration down the slope.

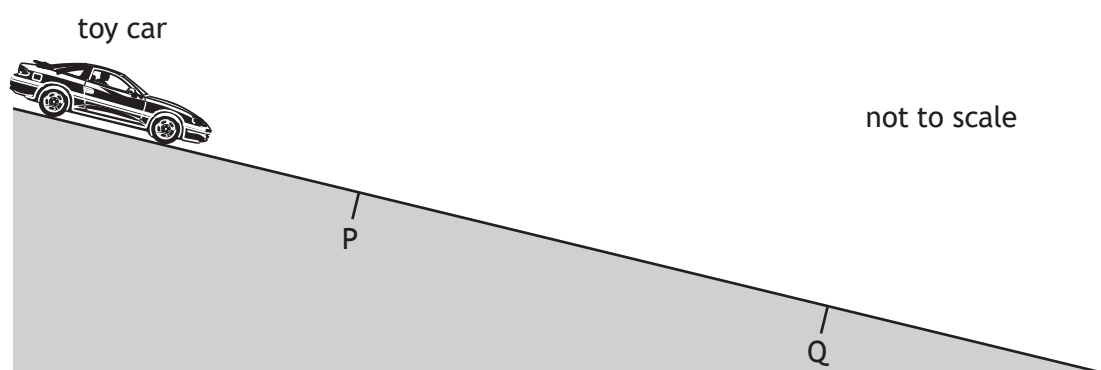

Which row in the table could show the speed of the toy car at P, the speed of the toy car at Q, and the average speed of the car between P and Q?

	Speed at P (m s^{-1})	Speed at Q (m s^{-1})	Average speed between P and Q (m s^{-1})
A	0	2	1
B	1	1	1
C	1	3	2
D	2	3	2
E	2	3	4

[Turn over

3. The graph of speed v against time t represents the motion of a cyclist over a 20 second period.

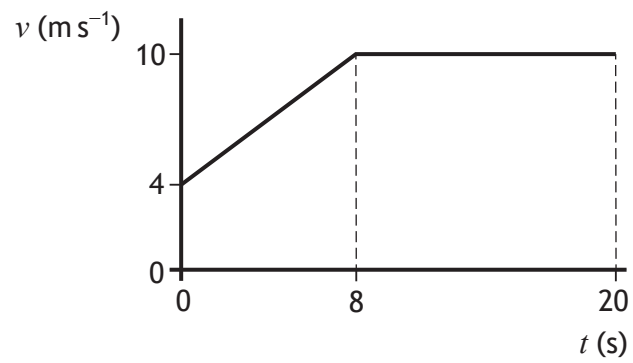

The distance travelled by the cyclist in the 20 second period is:

- A 56 m
- B 144 m
- C 160 m
- D 176 m
- E 200 m.

4. A student is investigating the motion of water rockets.

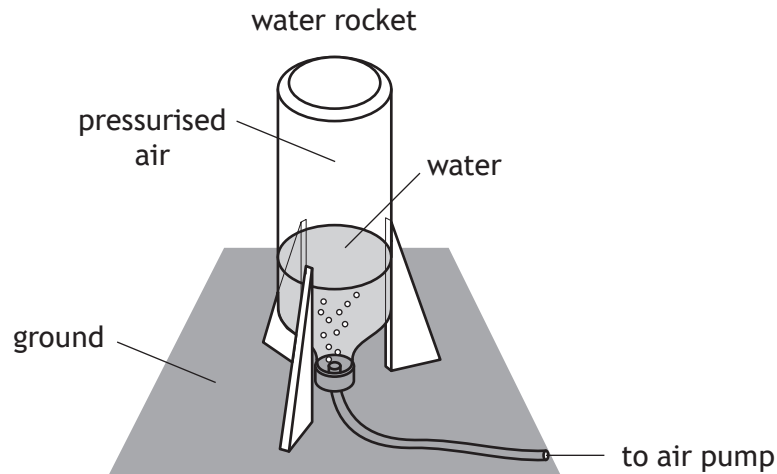

Air is pumped into the rocket until the pressure of the air inside is large enough for the water rocket to launch upwards.

The rocket launches because:

- A the rocket pushes down on the ground and the ground provides a reaction force pushing up on the rocket
- B the rocket pushes down on the water and the water provides a reaction force pushing up on the rocket
- C the water pushes down on the ground and the ground provides a reaction force pushing up on the water
- D the force applied by the water on the ground is greater than the weight of the rocket producing an unbalanced upward force
- E the weight of the rocket decreases as water is pushed out of the rocket producing an unbalanced upward force.

[Turn over

5. A ball of mass 0.25 kg is released from a height of 6.0 m above the ground.

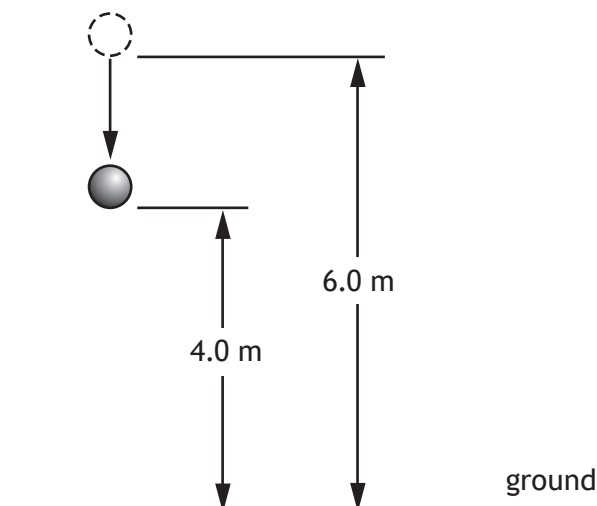

Which row in the table shows the change in gravitational potential energy and the kinetic energy of the ball when it is at a height of 4.0 m above the ground?

	Change in gravitational potential energy (J)	Kinetic energy (J)
A	14.7	0.0
B	4.9	4.9
C	9.8	4.9
D	4.9	9.8
E	14.7	14.7

6. Astronauts orbiting in the International Space Station experience 'weightlessness'.

A group of students make the following statements to explain 'weightlessness' in the orbiting space station:

- I The gravitational field strength inside the space station is zero.
- II The space station and astronauts are both accelerating at the same rate towards the Earth.
- III The forces acting on the astronauts are balanced.

Which of these statements is/are correct?

- A I only
- B II only
- C III only
- D I and II only
- E II and III only

7. Which of the following lists the distances from longest to shortest?

- A radius of Earth; radius of orbit of Moon; diameter of galaxy
- B radius of orbit of Moon; radius of Earth; diameter of galaxy
- C diameter of galaxy; radius of orbit of Moon; radius of Earth
- D diameter of galaxy; radius of Earth; radius of orbit of Moon
- E radius of orbit of Moon; diameter of galaxy; radius of Earth

8. Three satellites X, Y, and Z are orbiting the Earth as shown.

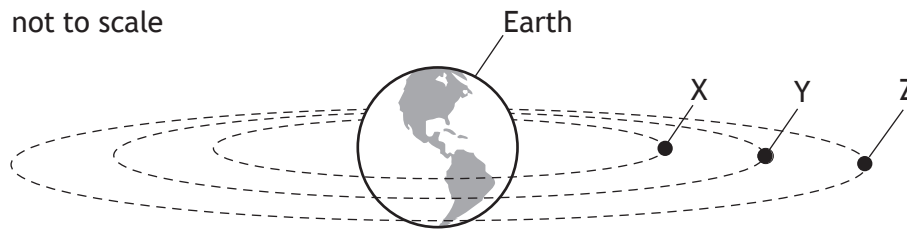

Satellite Z is a geostationary satellite.

Which row in the table shows possible periods for the orbits of satellites X, Y, and Z?

	Period of orbit of satellite X (hours)	Period of orbit of satellite Y (hours)	Period of orbit of satellite Z (hours)
A	12	18	24
B	24	18	12
C	24	24	24
D	40	36	24
E	4	6	12

[Turn over

9. A spacecraft has four rocket engines P, Q, R, and S and is travelling to the right as shown.

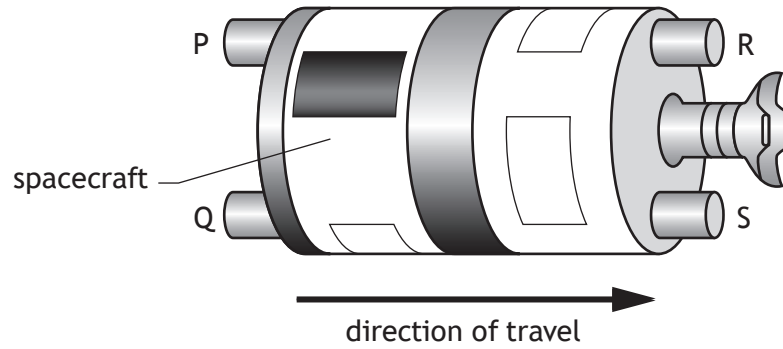

When switched on, each rocket engine produces the same amount of force.
Which rocket engines are switched on to reduce the speed of the spacecraft?

- A R and S
 - B Q and S
 - C P and Q
 - D P and R
 - E P, Q, R, and S
10. The weights of three masses on the surface of a planet are shown in the table.

Mass (kg)	Weight (N)
0.50	4.4
2.5	22
4.0	35

The weight of a 6.0 kg mass on the surface of the planet is:

- A 0.68 N
- B 1.5 N
- C 8.8 N
- D 53 N
- E 59 N.

11. A hair dryer is connected to a 230 V supply. The current in the hair dryer is 2.0 A.
The electrical charge that passes through the hair dryer in 5 minutes is:

- A 10 C
- B 460 C
- C 600 C
- D 1150 C
- E 2300 C.

12. The graph shows how the voltages across the components P, Q, and R vary with current.

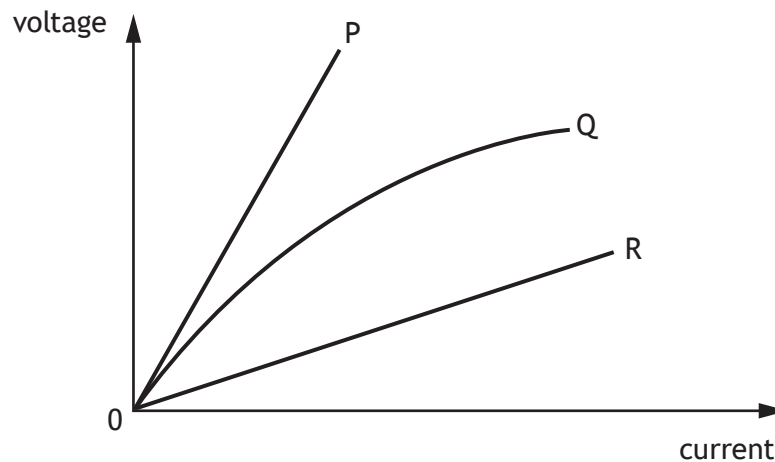

Based on this graph, a group of students make the following statements:

- I Component P has a greater resistance than component R.
- II Component R has a greater resistance than component Q.
- III Component Q has a resistance that decreases as the current increases.

Which of these statements is/are correct?

- A I only
- B II only
- C III only
- D I and III only
- E II and III only

[Turn over

13. A circuit is set up as shown.

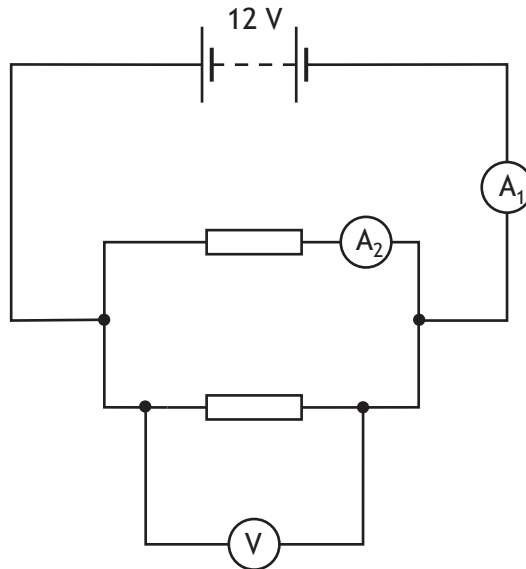

The resistors are identical.

Which row in the table shows the reading on the voltmeter and possible readings on ammeters A_1 and A_2 ?

	Reading on voltmeter (V)	Reading on ammeter A_1 (A)	Reading on ammeter A_2 (A)
A	6	0.3	0.3
B	6	0.6	0.3
C	12	0.3	0.3
D	12	0.3	0.6
E	12	0.6	0.3

14. Which of the following symbols represents a thermistor?

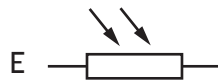
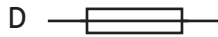
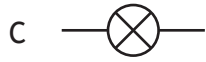
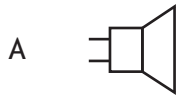

[Turn over

15. Two substances X and Y are both solid at 20 °C.

The substances have the same mass and are supplied with the same amount of energy per second.

The graph shows how the temperature of each substance varies with time.

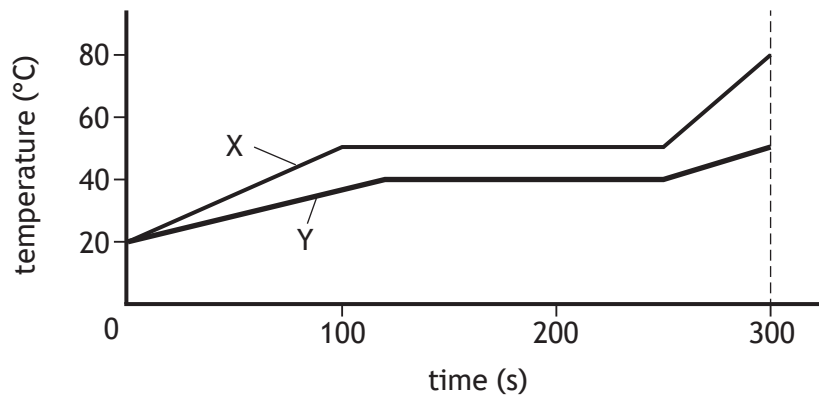

A student uses information from the graph to make the following statements:

- I The specific heat capacity of the solid substance X is greater than that of the solid substance Y.
- II Substance X changes state at a higher temperature than substance Y.
- III The specific latent heat of fusion of substance X is greater than that of substance Y.

Which of these statements is/are correct?

- A I only
 - B I and II only
 - C III only
 - D II and III only
 - E I, II and III
16. Heat from the Sun melts 1.6 kg of ice in 40 minutes.

The minimum heat energy required to change 1.6 kg of ice at 0 °C into water at 0 °C is:

- A 6.7×10^3 J
- B 1.3×10^4 J
- C 2.1×10^5 J
- D 5.3×10^5 J
- E 3.6×10^6 J.

17. A cyclist is riding a bicycle along a level road.



The combined mass of the cyclist and bicycle is 70.0 kg.

The total contact area between the tyres and the road is $8.0 \times 10^{-4} \text{ m}^2$.

The average pressure exerted by the tyres on the road is:

- A $1.2 \times 10^{-6} \text{ Pa}$
 - B $5.6 \times 10^{-2} \text{ Pa}$
 - C $8.8 \times 10^4 \text{ Pa}$
 - D $4.3 \times 10^5 \text{ Pa}$
 - E $8.6 \times 10^5 \text{ Pa}$.
18. The average kinetic energy of a gas molecule can be determined using the following relationship.

$$E_k = \frac{3}{2} k_B T$$

where: E_k is the average kinetic energy of a gas molecule in joules, J

k_B is Boltzmann's constant = $1.38 \times 10^{-23} \text{ J K}^{-1}$

T is the temperature of a gas molecule in kelvin, K.

The average kinetic energy of a gas molecule at 100 °C is:

- A $2.07 \times 10^{-21} \text{ J}$
- B $3.58 \times 10^{-21} \text{ J}$
- C $5.15 \times 10^{-21} \text{ J}$
- D $5.65 \times 10^{-21} \text{ J}$
- E $7.72 \times 10^{-21} \text{ J}$.

[Turn over

19. Which of the following is a longitudinal wave?
- A sound
 - B radio
 - C ultraviolet
 - D infrared
 - E light
20. A radio station transmits radio signals with a frequency range from 3.0 MHz to 6.0 MHz. The maximum wavelength of the radio signal transmitted is:
- A 0.01 m
 - B 0.02 m
 - C 50 m
 - D 100 m
 - E 113 m.
21. A student draws a diagram to show the bands of the electromagnetic spectrum in order of increasing wavelength.

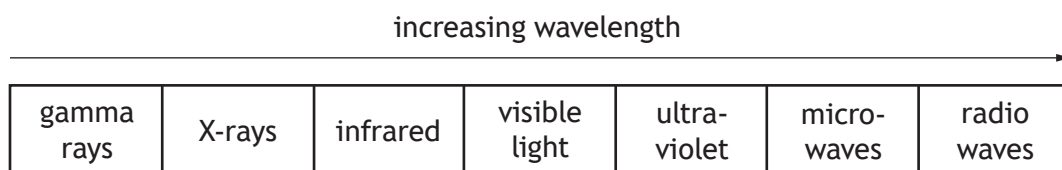

The diagram is **not** correct.

Which **two** bands of the electromagnetic spectrum are in the wrong position?

- A gamma rays and radio waves
- B X-rays and microwaves
- C infrared and ultraviolet
- D visible light and microwaves
- E X-rays and visible light

22. A radioactive source emits alpha, beta, and gamma radiations.
Sheets of aluminium and paper are placed in front of the source as shown.

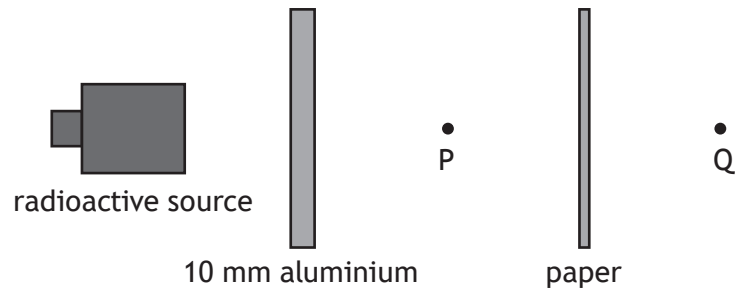

Which row in the table shows the radiation(s) from the source detected at points P and Q?

	Radiation(s) detected at P	Radiation(s) detected at Q
A	beta and gamma	gamma
B	beta	alpha
C	beta and gamma	beta and gamma
D	alpha and gamma	gamma
E	gamma	gamma

23. A radioactive sample emits 3000 alpha particles in 2 minutes.

The activity of the sample is:

- A 25 Bq
- B 1500 Bq
- C 3000 Bq
- D 6000 Bq
- E 360 000 Bq.

[Turn over

24. A radioactive substance is to be injected into a patient so that blood flow can be monitored using a detector.

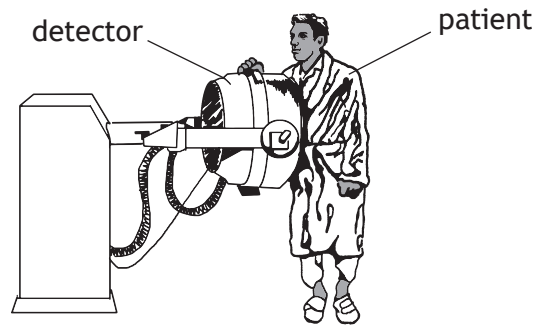

A number of different substances which emit either beta or gamma radiation are available. The substances have different half-lives.

Which row in the table identifies the radiation emitted and the half-life of the most suitable substance?

	Radiation emitted	Half-life
A	beta	2 days
B	beta	2 years
C	gamma	2 seconds
D	gamma	2 days
E	gamma	2 years

25. Rhodium-106 has a half-life of 30 s.
A sample of rhodium-106 has an activity of 3200 Bq.
The activity of this sample after 120 s is:

- A 27 Bq
- B 107 Bq
- C 200 Bq
- D 400 Bq
- E 800 Bq.

[END OF SECTION 1. NOW ATTEMPT THE QUESTIONS IN SECTION 2 OF YOUR QUESTION AND ANSWER BOOKLET]

SPACE FOR ROUGH WORK

SPACE FOR ROUGH WORK

[BLANK PAGE]

DO NOT WRITE ON THIS PAGE

[BLANK PAGE]

DO NOT WRITE ON THIS PAGE

Acknowledgement of copyright

Question 17 Friends Stock/shutterstock.com



FOR OFFICIAL USE

--	--	--	--	--	--

National
Qualifications
2022

Mark

--

X857/75/01

**Physics
Section 1 — Answer grid
and Section 2**

FRIDAY, 13 MAY

1:00 PM – 3:30 PM



Fill in these boxes and read what is printed below.

Full name of centre

--

Town

--

Forename(s)

--

Surname

--

Number of seat

--

Date of birth

Day

--	--

Month

--	--

Year

--	--

Scottish candidate number

--	--	--	--	--	--	--	--	--	--

Total marks — 135

SECTION 1 — 25 marks

Attempt ALL questions.

Instructions for completion of Section 1 are given on *page 02*.

SECTION 2 — 110 marks

Attempt ALL questions.

Reference may be made to the Data sheet on *page 02* of the question paper X857/75/02 and to the Relationships sheet X857/75/11.

Write your answers clearly in the spaces provided in this booklet. Additional space for answers and rough work is provided at the end of this booklet. If you use this space you must clearly identify the question number you are attempting. Any rough work must be written in this booklet. Score through your rough work when you have written your final copy.

Use **blue** or **black** ink.

Before leaving the examination room you must give this booklet to the Invigilator; if you do not, you may lose all the marks for this paper.



SECTION 1 — 25 marks

The questions for Section 1 are contained in the question paper X857/75/02.

Read these and record your answers on the answer grid on *page 03* opposite.

Use **blue** or **black** ink. Do NOT use gel pens or pencil.

1. The answer to each question is **either** A, B, C, D or E. Decide what your answer is, then fill in the appropriate bubble (see sample question below).
2. There is **only one correct** answer to each question.
3. Any rough work must be written in the additional space for answers and rough work at the end of this booklet.

Sample question

The energy unit measured by the electricity meter in your home is the:

- A ampere
- B kilowatt-hour
- C watt
- D coulomb
- E volt.

The correct answer is **B** — kilowatt-hour. The answer **B** bubble has been clearly filled in (see below).

A	B	C	D	E
<input type="radio"/>	<input checked="" type="radio"/>	<input type="radio"/>	<input type="radio"/>	<input type="radio"/>

Changing an answer

If you decide to change your answer, cancel your first answer by putting a cross through it (see below) and fill in the answer you want. The answer below has been changed to **D**.

A	B	C	D	E
<input type="radio"/>	<input checked="" type="radio"/>	<input type="radio"/>	<input checked="" type="radio"/>	<input type="radio"/>

If you then decide to change back to an answer you have already scored out, put a tick (✓) to the **right** of the answer you want, as shown below:

A	B	C	D	E	or	A	B	C	D	E
<input type="radio"/>	<input checked="" type="radio"/>	<input type="radio"/>	<input checked="" type="radio"/>	<input type="radio"/>		<input type="radio"/>	<input checked="" type="radio"/>	<input type="radio"/>	<input type="radio"/>	<input type="radio"/>



SECTION 1 — Answer grid



	A	B	C	D	E
1	<input type="radio"/>	<input type="radio"/>	<input type="radio"/>	<input type="radio"/>	<input type="radio"/>
2	<input type="radio"/>	<input type="radio"/>	<input type="radio"/>	<input type="radio"/>	<input type="radio"/>
3	<input type="radio"/>	<input type="radio"/>	<input type="radio"/>	<input type="radio"/>	<input type="radio"/>
4	<input type="radio"/>	<input type="radio"/>	<input type="radio"/>	<input type="radio"/>	<input type="radio"/>
5	<input type="radio"/>	<input type="radio"/>	<input type="radio"/>	<input type="radio"/>	<input type="radio"/>
6	<input type="radio"/>	<input type="radio"/>	<input type="radio"/>	<input type="radio"/>	<input type="radio"/>
7	<input type="radio"/>	<input type="radio"/>	<input type="radio"/>	<input type="radio"/>	<input type="radio"/>
8	<input type="radio"/>	<input type="radio"/>	<input type="radio"/>	<input type="radio"/>	<input type="radio"/>
9	<input type="radio"/>	<input type="radio"/>	<input type="radio"/>	<input type="radio"/>	<input type="radio"/>
10	<input type="radio"/>	<input type="radio"/>	<input type="radio"/>	<input type="radio"/>	<input type="radio"/>
11	<input type="radio"/>	<input type="radio"/>	<input type="radio"/>	<input type="radio"/>	<input type="radio"/>
12	<input type="radio"/>	<input type="radio"/>	<input type="radio"/>	<input type="radio"/>	<input type="radio"/>
13	<input type="radio"/>	<input type="radio"/>	<input type="radio"/>	<input type="radio"/>	<input type="radio"/>
14	<input type="radio"/>	<input type="radio"/>	<input type="radio"/>	<input type="radio"/>	<input type="radio"/>
15	<input type="radio"/>	<input type="radio"/>	<input type="radio"/>	<input type="radio"/>	<input type="radio"/>
16	<input type="radio"/>	<input type="radio"/>	<input type="radio"/>	<input type="radio"/>	<input type="radio"/>
17	<input type="radio"/>	<input type="radio"/>	<input type="radio"/>	<input type="radio"/>	<input type="radio"/>
18	<input type="radio"/>	<input type="radio"/>	<input type="radio"/>	<input type="radio"/>	<input type="radio"/>
19	<input type="radio"/>	<input type="radio"/>	<input type="radio"/>	<input type="radio"/>	<input type="radio"/>
20	<input type="radio"/>	<input type="radio"/>	<input type="radio"/>	<input type="radio"/>	<input type="radio"/>
21	<input type="radio"/>	<input type="radio"/>	<input type="radio"/>	<input type="radio"/>	<input type="radio"/>
22	<input type="radio"/>	<input type="radio"/>	<input type="radio"/>	<input type="radio"/>	<input type="radio"/>
23	<input type="radio"/>	<input type="radio"/>	<input type="radio"/>	<input type="radio"/>	<input type="radio"/>
24	<input type="radio"/>	<input type="radio"/>	<input type="radio"/>	<input type="radio"/>	<input type="radio"/>
25	<input type="radio"/>	<input type="radio"/>	<input type="radio"/>	<input type="radio"/>	<input type="radio"/>



[BLANK PAGE]

DO NOT WRITE ON THIS PAGE



[Turn over for SECTION 2

DO NOT WRITE ON THIS PAGE



* X 8 5 7 7 5 0 1 0 5 *

SECTION 2 — 110 marks

Attempt ALL questions

MARKS
DO NOT
WRITE IN
THIS
MARGIN

1. An aeroplane flies from Aberdeen to Glasgow.

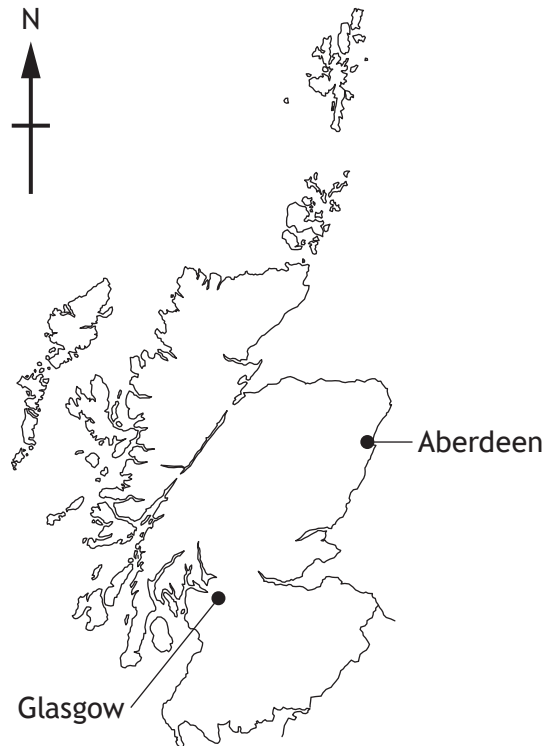

The aeroplane flies 140 km due south (180) from Aberdeen, then 130 km due west (270) to Glasgow.

- (a) By scale diagram, or otherwise:

- (i) determine the magnitude of the displacement from Aberdeen to Glasgow **2**
Space for working and answer



1. (a) (continued)

MARKS DO NOT WRITE IN THIS MARGIN

- (ii) determine the direction of the displacement from Aberdeen to Glasgow.

2

Space for working and answer

- (b) On the return journey, the aeroplane flies **directly** from Glasgow to Aberdeen. The journey takes 0.50 hours.

- (i) Calculate the average speed of the aeroplane for this journey.

3

Space for working and answer

- (ii) Determine the average velocity of the aeroplane from Glasgow to Aberdeen.

2

Space for working and answer



* X 8 5 7 7 5 0 1 0 7 *

2. A student is investigating factors that affect the horizontal range of a marble, using the apparatus shown.

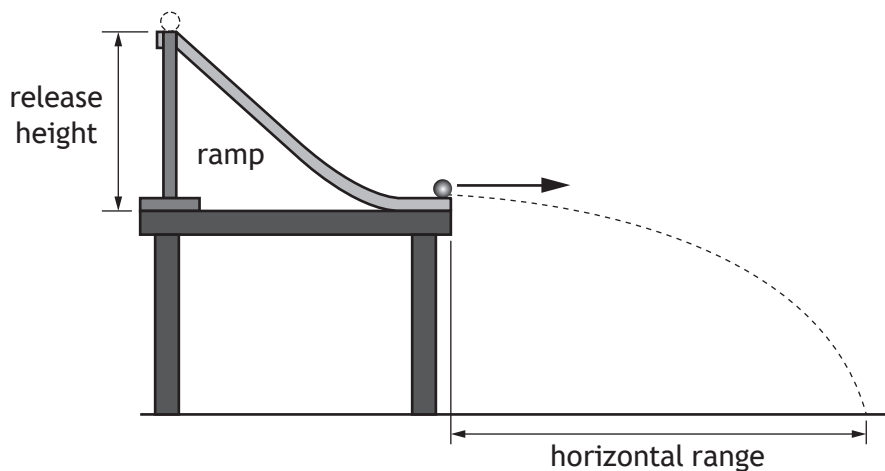

- (a) The student releases a marble from different heights on the ramp and measures the horizontal range.

The student's results are shown in the table.

Release height (m)	Horizontal range (m)
0.10	0.39
0.14	0.44
0.18	0.51
0.26	0.64
0.30	0.70

- (i) Using the graph paper on *page 09*, draw a graph of these results. (Additional graph paper, if required, can be found on *page 46*.)

3



2. (a) (i) (continued)

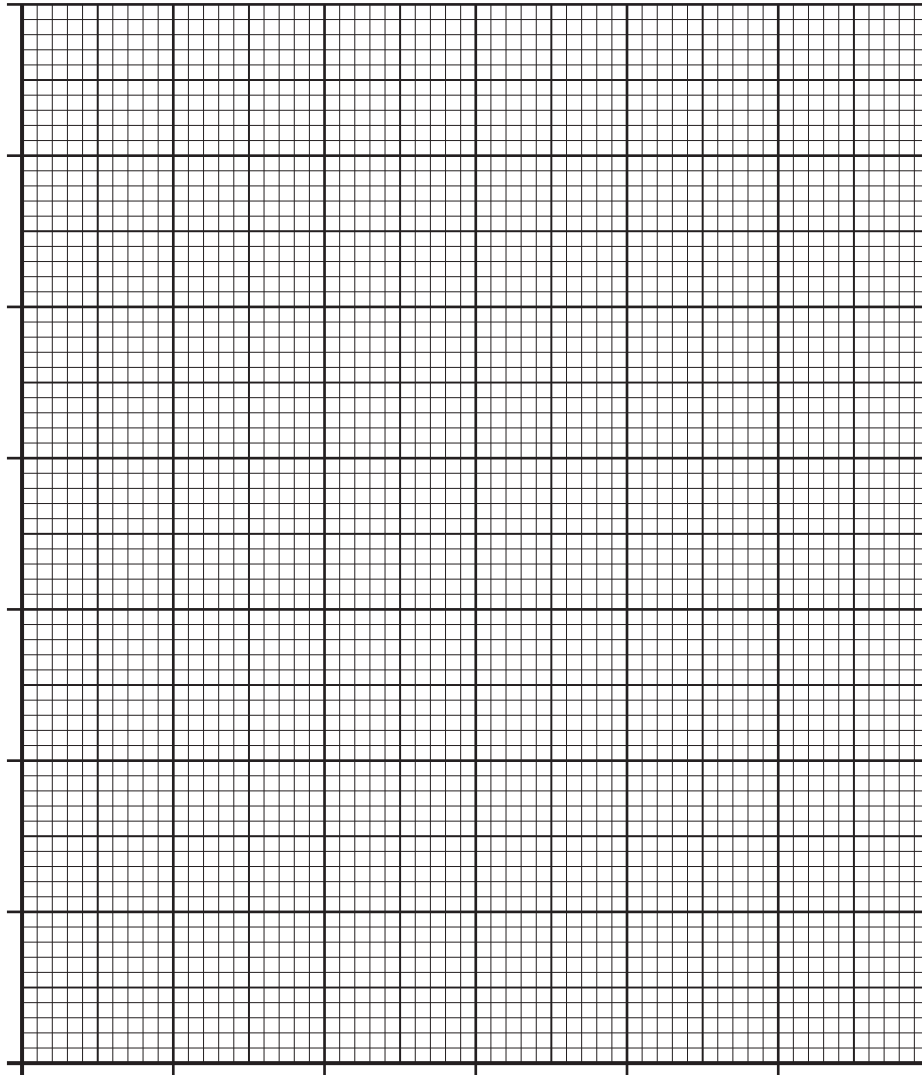

(ii) Use your graph to predict the horizontal range of a marble released from a height of 0.22 m.

1



2. (a) (continued)

- (iii) In order to measure the horizontal range, the student watched to see where the marble hit the ground.

Suggest an improvement to the experiment to determine more accurately where the marble hit the ground.

1

- (b) (i) Suggest another variable that could be investigated, which may affect the horizontal range of a marble.

1

- (ii) Describe experimental work that could be carried out to investigate how the variable you suggested in (b) (i) affects the horizontal range of a marble.

2



* X 8 5 7 7 5 0 1 1 0 *

[Turn over for next question

DO NOT WRITE ON THIS PAGE



* X 8 5 7 7 5 0 1 1 1 *

3. A spaceship on Mars is being prepared for the return journey to Earth.

MARKS
DO NOT
WRITE IN
THIS
MARGIN



- (a) The mass of the spaceship including fuel and crew is 1.3×10^6 kg.
The rocket engines on the spaceship produce a constant upward thrust of 1.2×10^7 N.

(i) Calculate the weight of the spaceship on Mars.

3

Space for working and answer

- (ii) On the diagram below, show all the forces acting vertically on the spaceship just after it leaves the surface.

You must name these forces and show their directions.

2

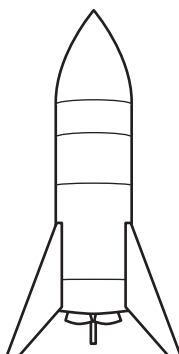

(An additional diagram, if required, can be found on page 47.)



3. (a) (continued)

(iii) Determine the acceleration of the spaceship at launch.

4

Space for working and answer

(b) State what happens to the acceleration of the spaceship as its altitude increases.

2

Justify your answer.

[Turn over



* X 8 5 7 7 5 0 1 1 3 *

4. Space exploration is often in the news, yet we have only explored about 5% of the oceans on Earth.

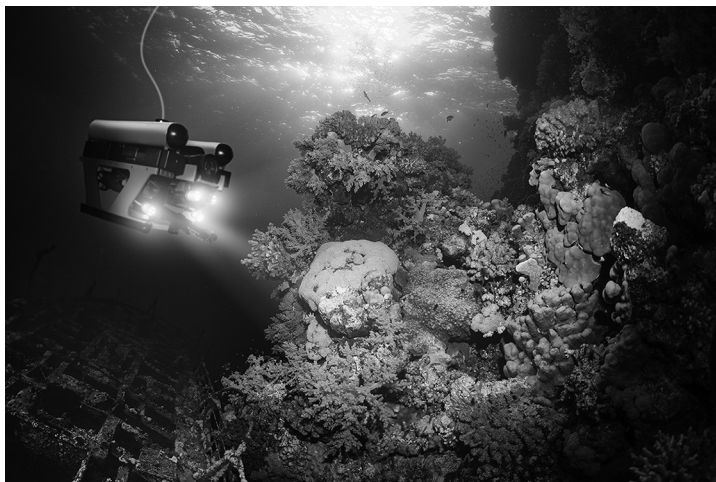

Using your knowledge of physics, comment on the similarities and/or differences between space exploration and underwater exploration.

3



4. (continued)



* X 8 5 7 7 5 0 1 1 5 *

5. Read the passage and answer the questions that follow.

Making plans for Rigel

Betelgeuse might be regularly mentioned in the news but there are other supergiants in the night sky. One of these is Rigel, a blue supergiant star that makes up the 'left foot' of the constellation of Orion. It is approximately 8 million years old and is one of the brightest stars in our night sky.

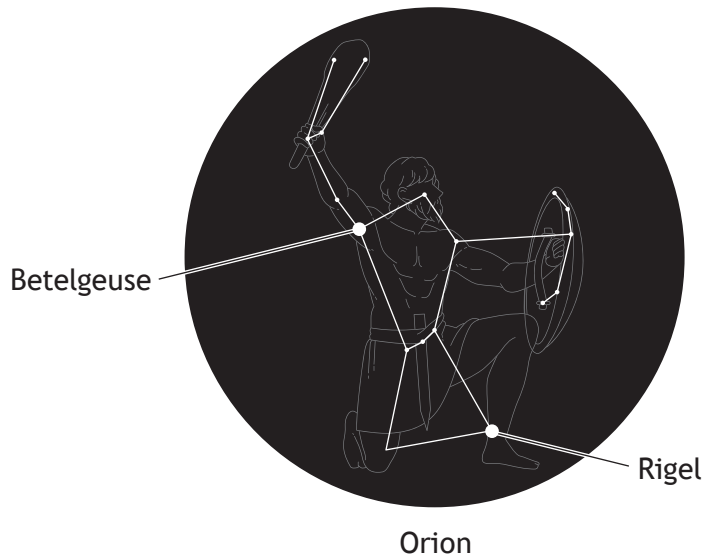

Blue supergiants, such as Rigel, are short-lived and are destined to explode as a supernova. Even though Rigel is 860 light-years from Earth, the supernova will be clear to see. Astronomers believe that it will be as bright as a half-moon and will be visible in the sky during the day. However, the light show will only last a few months before it fades.

When it explodes, Rigel will throw debris into space at approximately 5% of the speed of light. Intense waves of radiation, including X-rays and gamma rays, will be radiated into space. The core of the star will collapse into an extremely dense ball of nuclear matter called a neutron star.

It is not possible to predict exactly when Rigel will explode and there is the possibility that it has already happened, it just hasn't been detected yet! The best estimate scientists have is that it will take place within the next million years, or so.



5. (continued)

MARKS
DO NOT
WRITE IN
THIS
MARGIN

- (a) (i) Calculate the distance, in metres, from Rigel to Earth.

3

Space for working and answer

- (ii) Determine the approximate speed of the debris that will be ejected from the star during the supernova explosion.

1

Space for working and answer

- (iii) Calculate the time it would take for this debris to reach Earth.

3

Space for working and answer

- (b) Explain why the supernova explosion may already have happened but has not yet been detected.

1



* X 8 5 7 7 5 0 1 1 7 *

5. (continued)

- (c) Astronomers can identify elements present in stars by studying the spectrum of the light they produce.

A spectrum from a star is shown.



- (i) State the type of spectrum shown. 1
- (ii) Explain how the spectrum can be used to identify the elements present in the star. 1



[Turn over for next question

DO NOT WRITE ON THIS PAGE



* X 8 5 7 7 5 0 1 1 9 *

6. A ceramic power resistor is a common type of resistor, used in circuits to dissipate large amounts of energy as heat. They are labelled with a power rating and resistance value.

MARKS

DO NOT
WRITE IN
THIS
MARGIN

Two examples are shown.

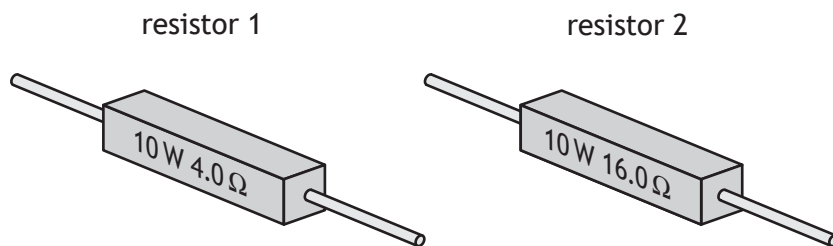

- (a) State which of the two resistors will allow the greater current to pass.
You must justify your answer.

2

- (b) The resistors are connected in the circuit shown.

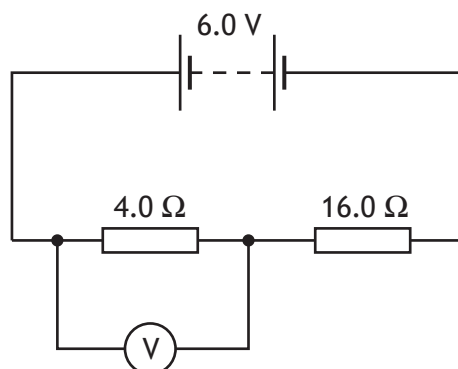

Calculate the reading on the voltmeter.

3

Space for working and answer



* X 8 5 7 7 5 0 1 2 0 *

6. (continued)

(c) The two resistors are now connected in another circuit as shown.

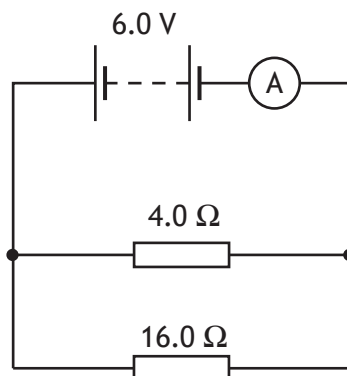

(i) Calculate the total resistance of the circuit.

3

Space for working and answer

(ii) Another ceramic power resistor is now connected in parallel with the two resistors in the circuit.

State the effect this change has on the reading on the ammeter.

Justify your answer.

2



7. A dehumidifier is an appliance that extracts water from the air around it.

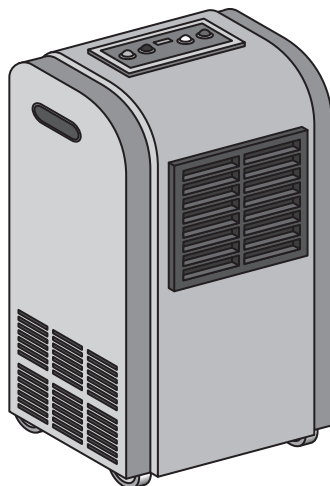

One particular dehumidifier operates at 230 V a.c. and has a power rating of 0.35 kW.

(a) State the fuse rating that should be used for this dehumidifier. 1

(b) Calculate the resistance of the dehumidifier. 3
Space for working and answer



7. (continued)

- (c) The dehumidifier switches on automatically when the moisture in the air increases above a certain level. This causes an LED to light and a fan to turn on.

Part of the circuit diagram for the circuit is shown.

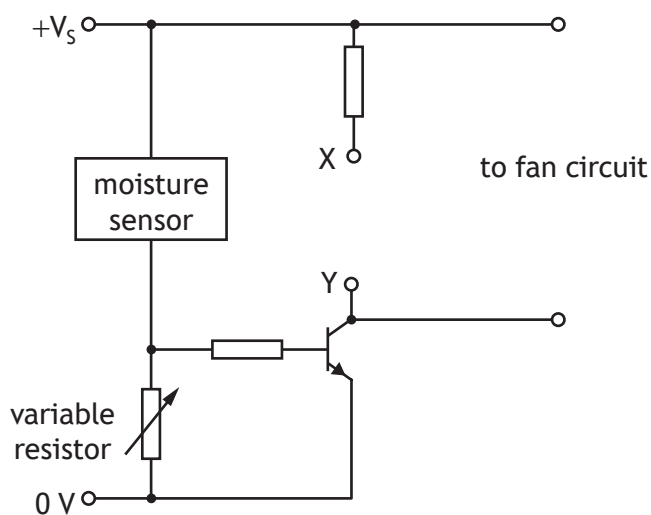

- (i) Complete the circuit diagram to show the LED connected correctly between X and Y.

1

(An additional diagram, if required, can be found on *page 48*.)

- (ii) The voltage across the moisture sensor decreases as the moisture in the air increases.

Explain how the circuit operates to turn on the LED when the moisture in the air increases above a certain level.

2

- (iii) Explain the purpose of the variable resistor in this circuit.

1



8. An electric iron operates at 230 V a.c.
The power rating of the iron is 1750 W.



- (a) Calculate the current in the iron when it is operating.
Space for working and answer

3



8. (continued)

- (b) When the iron is switched on, it takes 72.0 s for the soleplate to reach the correct temperature.

During this time, 126 000 J of energy is transferred to the soleplate.

- (i) The soleplate is made from aluminium.

The mass of the soleplate is 0.650 kg.

The initial temperature of the soleplate is 22 °C.

Determine the maximum temperature reached by the soleplate.

4

Space for working and answer

- (ii) Explain why the maximum temperature reached by the soleplate will be less than that calculated in (b) (i).

1

[Turn over



9. A group of students are investigating how the pressure of a fixed mass of gas varies with its temperature. This is known as Gay-Lussac's Law.

The students set up an experiment as shown.

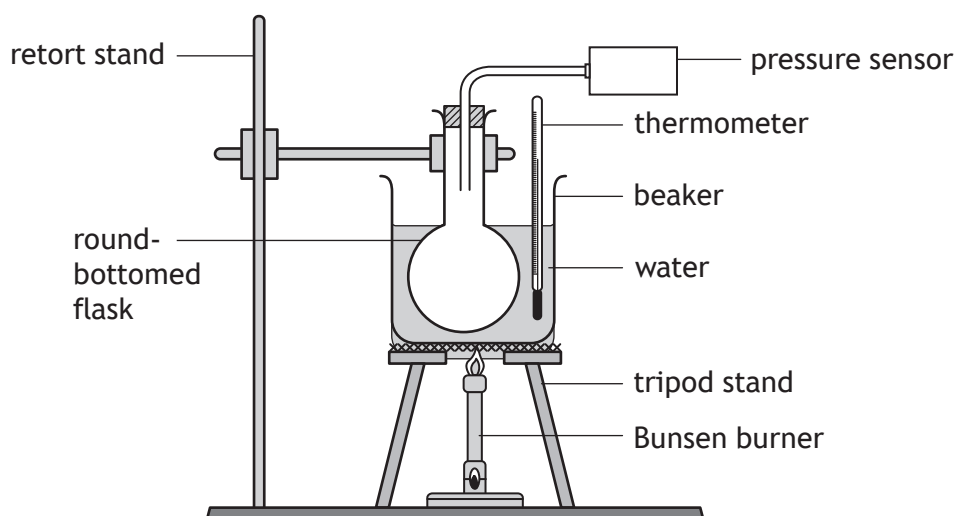

The round-bottomed flask contains a fixed mass of gas.

The Bunsen burner is used to heat the apparatus as shown. Readings of temperature and pressure are taken every 10 °C.

During the experiment the volume of the gas in the round-bottomed flask remains constant.

The students' results are shown.

Temperature (°C)	Temperature (K)	Pressure (kPa)
50	323	121
60	333	124
70	343	128
80	353	132



* X 8 5 7 7 5 0 1 2 6 *

9. (continued)

- (a) Use **all** the appropriate data to establish the relationship between the pressure and the temperature of the gas.

3

Space for working and answer

- (b) Predict the pressure of the gas at a temperature of 100 °C.

1

- (c) Suggest one way the students could improve the experiment.

1

[Turn over



* X 8 5 7 7 5 0 1 2 7 *

9. (continued)

(d) The tyre pressure in racing cars is carefully monitored throughout a race.

As the cars drive around the racing circuit, the temperature of the gas inside the tyres increases.

Explain, using the kinetic model, how this affects the pressure of the gas inside the tyres.

3



* X 8 5 7 7 5 0 1 2 8 *

[Turn over for next question

DO NOT WRITE ON THIS PAGE



* X 8 5 7 7 5 0 1 2 9 *

10. A student sets up a ripple tank. A ripple tank is a shallow tank of water used to demonstrate wave properties.

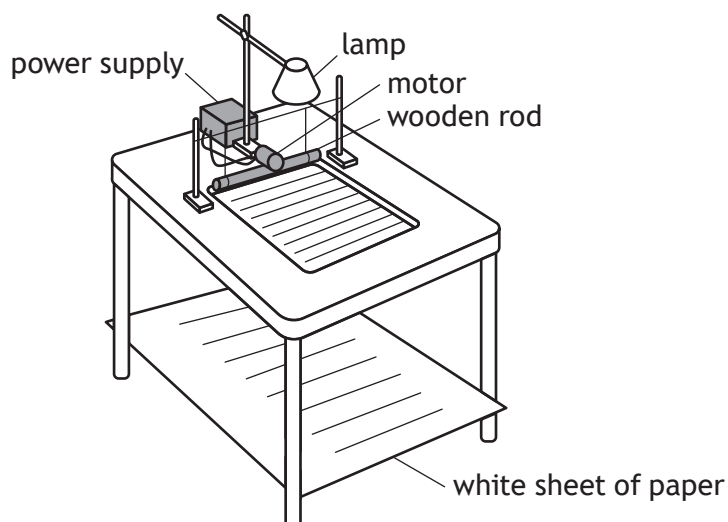

The wooden rod moves in and out of the water to generate water waves.

The pattern of the water waves is projected onto a white sheet of paper below the tank.

The wave pattern appears on the paper as a series of bright and dark lines. The dark lines correspond to the wave crests.

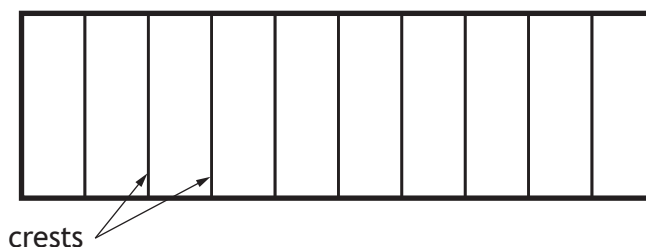

- (a) The student determines that there are six complete waves in 0.12 m.

- (i) Determine the wavelength of the waves.

Space for working and answer

1



10. (a) (continued)

MARKS DO NOT WRITE IN THIS MARGIN

(ii) The six complete waves are produced in a time of 0.40 s.

Show that the frequency of the waves is 15 Hz.

Space for working and answer

2

(iii) Calculate the speed of the waves.

Space for working and answer

3

(b) The student now places a plastic block in the ripple tank.

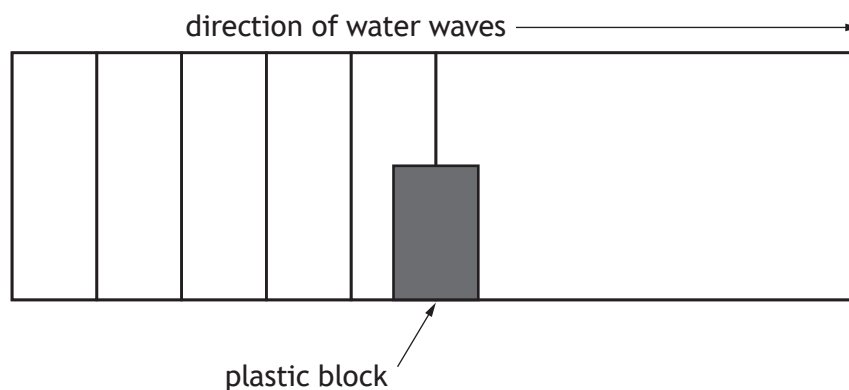

Complete the diagram to show the pattern of the water waves beyond the plastic block.

(An additional diagram, if required, can be found on *page 48*.)

2



11. A laser produces a narrow beam of concentrated light of one particular wavelength.

(a) A ray of red light from a laser is directed into a semi-circular glass block.

(i) When the ray of red light enters the block its speed changes.
State the name given to this effect.

1

(ii) Complete the diagram to show the path of the ray of red light through and out of the semi-circular glass block.

1

(An additional diagram, if required, can be found on page 49.)

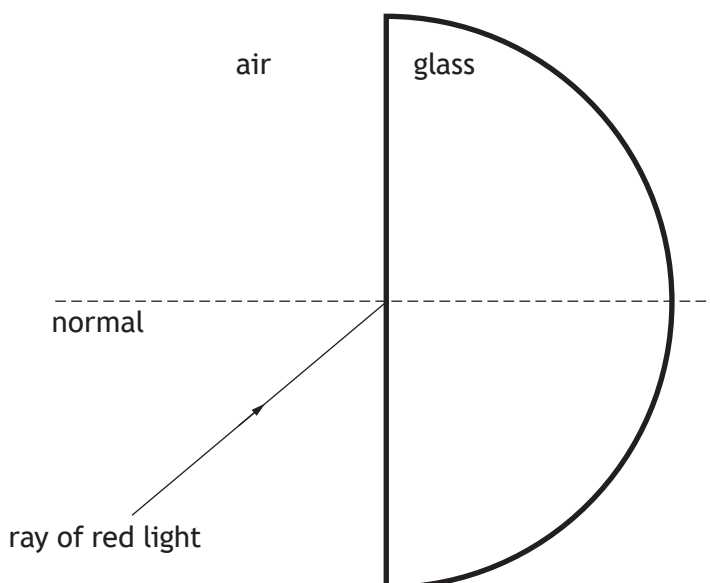

(iii) State how the wavelength of the red light in the glass compares to the wavelength of the red light in air.

1



11. (continued)

- (b) The table gives information about the wavelength and output power of various lasers.

Type of laser	Wavelength (nm)	Output power (W)
Argon	514	20
CO ₂	10 600	25
Diode	980	10
Nd:YAG	1064	3.0

Light from a CO₂ laser is used in dental treatment.



During the dental treatment the CO₂ laser emits short pulses of light.

The average energy per pulse of light is 42.5 mJ.

Calculate the average time for each pulse.

3

Space for working and answer



12. A student uses a Leslie's cube and thermopile to investigate the amount of infrared radiation emitted by different surfaces of the cube.

A Leslie's cube is a hollow metal cube. Four sides of the cube have different finishes: matt white, matt black, shiny silver, and shiny black.

Darker surfaces emit more infrared radiation than lighter surfaces. Matt surfaces emit more infrared radiation than shiny surfaces.

A thermopile is a device that produces a voltage proportional to the amount of infrared radiation detected.

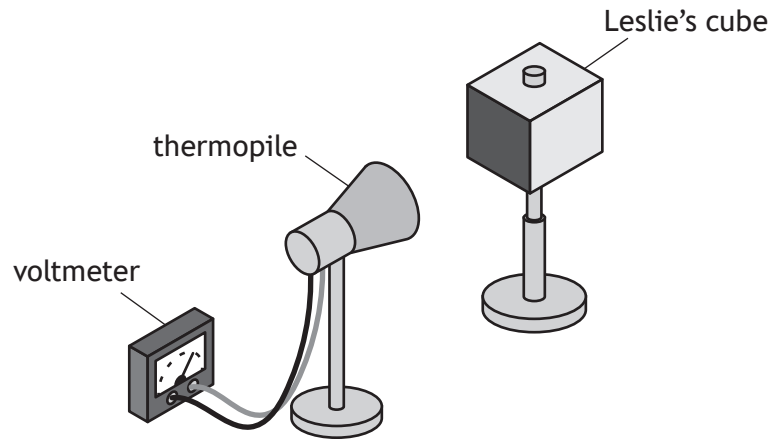

The student fills the cube with hot water and measures the amount of infrared radiation at different distances from the cube, using the thermopile.

- (a) The student produces a graph of their results for the matt black side.

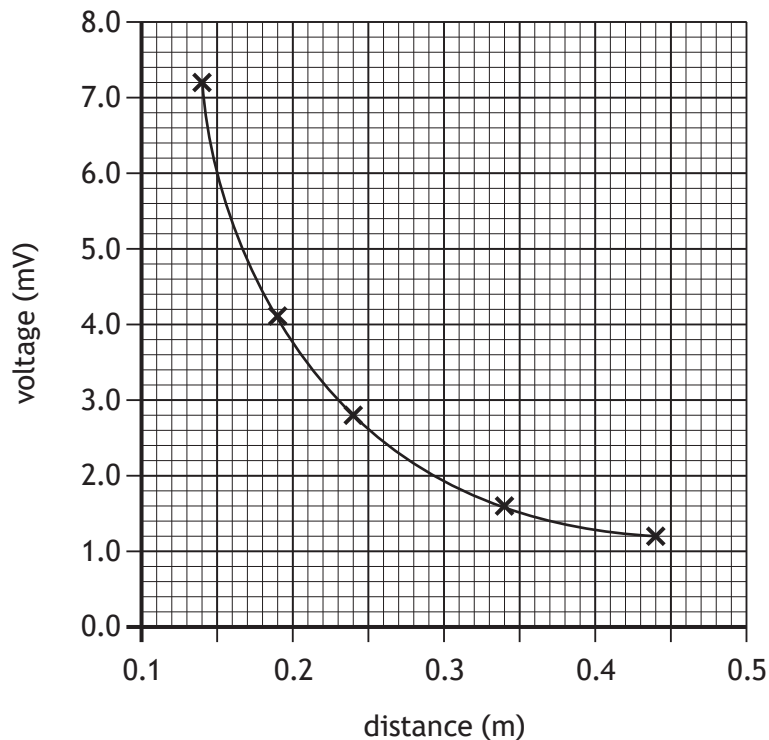

12. (a) (continued)

(i) State a conclusion that can be made about how the distance from a Leslie's cube affects the amount of infrared radiation detected by the thermopile.

1

(ii) The experiment is repeated using the shiny silver side.

On the graph below, draw a line to show how the voltage produced by the thermopile varies with distance for the shiny silver side.

2

(An additional graph, if required, can be found on page 49.)

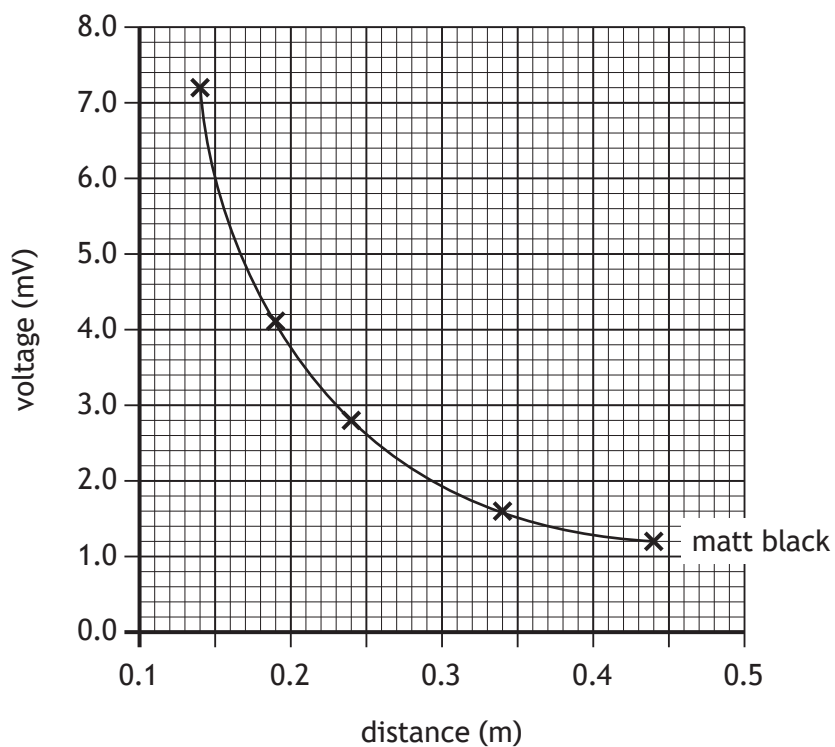

[Turn over



12. (continued)

- (b) A solar shower consists of a heavy-duty plastic bag, with a matt black surface and a shiny silver surface, connected to a hose and shower head. The bag uses infrared radiation from the Sun to heat water for a shower, when camping.

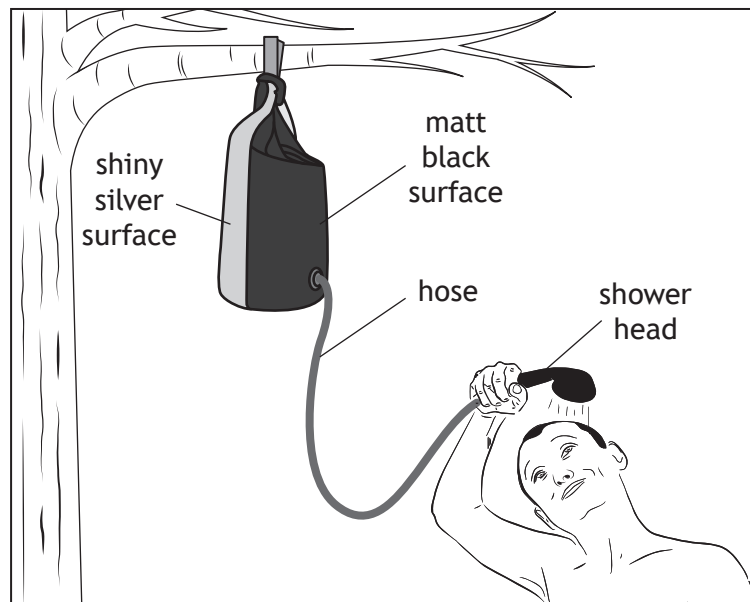

Using your knowledge of physics, comment on how the solar shower works.

3



12. (b) (continued)



* X 8 5 7 7 5 0 1 3 7 *

13. Smoke detectors are designed to automatically detect smoke and give a warning. It is recommended that smoke detectors are replaced every ten years.



Inside the smoke detector a radioactive source causes ionisation of the air between two electrically charged plates. When smoke enters the detector, the ionisation of the air is reduced.

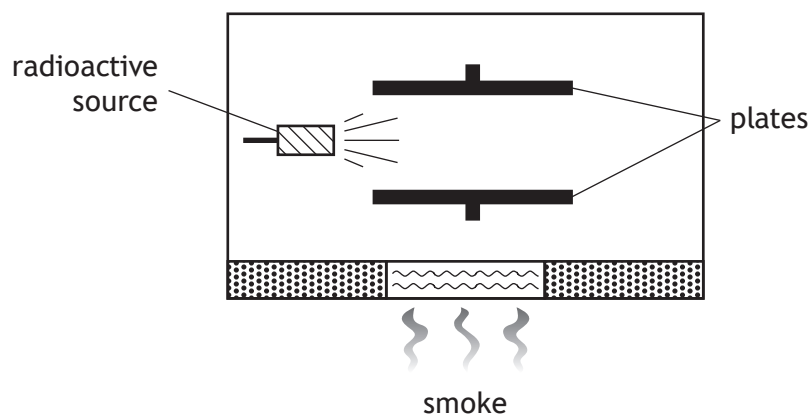

In most smoke detectors the radioactive source used is americium-241, which emits alpha particles.

- (a) Give **two** reasons why an alpha radiation source is used rather than a beta or gamma source.

2



13. (continued)

(b) The graphs show how the activity of three different alpha sources X, Y, and Z change with time.

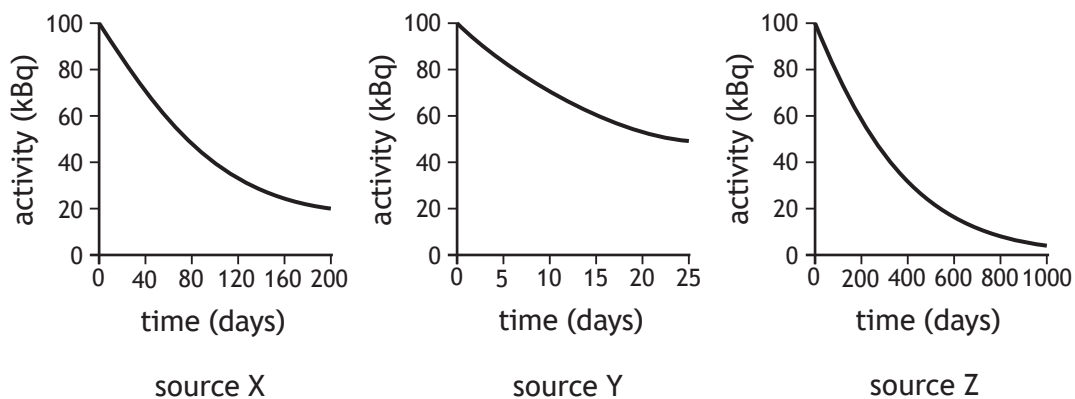

(i) State which of these three sources has the longest half-life.

1

(ii) Explain why these sources would **not** be suitable for use in a smoke detector.

2

[Turn over



13. (continued)

- (c) Manufacturers must meet health and safety standards for their radiation workers.

During an 8-hour shift, a radiation worker receives an absorbed dose of 4.5 μGy every hour from alpha radiation.

Determine the equivalent dose received by the worker in the 8-hour shift.

4

Space for working and answer



* X 8 5 7 7 5 0 1 4 0 *

[Turn over for next question

DO NOT WRITE ON THIS PAGE



* X 8 5 7 7 5 0 1 4 1 *

14. Nuclear fission is used in nuclear reactors to generate electricity.
Nuclear fusion happens naturally in stars such as the Sun.

MARKS DO NOT WRITE IN THIS MARGIN

(a) State what is meant by the term *nuclear fission*.

1

(b) Electricity generated from nuclear fission reactions is used to power the engines of an icebreaker ship.



(i) The power output of the nuclear reactor in the icebreaker ship is 150 MW.

Each nuclear fission reaction releases 2.9×10^{-11} J of energy.

Determine the minimum number of fission reactions that occur in the reactor each hour.

4

Space for working and answer



14. (b) (continued)

- (ii) For many years, scientists have been attempting to develop nuclear fusion reactors. Current fusion reactors can only sustain reactions for a limited period of time.

Describe one difficulty in sustaining nuclear fusion reactions in a reactor.

1

[END OF QUESTION PAPER]



* X 8 5 7 7 5 0 1 4 3 *

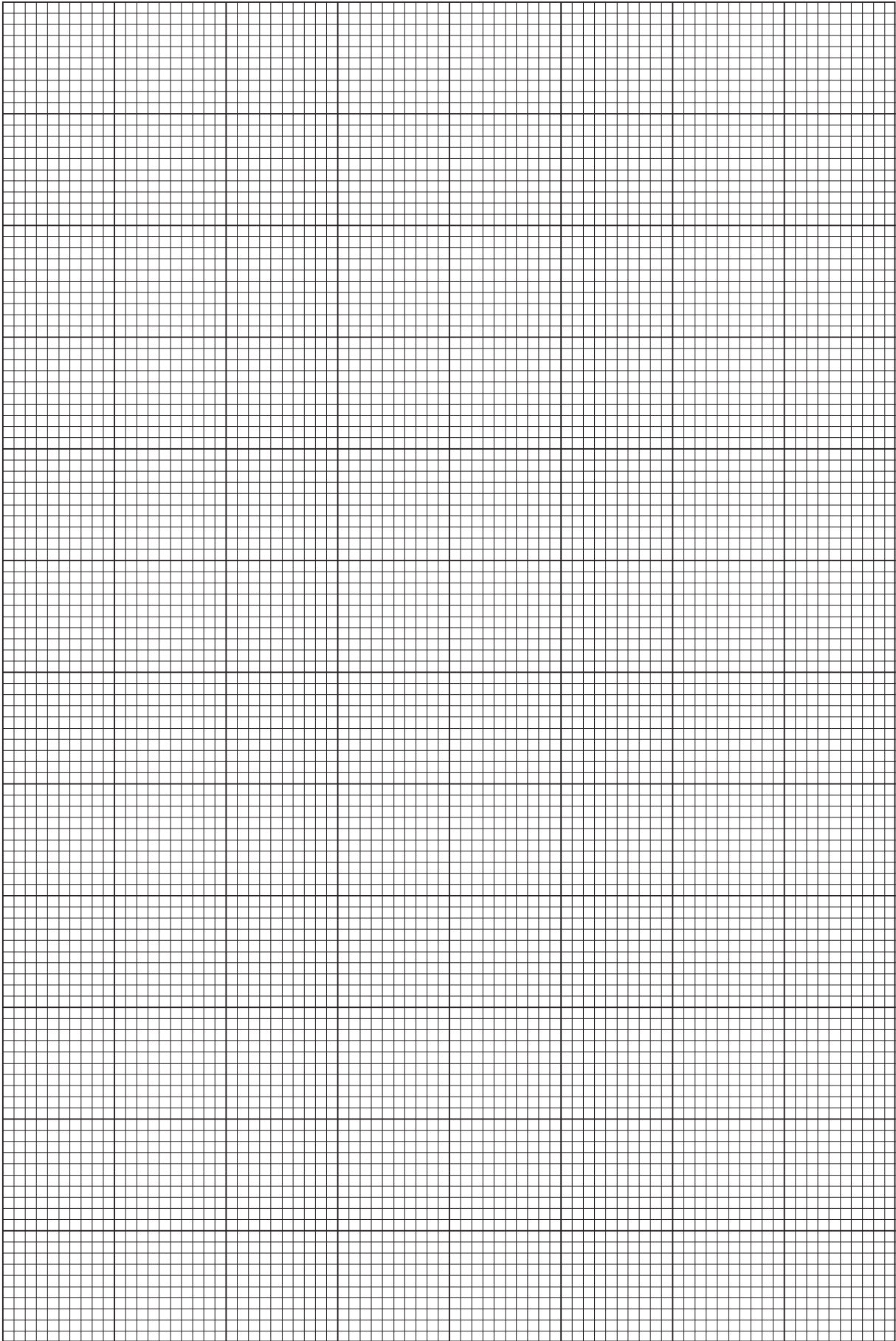

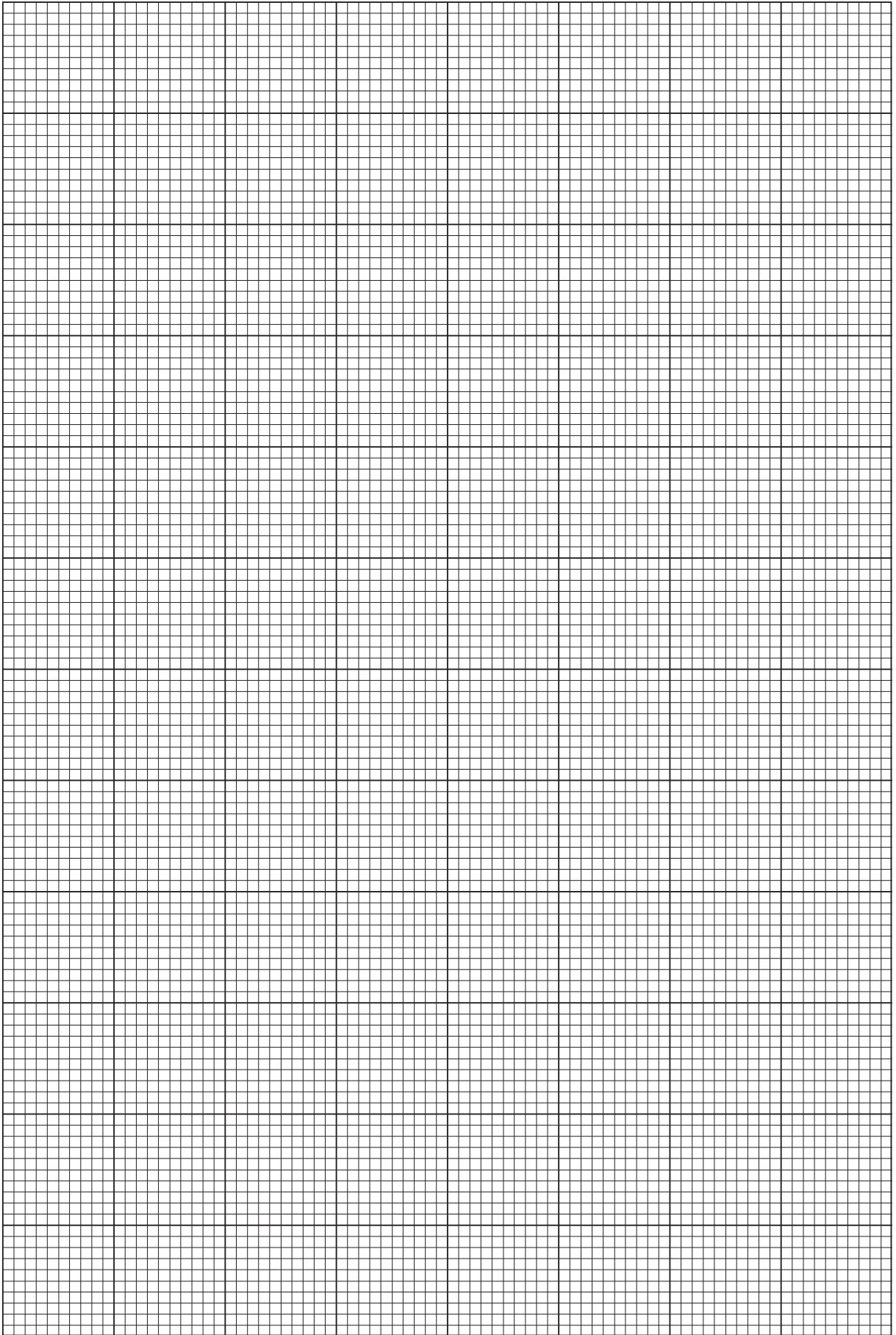

* X 8 5 7 7 5 0 1 4 5 *

ADDITIONAL SPACE FOR ANSWERS AND ROUGH WORK

Additional graph paper for use with question 2 (a) (i)

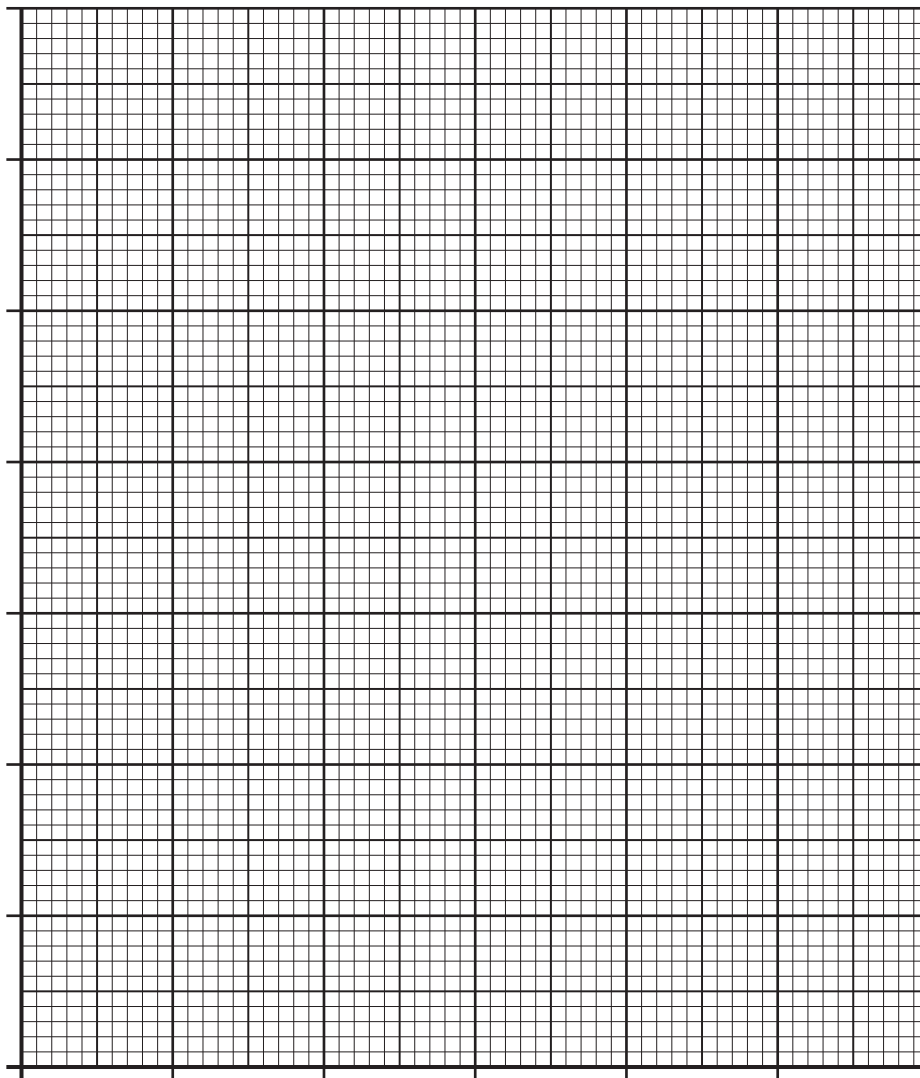

ADDITIONAL SPACE FOR ANSWERS AND ROUGH WORK

Additional diagram for use with question 3 (a) (ii)

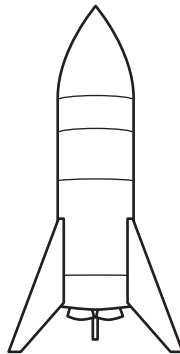

ADDITIONAL SPACE FOR ANSWERS AND ROUGH WORK

Additional diagram for use with question 7 (c) (i)

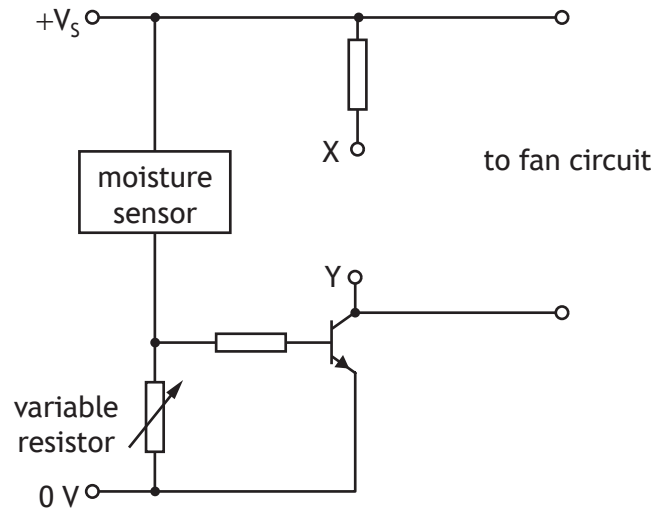

Additional diagram for use with question 10 (b)

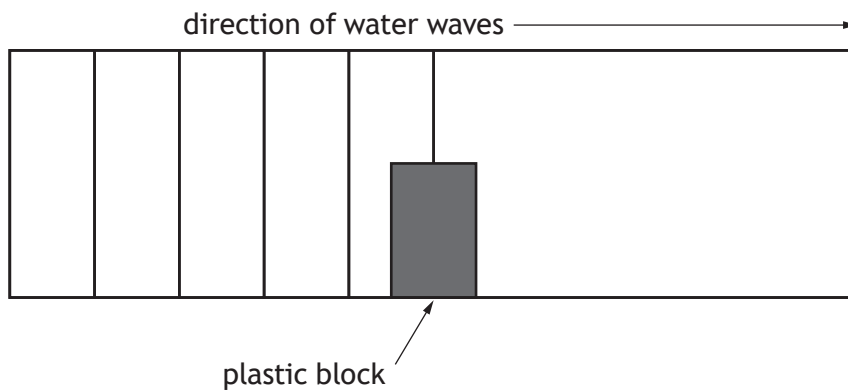

ADDITIONAL SPACE FOR ANSWERS AND ROUGH WORK

Additional diagram for use with question 11 (a) (ii)

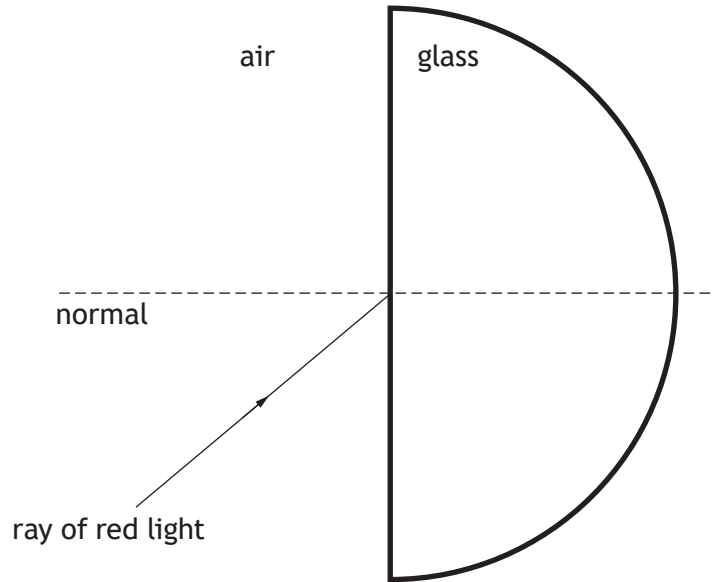

Additional graph for use with question 12 (a) (ii)

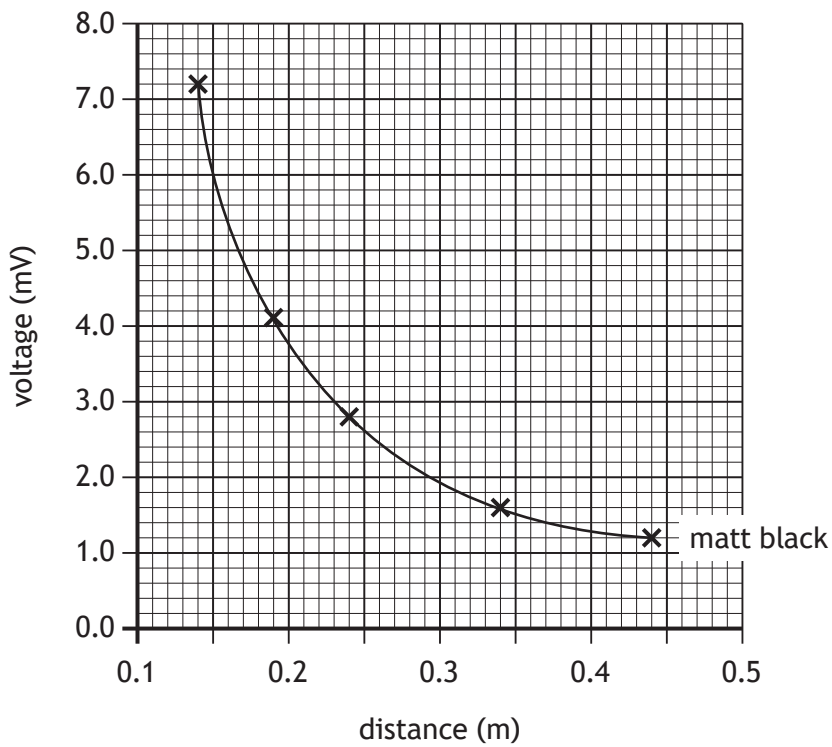

MARKS DO NOT
WRITE IN
THIS
MARGIN

ADDITIONAL SPACE FOR ANSWERS AND ROUGH WORK



* X 8 5 7 7 5 0 1 5 0 *

MARKS DO NOT
WRITE IN
THIS
MARGIN

ADDITIONAL SPACE FOR ANSWERS AND ROUGH WORK



* X 8 5 7 7 5 0 1 5 1 *

[BLANK PAGE]

DO NOT WRITE ON THIS PAGE

Acknowledgement of copyright

Question 3	R-Type/shutterstock.com
Question 4	S.Bachstroem/shutterstock.com
Question 5	ployy/shutterstock.com
Question 8	Maxx-Studio/shutterstock.com
Question 11 (b)	laremenko sergii/shutterstock.com
Question 13	Lightspruch/shutterstock.com
Question 14	LuYago/shutterstock.com



* X 8 5 7 7 5 0 1 5 2 *