

FOR OFFICIAL USE



National
Qualifications
2017

Mark

X757/75/01

**Physics
Section 1 — Answer Grid
And Section 2**

WEDNESDAY, 17 MAY

1:00 PM – 3:00 PM



* X 7 5 7 7 5 0 1 *

Fill in these boxes and read what is printed below.

Full name of centre

Town

Forename(s)

Surname

Number of seat

Date of birth

Day

Month

Year

Scottish candidate number

Total marks — 110

SECTION 1 — 20 marks

Attempt ALL questions.

Instructions for completion of Section 1 are given on *Page 02*.

SECTION 2 — 90 marks

Attempt ALL questions.

Reference may be made to the Data Sheet on *Page 02* of the question paper X757/75/02 and to the Relationship Sheet X757/75/11.

Write your answers clearly in the spaces provided in this booklet. Additional space for answers and rough work is provided at the end of this booklet. If you use this space you must clearly identify the question number you are attempting. Any rough work must be written in this booklet. You should score through your rough work when you have written your final copy.

Use **blue** or **black** ink.

Before leaving the examination room you must give this booklet to the Invigilator; if you do not, you may lose all the marks for this paper.



* X 7 5 7 7 5 0 1 0 1 *

The questions for Section 1 are contained in the question paper X757/75/02.

Read these and record your answers on the answer grid on *Page 03* opposite.

Use **blue** or **black** ink. Do NOT use gel pens or pencil.

1. The answer to each question is **either** A, B, C, D or E. Decide what your answer is, then fill in the appropriate bubble (see sample question below).
2. There is **only one correct** answer to each question.
3. Any rough work must be written in the additional space for answers and rough work at the end of this booklet.

Sample Question

The energy unit measured by the electricity meter in your home is the:

- A ampere
- B kilowatt-hour
- C watt
- D coulomb
- E volt.

The correct answer is **B** — kilowatt-hour. The answer **B** bubble has been clearly filled in (see below).

A	B	C	D	E
<input type="radio"/>	<input checked="" type="radio"/>	<input type="radio"/>	<input type="radio"/>	<input type="radio"/>

Changing an answer

If you decide to change your answer, cancel your first answer by putting a cross through it (see below) and fill in the answer you want. The answer below has been changed to **D**.

A	B	C	D	E
<input type="radio"/>	<input checked="" type="radio"/>	<input type="radio"/>	<input checked="" type="radio"/>	<input type="radio"/>

If you then decide to change back to an answer you have already scored out, put a tick (✓) to the **right** of the answer you want, as shown below:

A	B	C	D	E	or	A	B	C	D	E
<input type="radio"/>	<input checked="" type="radio"/>	<input type="radio"/>	<input checked="" type="radio"/>	<input type="radio"/>		<input type="radio"/>	<input checked="" type="radio"/>	<input type="radio"/>	<input type="radio"/>	<input type="radio"/>



SECTION 1 — Answer Grid



	A	B	C	D	E
1	<input type="radio"/>	<input type="radio"/>	<input type="radio"/>	<input type="radio"/>	<input type="radio"/>
2	<input type="radio"/>	<input type="radio"/>	<input type="radio"/>	<input type="radio"/>	<input type="radio"/>
3	<input type="radio"/>	<input type="radio"/>	<input type="radio"/>	<input type="radio"/>	<input type="radio"/>
4	<input type="radio"/>	<input type="radio"/>	<input type="radio"/>	<input type="radio"/>	<input type="radio"/>
5	<input type="radio"/>	<input type="radio"/>	<input type="radio"/>	<input type="radio"/>	<input type="radio"/>
6	<input type="radio"/>	<input type="radio"/>	<input type="radio"/>	<input type="radio"/>	<input type="radio"/>
7	<input type="radio"/>	<input type="radio"/>	<input type="radio"/>	<input type="radio"/>	<input type="radio"/>
8	<input type="radio"/>	<input type="radio"/>	<input type="radio"/>	<input type="radio"/>	<input type="radio"/>
9	<input type="radio"/>	<input type="radio"/>	<input type="radio"/>	<input type="radio"/>	<input type="radio"/>
10	<input type="radio"/>	<input type="radio"/>	<input type="radio"/>	<input type="radio"/>	<input type="radio"/>
11	<input type="radio"/>	<input type="radio"/>	<input type="radio"/>	<input type="radio"/>	<input type="radio"/>
12	<input type="radio"/>	<input type="radio"/>	<input type="radio"/>	<input type="radio"/>	<input type="radio"/>
13	<input type="radio"/>	<input type="radio"/>	<input type="radio"/>	<input type="radio"/>	<input type="radio"/>
14	<input type="radio"/>	<input type="radio"/>	<input type="radio"/>	<input type="radio"/>	<input type="radio"/>
15	<input type="radio"/>	<input type="radio"/>	<input type="radio"/>	<input type="radio"/>	<input type="radio"/>
16	<input type="radio"/>	<input type="radio"/>	<input type="radio"/>	<input type="radio"/>	<input type="radio"/>
17	<input type="radio"/>	<input type="radio"/>	<input type="radio"/>	<input type="radio"/>	<input type="radio"/>
18	<input type="radio"/>	<input type="radio"/>	<input type="radio"/>	<input type="radio"/>	<input type="radio"/>
19	<input type="radio"/>	<input type="radio"/>	<input type="radio"/>	<input type="radio"/>	<input type="radio"/>
20	<input type="radio"/>	<input type="radio"/>	<input type="radio"/>	<input type="radio"/>	<input type="radio"/>



[BLANK PAGE]

DO NOT WRITE ON THIS PAGE



* X 7 5 7 7 5 0 1 0 4 *

[Turn over for next question

DO NOT WRITE ON THIS PAGE



* X 7 5 7 7 5 0 1 0 5 *

SECTION 2 — 90 marks

Attempt ALL questions

1. The rating plate on a food blender is shown.

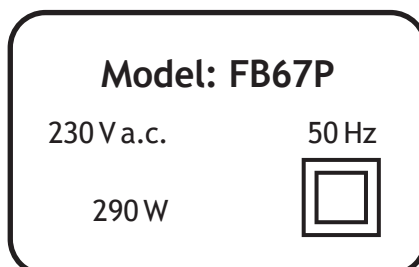

- (a) The plugs on all modern electrical appliances in the UK are fitted with fuses rated at either 3 A or 13 A.

(i) Draw the circuit symbol for a fuse.

1

(ii) State the purpose of the fuse fitted in the plug of an appliance.

1

(iii) Determine the rating of the fuse fitted in the plug of the blender.
Justify your answer by calculation.

4

Space for working and answer



* X 7 5 7 7 5 0 1 0 6 *

MARKS

DO NOT
WRITE IN
THIS
MARGIN

1. (continued)

(b) The blender is connected to an alternating current (a.c.) supply.

Explain in terms of electron flow what is meant by *alternating current*.

1



* X 7 5 7 7 5 0 1 0 7 *

2. A student sets up the following circuit.

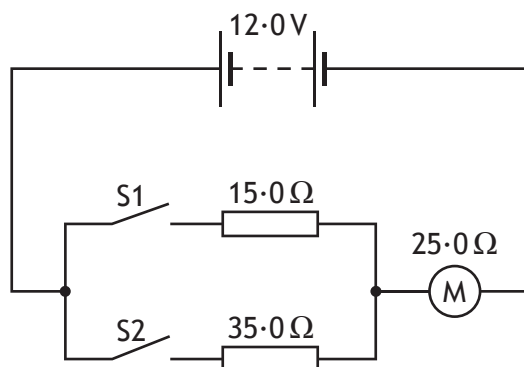

(a) The student closes switch S1.

(i) Calculate the voltage across the motor.

4

Space for working and answer

(ii) Calculate the power dissipated in the motor.

3

Space for working and answer



* X 7 5 7 7 5 0 1 0 8 *

MARKS

DO NOT
WRITE IN
THIS
MARGIN

2. (continued)

(b) The student now also closes switch S2.

(i) Calculate the combined resistance of the two resistors.

3

Space for working and answer

(ii) State the effect that closing switch S2 has on the power dissipated in the motor.

3

Justify your answer.



* X 7 5 7 7 5 0 1 0 9 *

3. A bicycle pump with a sealed outlet contains $4.0 \times 10^{-4} \text{ m}^3$ of air. The air inside the pump is at an initial pressure of $1.0 \times 10^5 \text{ Pa}$. The piston of the pump is now pushed slowly inwards until the volume of air in the pump is $1.6 \times 10^{-4} \text{ m}^3$ as shown.

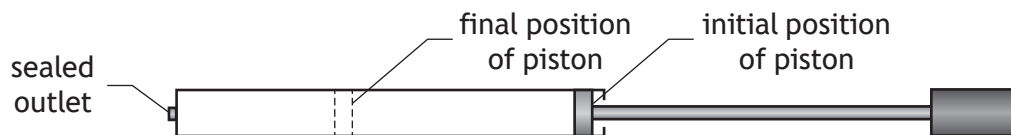

During this time the temperature of the air in the pump remains constant.

- (a) Calculate the final pressure of the air inside the pump.

3

Space for working and answer

- (b) Using the kinetic model, explain what happens to the pressure of the air inside the pump as its volume decreases.

3



* X 7 5 7 7 5 0 1 1 0 *

3. (continued)

- (c) The piston is now released, allowing it to move outwards towards its original position.

During this time the temperature of the air in the pump remains constant.

Using the axes provided, sketch a graph to show how the pressure of the air in the pump varies as its volume increases.

Numerical values are not required on either axis.

(An additional diagram, if required, can be found on *Page 28*)

2



4. A student observes water waves entering a harbour.

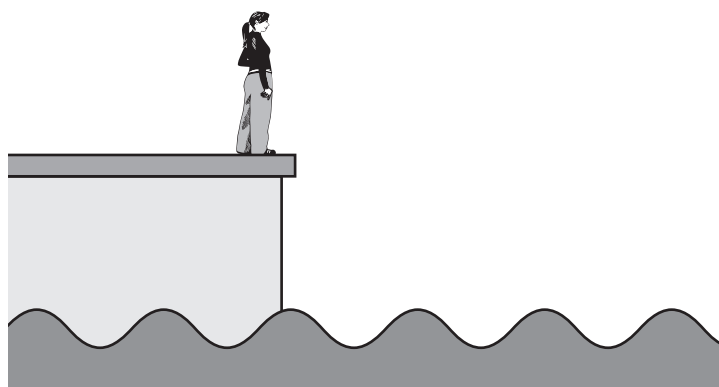

(a) To determine the frequency of the waves, the student measures the time taken for a wave to pass a point at the harbour entrance.

The student measures this time to be 2.5 s

(i) Calculate the frequency of the waves.

3

Space for working and answer

(ii) Suggest how the accuracy of the frequency determined by the student could be improved.

1



* X 7 5 7 7 5 0 1 1 2 *

4. (continued)

MARKS

DO NOT
WRITE IN
THIS
MARGIN

- (b) The distance between one wave crest and the next crest is 8.0 m.
Calculate the velocity of the waves.
Space for working and answer

3

- (c) Waves travel towards the entrance of the harbour as shown.

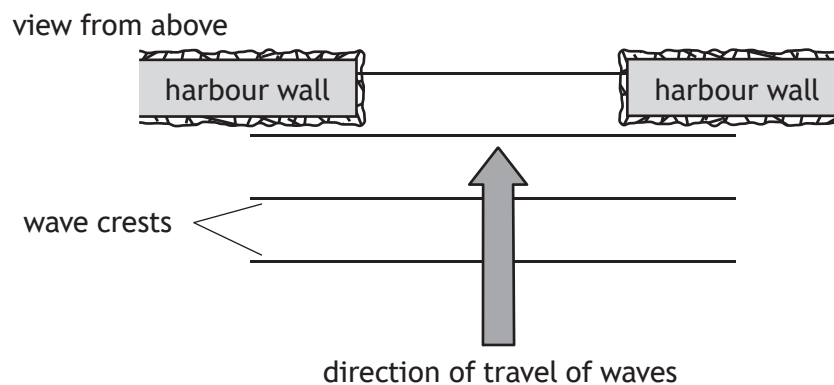

Complete the diagram to show the pattern of wave crests inside the harbour.

2

(An additional diagram, if required, can be found on *Page 28*)

- (d) As the waves pass into the harbour the student observes that the amplitude of the waves decreases.
Explain this observation.

1



[BLANK PAGE]

DO NOT WRITE ON THIS PAGE



* X 7 5 7 7 5 0 1 1 4 *

MARKS

DO NOT
WRITE IN
THIS
MARGIN

5. Alpha, beta and gamma are types of nuclear radiation, which have a range of properties and effects.

Using your knowledge of physics, comment on the similarities and/or differences between these types of nuclear radiation.

3



* X 7 5 7 7 5 0 1 1 5 *

6. A technician uses the apparatus shown to investigate the effect of shielding gamma radiation with lead.

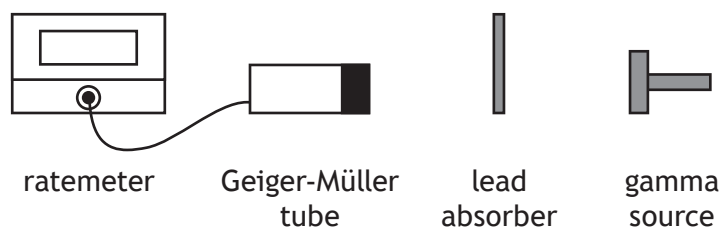

Gamma radiation passing through a lead absorber is detected by a Geiger-Müller tube. The count rate is displayed on the ratemeter.

The count rates for a range of different thicknesses of lead absorber are recorded.

Using these results the technician produces a graph of corrected count rate against thickness of lead absorber as shown.

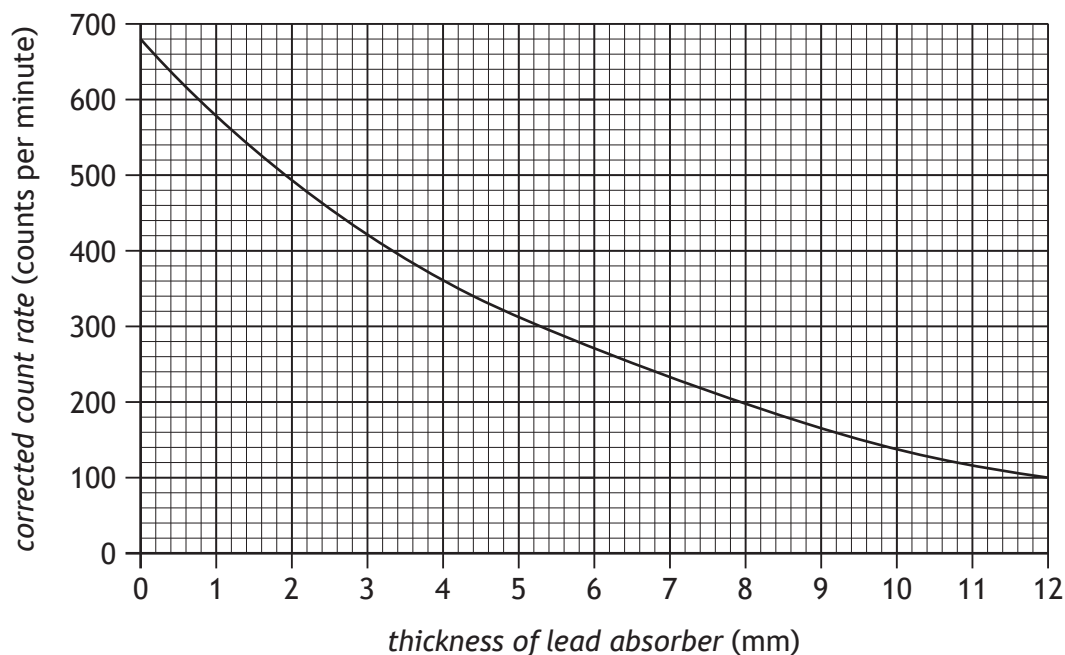

- (a) State what additional measurement the technician must have made in order to determine the corrected count rate.

1



6. (continued)

(b) The half-value thickness of a material is the thickness of material required to reduce the corrected count rate from a source by half.

(i) Using the graph, determine the half-value thickness of lead for this source of gamma radiation.

1

(ii) Determine the thickness of lead required to reduce the corrected count rate to one eighth of its initial value.

2

Space for working and answer

(iii) The technician suggests repeating the experiment with aluminium absorbers instead of lead absorbers.

Predict how the half-value thickness of aluminium would compare to the half-value thickness of lead for this source.

1

(c) When working with the radioactive source the technician is exposed to an equivalent dose rate of $2.5 \times 10^{-6} \text{ Sv h}^{-1}$.

The annual equivalent dose limit for the technician is 20 mSv.

Calculate the maximum number of hours the technician may work with this source without exceeding this limit.

3

Space for working and answer



* X 7 5 7 7 5 0 1 1 7 *

7. Nuclear reactions are used to generate electrical energy in a nuclear power station.



- (a) The fuel for the power station is in the form of pellets, containing uranium-235.

A fuel pellet has an activity of 80 kBq.

State what is meant by an *activity of 80 kBq*.

1

- (b) In a nuclear reaction a uranium-235 nucleus is split by a neutron to produce two smaller nuclei, three neutrons, and energy.

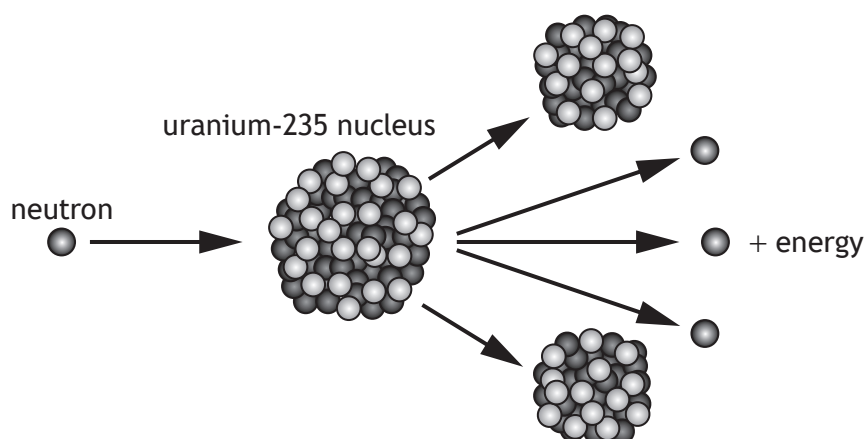

7. (b) (continued)

(i) Explain how a single reaction can lead to the continuous generation of energy.

2

(ii) One nuclear reaction releases 3.2×10^{-11} J.

In the reactor, 3.0×10^{21} reactions occur each minute.

Determine the maximum power output of the reactor.

Space for working and answer

4

(c) The nuclear reactor produces waste that emits nuclear radiation.

State a use of nuclear radiation.

1



* X 7 5 7 7 5 0 1 1 9 *

8. In speedway, motorbikes are raced anticlockwise round an oval track.



A race consists of four laps of a 380 m track.

(a) State the displacement of a motorbike from the start line to the finish line for a complete race.

1

(b) The speed-time graph of a motorbike for the first 8.0s of a race is shown.

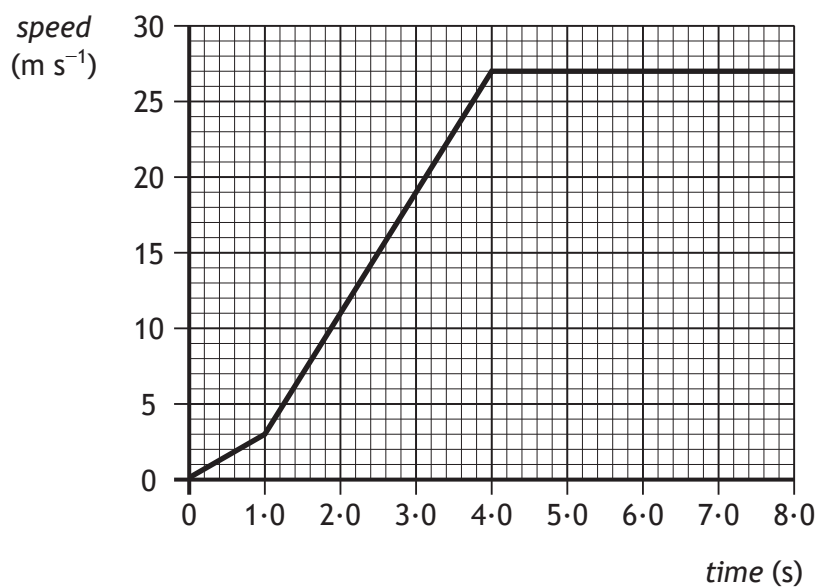

8. (b) (continued)

- (i) Calculate the distance travelled by the motorbike in the first 4.0 s of the race.

3

Space for working and answer

- (ii) Determine the **greatest** acceleration of the motorbike during the first 8.0 s of the race.

3

Space for working and answer

- (c) The winner of the race completes all four laps in a time of 79 s. Calculate the average speed of the winner.

3

Space for working and answer



* X 7 5 7 7 5 0 1 2 1 *

9. A weightlifter applies an upwards force of 1176 N to a barbell to hold it in a stationary position as shown.



- (a) Describe how the upward force exerted by the weightlifter on the barbell compares to the weight of the barbell. 1
- (b) Calculate the mass of the barbell. 3
Space for working and answer
- (c) The weightlifter increases the upward force on the barbell to 1344 N in order to lift the barbell above their head. 4
 Calculate the initial acceleration of the barbell.
Space for working and answer



10. An articulated lorry has six pairs of wheels.
One pair of wheels can be raised off the ground.

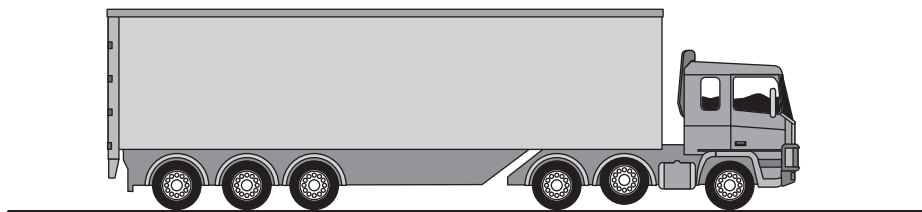

Using your knowledge of physics, comment on situations in which the wheels may be raised or lowered.

3



* X 7 5 7 7 5 0 1 2 3 *

11. A tennis player serves a tennis ball horizontally at a velocity of 42 ms^{-1} .

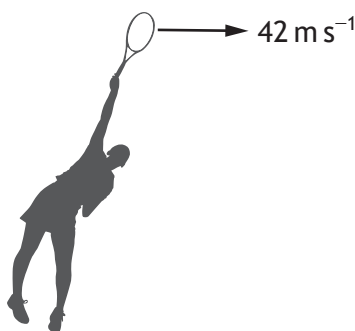

The effects of air resistance are negligible.

(a) State which of the following graphs P, Q or R shows the vertical velocity of the ball after it leaves the player's racquet.

1

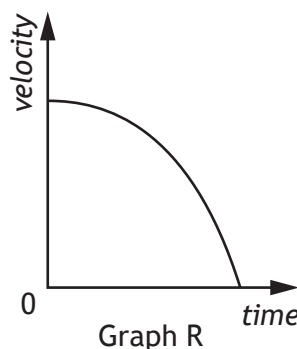
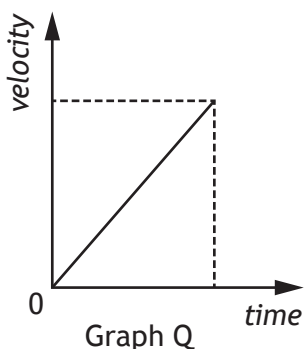
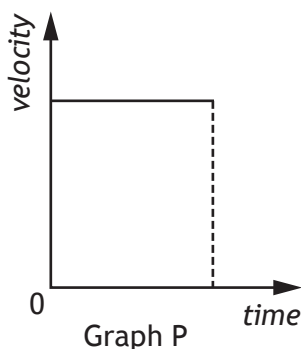

Graph: _____

(b) In a second serve the player hits the ball horizontally with a smaller velocity from the same height.

State whether the time taken for the ball to reach the ground is less than, equal to, or greater than the time taken in the first serve.

Justify your answer.

2



11. (continued)

- (c) The tennis court has a retractable roof to allow play to continue in all weather conditions.

It requires 5.5 kJ of energy to move one section of the roof a distance of 25 m.

Calculate the average force acting on this section of the roof while it is being moved.

3

Space for working and answer



* X 7 5 7 7 5 0 1 2 5 *

12. The star Wolf 359 is at a distance of 7.8 light-years from Earth.
A radio signal from Wolf 359 is detected by a radio telescope on Earth.



- (a) (i) State the speed of the radio waves. 1
- (ii) Calculate the distance, in metres, from Wolf 359 to Earth. 3
Space for working and answer
- (b) Another telescope is used to observe the same star in the visible part of the spectrum.
- (i) State a suitable detector of visible light that may be used in this telescope. 1
- (ii) State whether the time taken for the visible light from the star to reach Earth is less than, equal to, or greater than the time taken for the radio waves from the star to reach Earth. 1

[END OF QUESTION PAPER]



* X 7 5 7 7 5 0 1 2 6 *

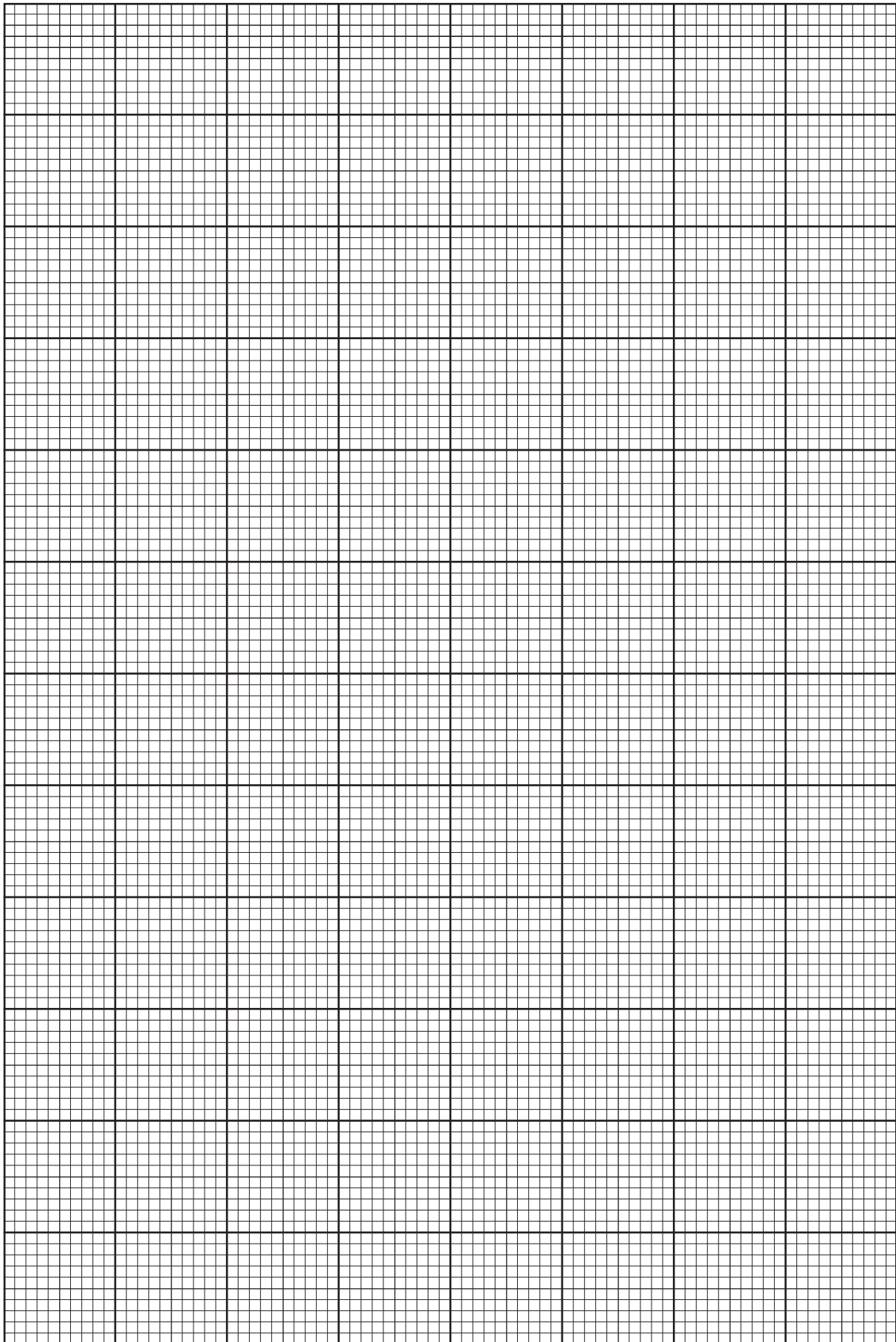

* X 7 5 7 7 5 0 1 2 7 *

ADDITIONAL SPACE FOR ANSWERS AND ROUGH WORKING

Additional diagram for Q3 (c)



Additional diagram for Q4 (c)

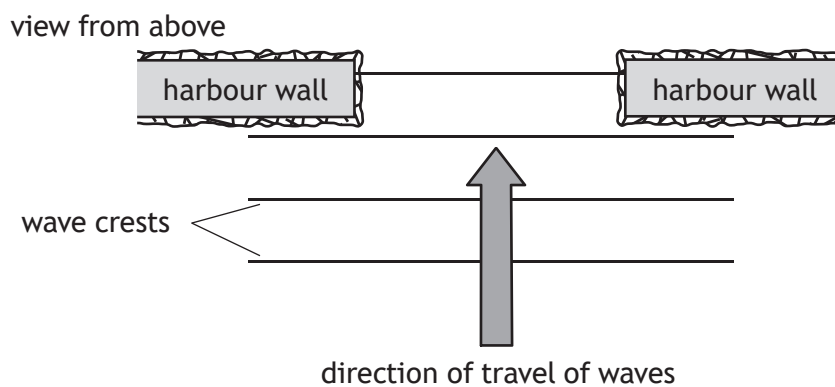

* X 7 5 7 7 5 0 1 2 8 *

MARKS

DO NOT
WRITE IN
THIS
MARGIN

ADDITIONAL SPACE FOR ANSWERS AND ROUGH WORKING



* X 7 5 7 7 5 0 1 2 9 *

MARKS

DO NOT
WRITE IN
THIS
MARGIN

ADDITIONAL SPACE FOR ANSWERS AND ROUGH WORKING



* X 7 5 7 7 5 0 1 3 0 *

[BLANK PAGE]

DO NOT WRITE ON THIS PAGE



* X 7 5 7 7 5 0 1 3 1 *

[BLANK PAGE]

DO NOT WRITE ON THIS PAGE

Acknowledgement of Copyright

Question 7 Michael Schneidmiller/shutterstock.com

Question 9 Ljupco Smokovski/shutterstock.com

Question 12 kojihirano/shutterstock.com



* X 7 5 7 7 5 0 1 3 2 *