

N5

National 5
Coursework
Assessment Task



National 5 Graphic Communication Assignment Assessment task

Valid for session 2022-23 only.

This assessment is given to centres in strictest confidence. You must keep it in a secure place until it is used.

This edition: December 2022 (version 1.1)

© Scottish Qualifications Authority 2022

Contents

Introduction	1
Instructions for teachers and lecturers	2
Instructions for candidates	5

Introduction

This document contains instructions for teachers and lecturers and instructions for candidates for the National 5 Graphic Communication assignment.

This is one of two course assessment components. The other component is a question paper.

To support teachers, lecturers and candidates, the modifications to the assignment that were in place for session 2021-22, which we reiterate below, remain in place for session 2022-23.

We have published the assignment in December 2022 rather than at the end of January 2023.

The uplift date for the National 5 assignment is the same as Higher.

Existing assessment conditions (the assignment must be conducted under a high degree of supervision and control) remain in place, with the additional guidance from last session:

- ◆ Candidates can work on the assignment at home if necessary – for example, if a centre is temporarily closed. Where possible, adhere to the published conditions of assessment to maintain the reliability and validity of the evidence generated.
- ◆ Candidates can spend additional time on the assignment if necessary – for example, if a centre is temporarily closed. Use professional judgement to decide if additional time is necessary, as the assignment is designed to be completed in 8 hours. Spending more time on it could affect candidates' ability to cover all the learning required for the course and prepare for the question paper.

Instructions for teachers and lecturers

You must conduct the assignment under a high degree of supervision and control. This means:

- ◆ candidates must be within your direct sight
- ◆ candidates must not interact with each other
- ◆ candidates must not have access to e-mail, the internet and mobile phones
- ◆ candidates must complete their work independently – no group work is permitted
- ◆ classroom display materials that might provide assistance must be removed or covered
- ◆ with no interruption for learning and teaching
- ◆ in a classroom environment

Time

Candidates have 8 hours to complete the assignment, starting at an appropriate point in the course after all content has been delivered. Once candidates begin, they must continue in each subsequent class period until the permitted time allocation has been used up.

You have a responsibility to manage candidates' work, distributing it at the beginning and collecting it at the end of each session, and storing it securely in-between. This activity does not count towards the total time permitted for candidates to complete the assignment.

Resources

This is a closed-book assessment. Candidates must not have access to learning and teaching materials, the internet, notes, exemplar materials, resources on classroom walls or anything similar.

There may be instances where restriction of internet and/or network use is prohibited (for example, if you have a local authority-managed network with specific limitations or CAD software that is web-based). However, it remains your professional responsibility to make every effort to meet the assessment conditions.

Each assessment task includes instructions and details of any equipment or materials required. Candidates can also use normal classroom equipment, software and hardware (such as drawing instruments, CAD and DTP software, and PCs to run the software) to complete the tasks.

Reasonable assistance

Candidates must progress through each stage of the assignment without your intervention or guidance, having acquired the skills earlier in the course.

Once candidates complete the assignment, you must not return it to them for further work. You must not provide feedback to candidates or offer an opinion on the perceived quality or completeness of the assignment response, at any stage.

You can provide reasonable assistance to support candidates with the following aspects of their assignment:

- ◆ printing, collating, stapling and labelling their evidence to ensure it is in the format specified by SQA
- ◆ ensuring candidates have all the materials and equipment required to complete the assignment
- ◆ understanding the information outlined in these instructions

Evidence

All candidate evidence (whether created manually or electronically) must be submitted to SQA in paper-based format.

Each task details what evidence is required and how many pages are expected. This is a guide to ensure that candidates do not produce too much work or spend too long on a single task. Single-sided A3 pages are preferred and are typically the most suitable for the tasks; however, it is acceptable to submit A4 pages if an A3 printer is not available.

Each piece of work must be labelled with the task number, for example, task 1a, and the back of each page must be clearly labelled with candidate details.

Alteration or adaptation

You must not alter, adapt or modify the assignment in any way. This includes moving the content of the assignment into a different format or workbook. All candidates must undertake the assignment exactly as it is provided.

Volume

Candidates should present their work on a maximum of eight single-sided A3 pages.

This figure is given to indicate the volume of evidence required; however, no penalty is applied where candidates exceed this. Full details of evidence requirements are contained within each assessment task.

Specific instructions for teachers and lecturers

You must follow these specific instructions. You must ensure that candidates are aware of the assessment conditions and know what they should do for each task.

Prior to candidates starting the assignment, you must download the following electronic files for their use. You must keep these files secure and candidates must not access them prior to assessment.

- ◆ Data sheet 2a - Bon Abode Logo (available as both svg and png).
- ◆ Data sheet 2b - images 1 - 15 (images 14 and 15 are available as both svg and png).

This assignment has three tasks, all of which are mandatory. Candidates must complete the tasks in order.

Each task has a notional time allocated to it. This is not mandatory and is an indication of how long candidates should spend on the task.

Task 1 – 13 marks: producing production drawings for a desk lamp.
(suggested time 2-3 hours)

- ◆ Task 1: candidates must produce their production drawings electronically and generate them from a 3D CAD model.

Task 2 – 11 marks: producing promotional and preliminary graphics for a desk lamp.
(suggested time 2 hours)

- ◆ Task 2a: candidates must complete this electronically.
- ◆ Task 2b: candidates can complete this manually or electronically.
- ◆ Task 2b: candidates must identify where they have used **depth** - there is no requirement for candidates to identify the use of any other design elements/principles at task 2b.
- ◆ Task 2c: candidates must complete this electronically.
- ◆ Task 2c: candidates must fully annotate and give justification for two DTP elements and principles other than **depth**.

Task 3 – 16 marks: producing preliminary graphics for a desk clock.
(suggested time 2-3 hours)

- ◆ Tasks 3a, 3b and 3c: Candidates are expected to complete this task manually. If they use an electronic method, it must not be 3D CAD software. Candidates will gain no marks if this software is used. If candidates use electronic sketching software, they are only permitted to use a straight edge. No other tools are permitted.

Note: candidates must not trace drawings for any part of the assignment. They will gain no marks for traced drawings.

All electronically generated evidence must be printed and compiled for uplift by SQA.

Instructions for candidates

This assessment applies to the assignment for National 5 Graphic Communication.

It assesses the following skills, knowledge and understanding:

- ◆ demonstrating graphic design skills and creativity
- ◆ using graphic communication technologies
- ◆ producing preliminary, production and promotional graphic items in response to a situation or problem
- ◆ using illustration techniques to create graphics with relevant visual impact
- ◆ producing 2D and 3D production drawings, applying appropriate standards, protocols and conventions (drawing includes manual or electronic production methodologies)
- ◆ reviewing and evaluating your progress, giving justification for your choice of graphic items and the graphic communication techniques employed

This is a closed-booked assessment. Your teacher or lecturer will let you know if there are any specific conditions for doing this assessment.

Read all of the questions in each task before starting.

Note: you must not trace drawings for any part of the assignment. You will gain no marks for traced drawings.

In this assessment, you have to:

- ◆ produce a range of graphics in response to a series of tasks, which will test aspects of the skills and knowledge listed above
- ◆ complete all of the tasks in the order presented

You have 8 hours to complete the assignment, excluding the time required to set up and clear away any equipment you need, and for any printing that is required.

You must not use any text, images, or other items from any other source unless you created them during this 8-hour assignment.

The assignment has three tasks, with marks allocated as follows:

Task 1 – 13 marks: producing production drawings for a desk lamp.
(suggested time 2-3 hours)

Task 2 – 11 marks: producing promotional and preliminary graphics for a desk lamp. This includes a CAD-rendered desk lamp and work for packaging for the desk lamp.
(suggested time 2 hours)

Task 3 – 16 marks: producing preliminary graphics for a desk clock.
(suggested time 2-3 hours)

You should complete this task manually. If you use an electronic method, it must not be 3D CAD software, you will gain no marks if this is used. If you use electronic sketching software, you are only permitted to use a straight edge. No other tools are permitted.

Your teacher or lecturer will provide you with:

- ◆ task sheets 1 to 3
- ◆ data sheets 1a to 3c
- ◆ electronic files for task 2

Assessment conditions

This is a closed-book assessment. You must undertake the assignment under a high degree of supervision and control. This means:

- ◆ you must be within direct sight of your teacher or lecturer
- ◆ you must not interact with other candidates
- ◆ you must not have access to email, the internet and mobile phones
- ◆ you must complete your work independently – no group work is permitted

You have 8 hours to complete the assignment. Once you begin, you must continue in each subsequent class period until the permitted time allocation has been used up.

Reasonable assistance

You must progress through each stage of the assignment without intervention or guidance from your teacher or lecturer.

Once you have completed the assignment, it will not be returned to you for further work. You will not be provided with feedback on the perceived quality or completeness of the assignment response at any stage.

You can be provided reasonable assistance to support with the following aspects of your assignment:

- ◆ printing, collating, stapling and labelling your evidence to ensure it is in the format specified by SQA
- ◆ ensuring you have all the materials and equipment required to complete the assignment
- ◆ understanding the information outlined in these instructions

Submitting your work

You must label each piece of evidence with the task number (for example task 1a), and the back of each page must be clearly labelled with your:

- ◆ name
- ◆ date of birth
- ◆ Scottish Candidate Number (SCN)
- ◆ centre name
- ◆ centre number

Task 1: desk lamp

A home accessories company is planning to launch a new desk lamp.

Using the information shown on data sheets 1a, 1b, 1c, 1d and 1e, model and assemble the desk lamp components using 3D CAD software. From these models, produce production drawings that will allow the desk lamp to be manufactured.

1a Produce suitable component orthographic views of the five parts of the desk lamp.

You must produce an elevation and a plan for each of the following parts:

- ◆ the base
- ◆ the fixing nut
- ◆ the toggle switch
- ◆ the shade
- ◆ the stem

You must:

- ◆ use third-angle projection
- ◆ **show all** hidden detail
- ◆ produce the views in the same orientation as the data sheets
- ◆ use appropriate dimensioning, annotations and a suitable scale.

(6 marks)

1b Produce a plan, sectional elevation and end elevation of the assembled desk lamp to a suitable scale.

The sectional elevation must cut through the centre of all five components.

You must:

- ◆ use third-angle projection
- ◆ produce the views as line drawings
- ◆ produce the views in the same orientation as data sheet 1e
- ◆ **not** show hidden detail.

(3 marks)

1c Produce an exploded isometric view of the desk lamp.

You must:

- ◆ produce the view as a line drawing
- ◆ produce the view in the same orientation as shown on data sheet 1a for the desk lamp assembly
- ◆ **not** show hidden detail
- ◆ **not** render the view.

(2 marks)

1d Include correct British Standard conventions and line types on all of your drawings.

(2 marks)

Note: you must create the production drawings for task 1 electronically and print them out. You should complete task 1 on a maximum of two or three single-sided A3-sized pages.

You should spend approximately 2 - 3 hours on task 1.

Your completed assignment (tasks 1 to 3) should be on no more than eight single-sided A3-sized pages.

Task 2: desk lamp

The home accessories company would like to you to produce the layout for the top panel of the desk lamp packaging.

For this task, your teacher or lecturer will provide you with the electronic files of the graphics shown on data sheets 2a and 2b.

You **must**:

- ◆ use the logo provided. You can use the logo as it is, or you can edit the colour to suit your design
- ◆ use the title provided
- ◆ use at least **one** of the images provided. You can use the images as they are, or you can edit them to suit your design
- ◆ **not** use any text, images or other item from any other source, unless you created them during this 8-hour assignment

Using the information on data sheets 2a and 2b, produce the following preliminary and promotional graphics.

- 2a Produce a CAD-rendered pictorial illustration of the assembled desk lamp you modelled in task 1, complete with appropriate materials, highlights and shadows.

You must use the following materials when producing your CAD render:

- ◆ the base – concrete (or wood if concrete is not available in the software you use)
- ◆ the fixing nut – metal
- ◆ the toggle switch – metal
- ◆ the shade – concrete (or wood if concrete is not available in the software you use)
- ◆ the stem – wood

(1 mark)

- 2b Produce two preliminary layouts/thumbnails of the top panel of the desk lamp packaging.

Your preliminary layouts/thumbnails must include the design principle of **depth** and at least **two** other design elements and principles. You must identify where you have used **depth** in **both** layouts/thumbnails.

Your layouts/thumbnails must also contain:

- ◆ the logo
- ◆ the title
- ◆ at least one of the images provided

You may use either manual or electronic methods to complete this task.

(2 marks)

2c Produce a final version of the promotional graphic, with high visual impact, for the top panel of the desk lamp. You must use the dimensions given on Data Sheet 2a for the panel.

The final version of the promotional graphic should be developed from your preliminary layouts/thumbnails, complete with:

- ◆ the logo
- ◆ the title
- ◆ your chosen image or images

You must annotate this layout referring to **two** design elements and principles you have used (**other than depth**) and describe their effect on the layout.

(8 marks)

Note: you should complete task 2 on a maximum of two or three single-sided sheets of A3-sized pages.

You should spend approximately 2 hours on task 2.

Your completed assignment (tasks 1 to 3) should be on no more than eight single-sided A3-sized pages

Task 3: desk clock

The home accessories company is developing a desk clock as part of their product range.

Using the drawings shown on data sheets 3a, 3b and 3c, produce preliminary sketches for the desk clock.

This task assesses your sketching skills. Do not use a drawing board. If you measure, trace or use any drawing instruments other than a straight edge, you will gain no marks for this task.

You should complete this task manually. If you use an electronic method, it must not be 3D CAD software, you will gain no marks if this is used. If you use electronic sketching software, you are only permitted to use a straight edge. No other tools are permitted.

- 3a Produce preliminary orthographic sketches of the elevation, end elevation and plan for each part of the desk clock.

Your sketches should be complete with enough information and dimensions to enable the component parts of the clock to be modelled using 3D CAD software.

You must:

- ◆ sketch the elevation of each of the component parts of the clock from the direction indicated on data sheets 3a, 3b and 3c
- ◆ use third-angle projection
- ◆ **show all** hidden detail.

(7 marks)

- 3b Produce preliminary orthographic sketches of the elevation, end elevation and plan of the assembled component parts of the clock.

You must:

- ◆ sketch the elevation of the assembled clock from the direction indicated on data sheet 3a
- ◆ use third-angle projection
- ◆ **not** show hidden detail

(4 marks)

- 3c Produce a rendered pictorial sketch of the assembled clock, showing appropriate colour, highlights, shadows and materials.

The parts of the clock must be made from the following materials:

- ◆ Clock Base – plastic
- ◆ Clock Stand – wood
- ◆ Clock Top – plastic

Do not show hidden detail.

(5 marks)

Note: you should complete task 3 on a maximum of two or three single-sided sheets of A3-sized pages.

You should spend approximately 2-3 hours on task 3.

Your completed assignment (tasks 1 to 3) should be on no more than eight single-sided A3-sized pages.

Data sheet 1a

Base

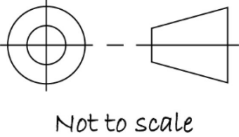
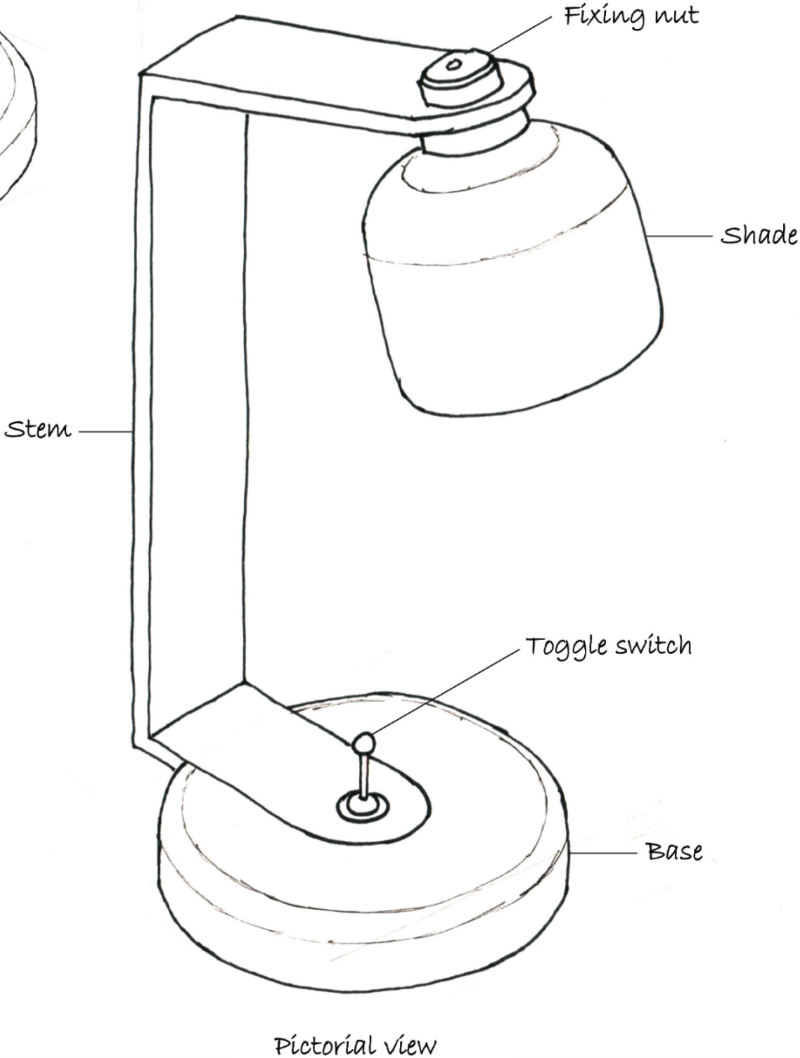
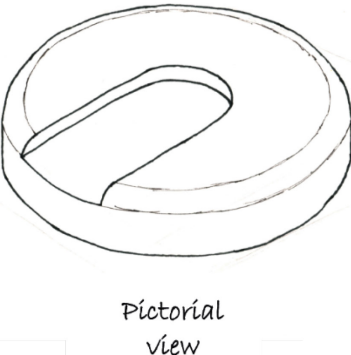
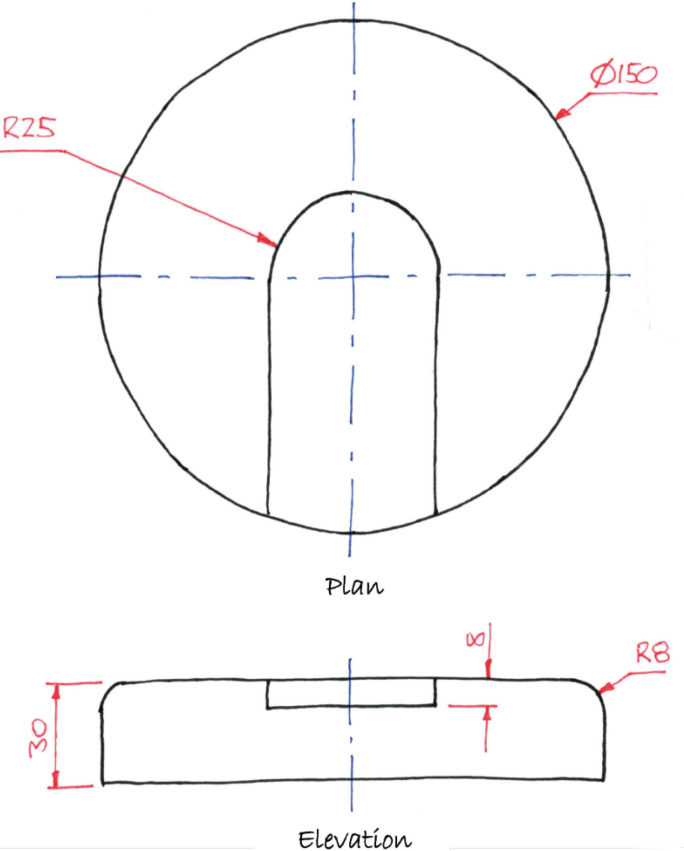

Data sheet 1b

Fixing nut

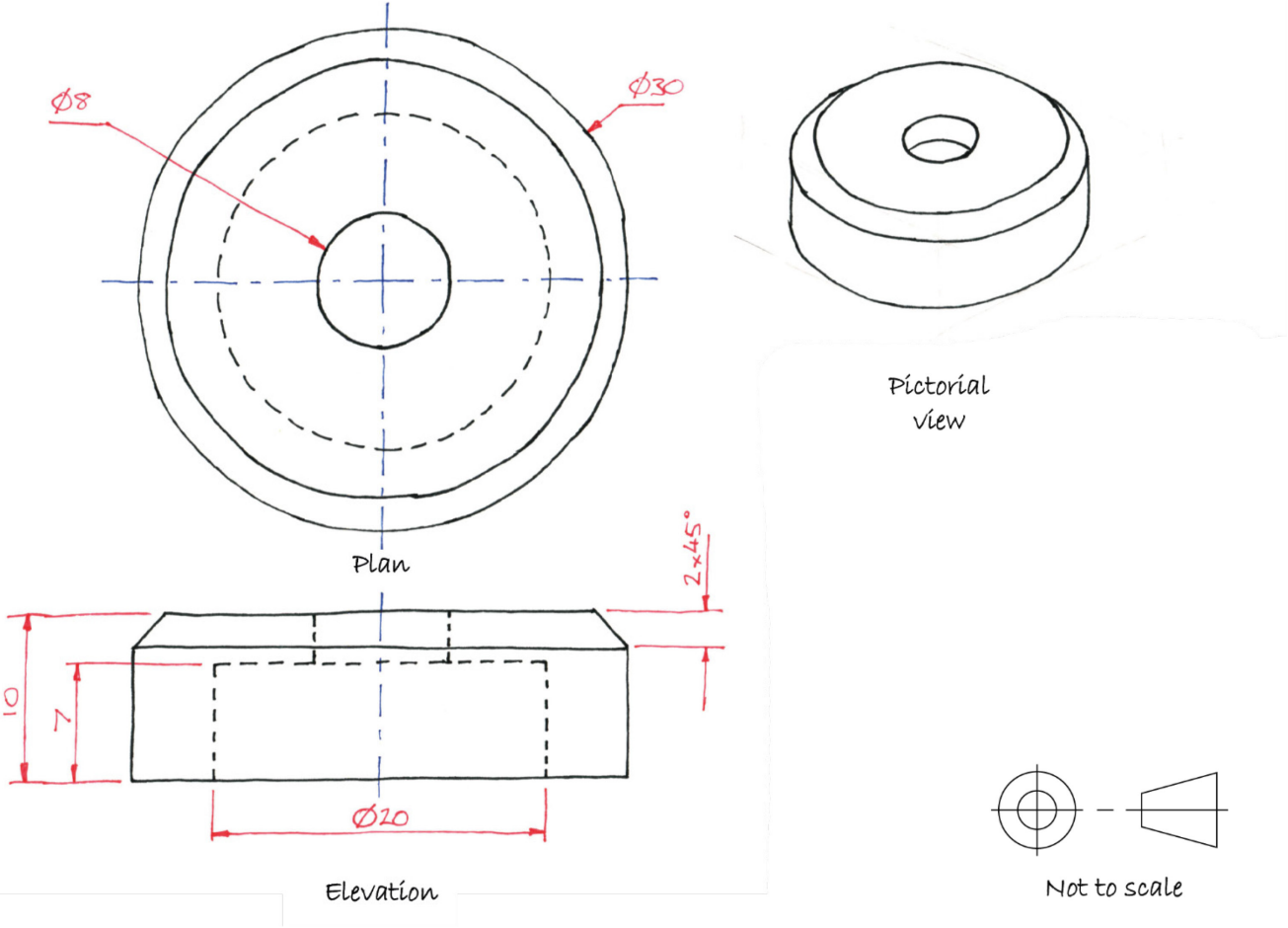

Data sheet 1c

Toggle switch

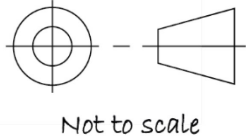
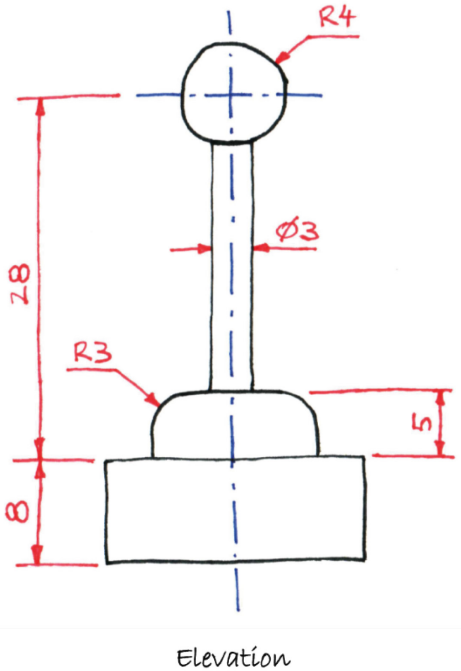
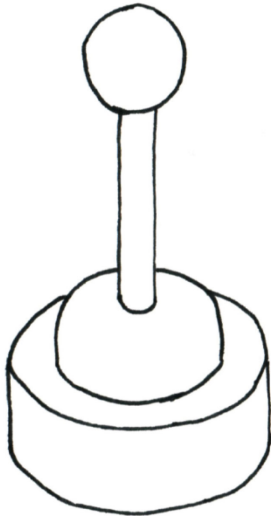
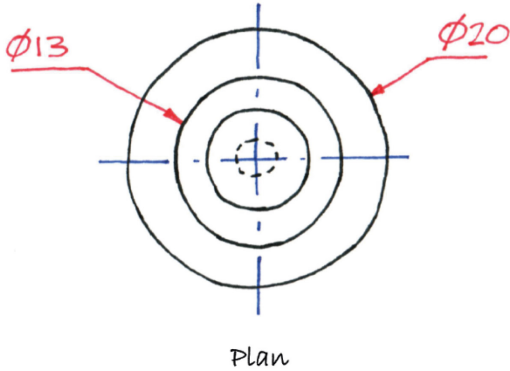

Data sheet 1d

Shade

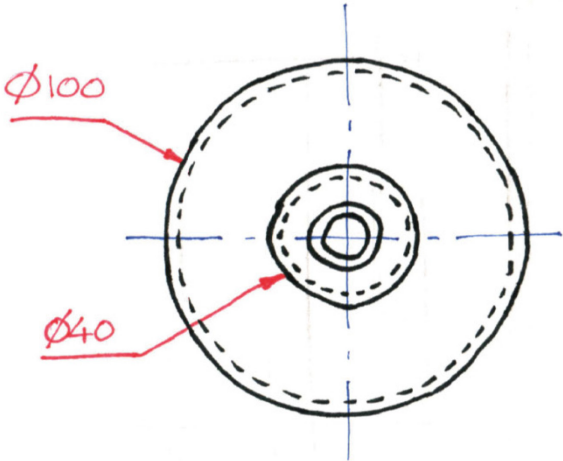

Plan

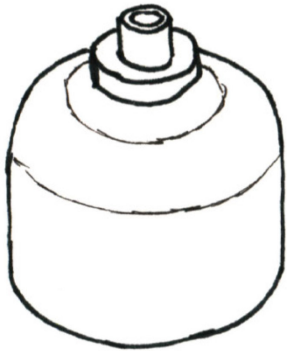

Pictorial view

3mm wall thickness

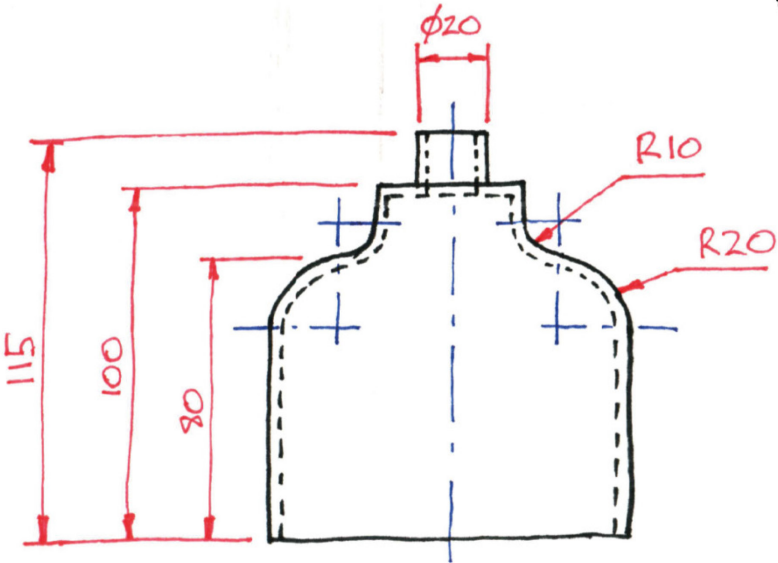

Elevation

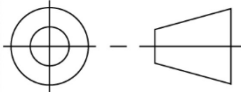

Not to scale

Data sheet 1e

Stem

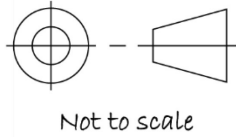
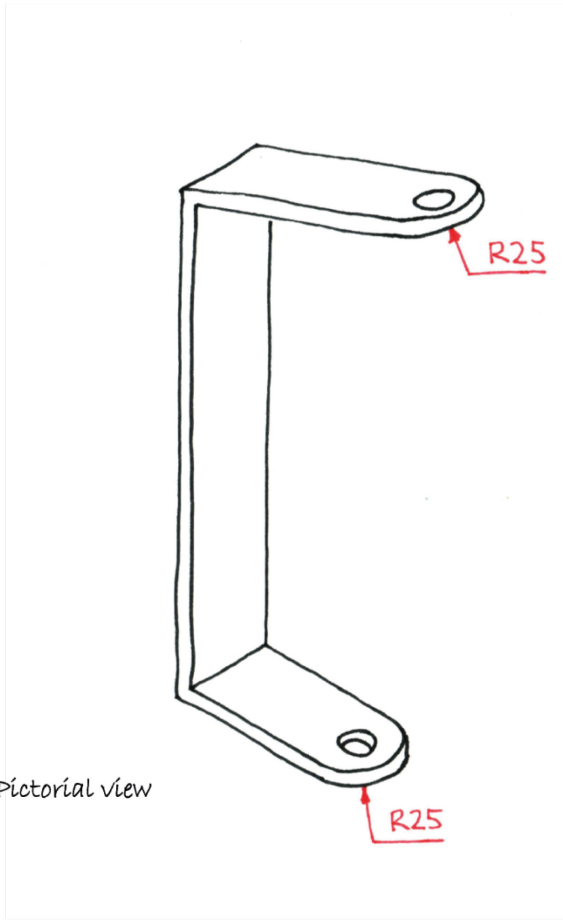
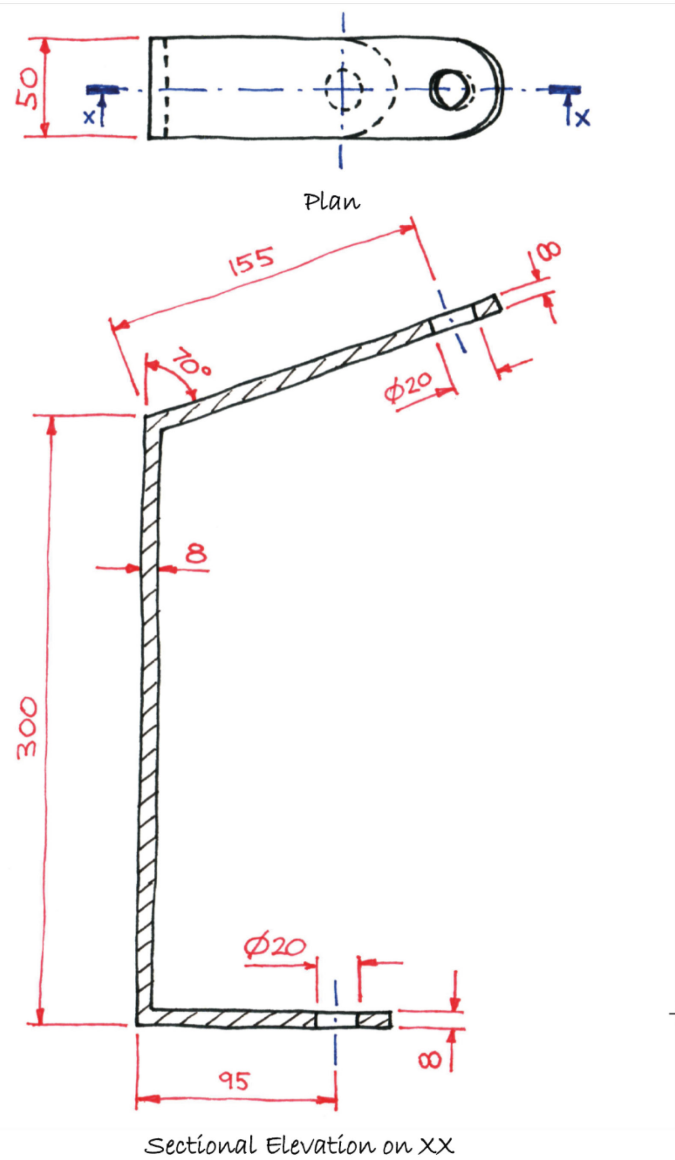

Data sheet 2a

The top panel must be produced to the dimensions 340mm x 170mm.
The panel is laid out in landscape orientation, as shown in the example below.



You must use this title:

Lumo desk lamp

The font style used in the company logo is
TW Cen MT.

You do not have to use this font style in
your DTP layout.

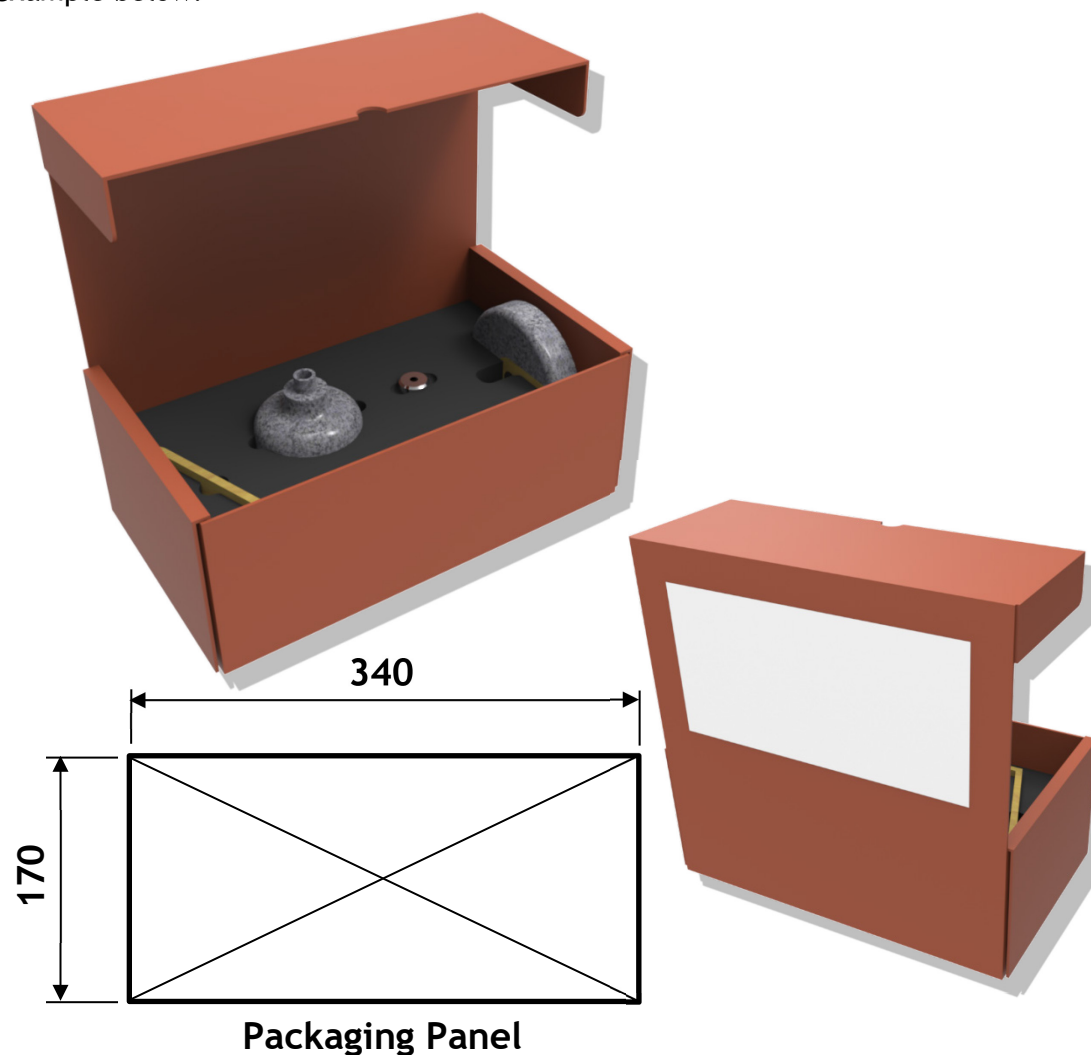

Data sheet 2b

Image 1

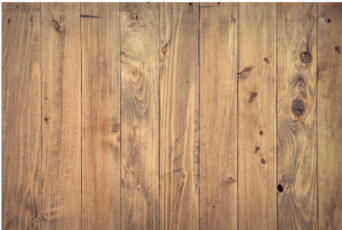

Image 2



Image 3



Image 4

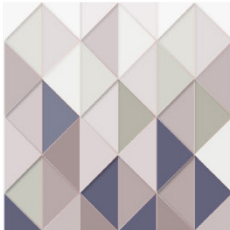

Image 14

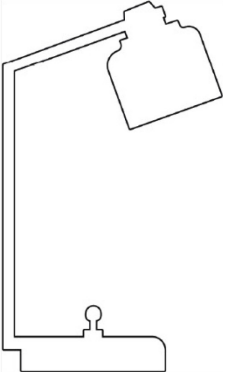

Image 5



Image 6



Image 7



Image 8



Image 15

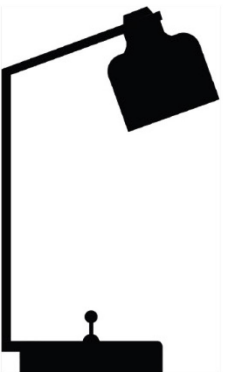

Image 9

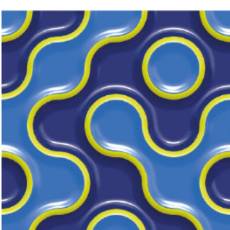

Image 10

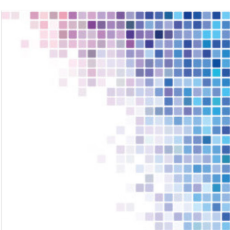

Image 11

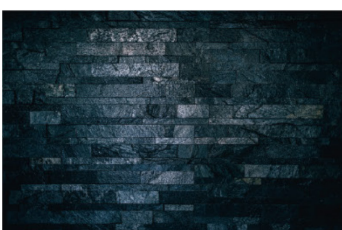

Image 12



Image 13



Data sheet 3a

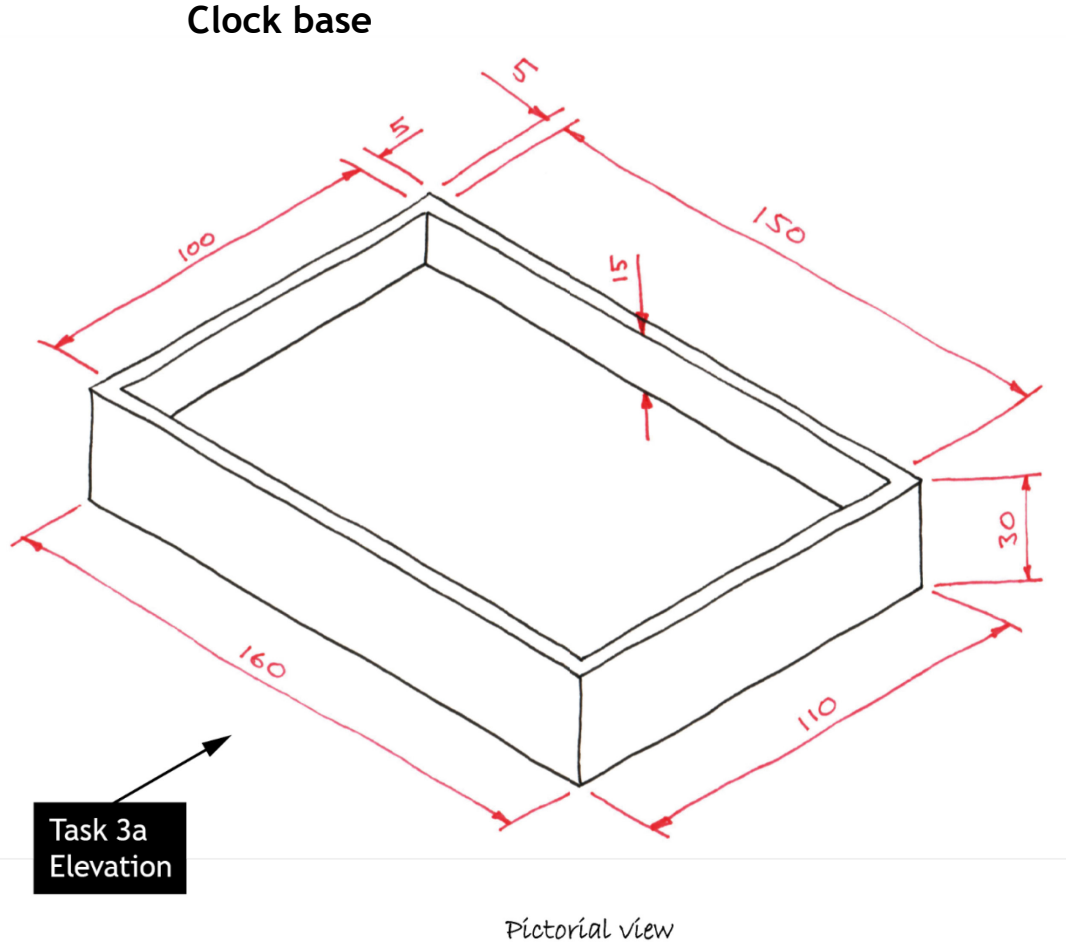
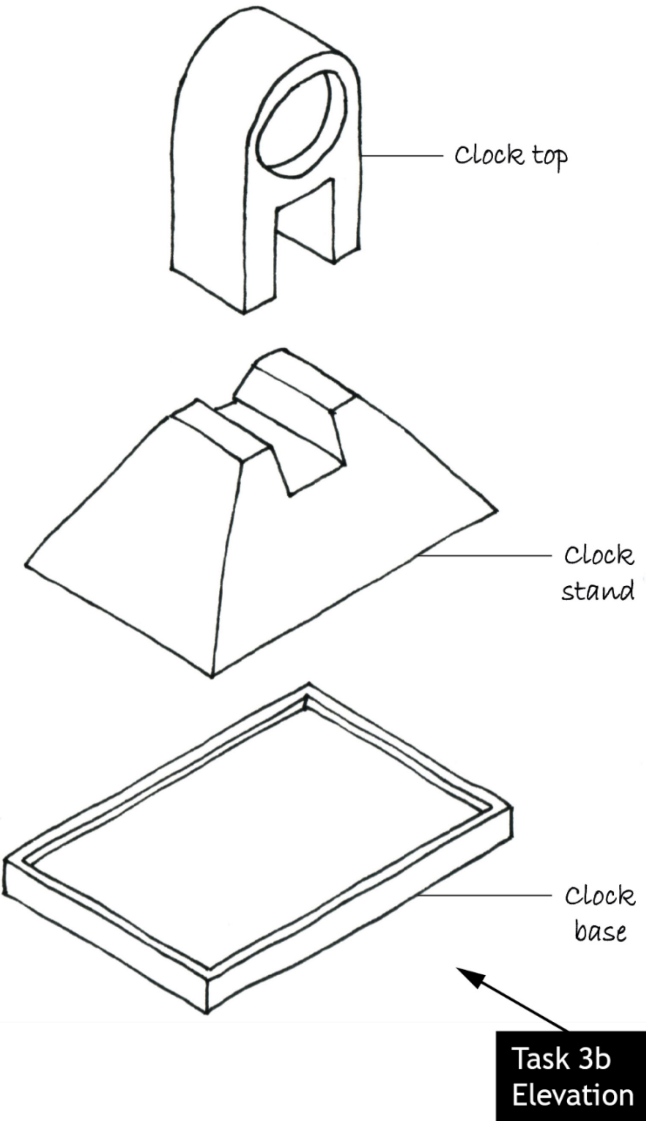

Data sheet 3b

Clock stand

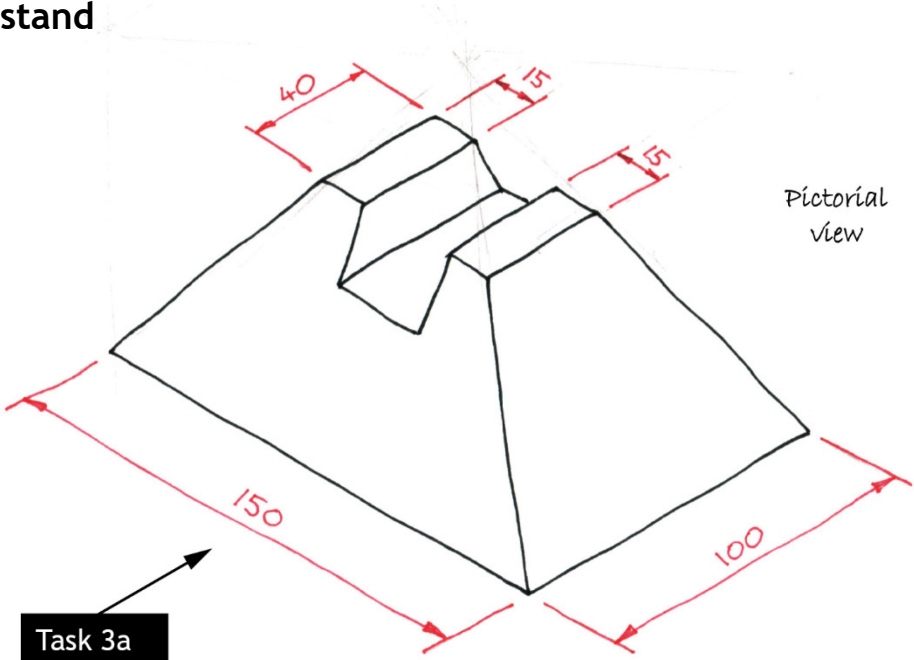

Task 3a
Elevation

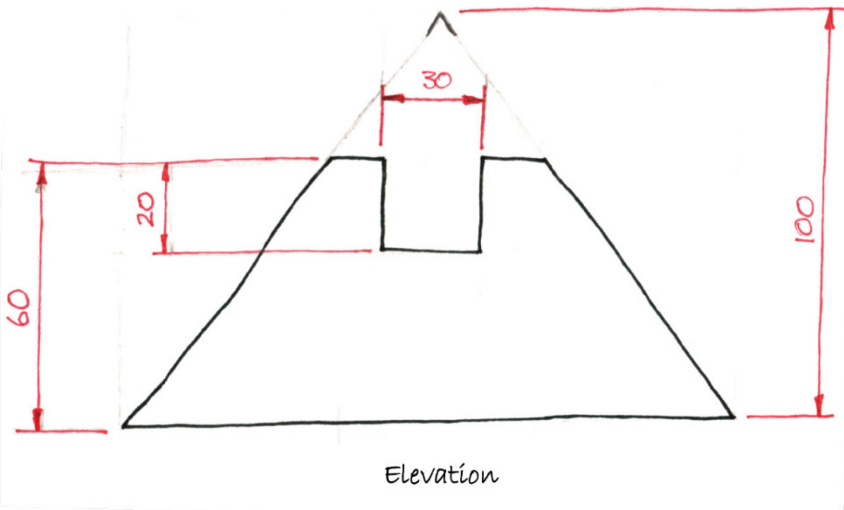

Data sheet 3c

Clock top

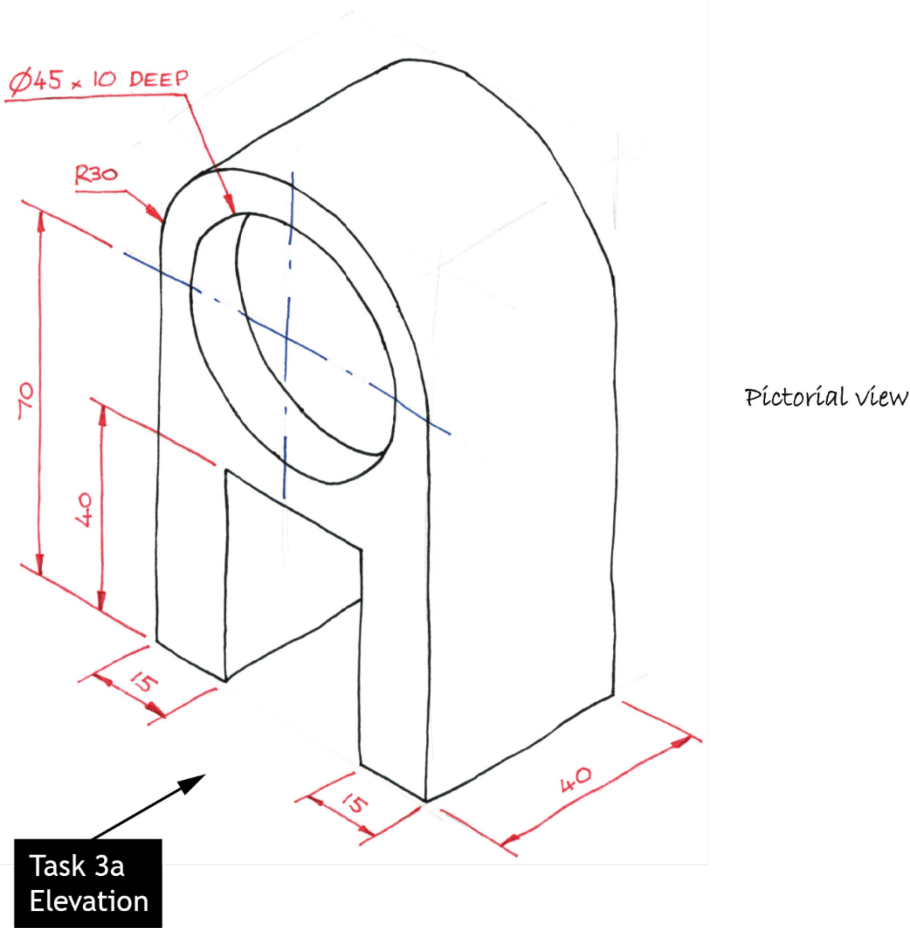

Copyright acknowledgements

Data Sheet 2b

All images are taken from Pexels and Pixabay - Creative Commons Zero License

Electronic files

All images are taken from Pexels and Pixabay - Creative Commons Zero License

Administrative information

Published: December 2022 (version 1.0)

History of changes

Version	Description of change	Date
1.1	Updated to remove crop marks from electronic version. No changes to information contained within data sheets.	06/12/22

Security and confidentiality

This document can be used by practitioners in SQA approved centres for the assessment of National Courses and not for any other purpose.

This document may only be downloaded from SQA's designated secure website by authorised personnel.

© Scottish Qualifications Authority 2022