

FOR OFFICIAL USE



National
Qualifications
2021 ASSESSMENT RESOURCE

Mark

X823/75/01

Engineering Science

Duration — 1 hour 50 minutes



Fill in these boxes and read what is printed below.

Full name of centre

Town

Forename(s)

Surname

Number of seat

Date of birth

Day

Month

Year

Scottish candidate number

Total marks — 110

SECTION 1 — 20 marks

Attempt ALL questions.

SECTION 2 — 90 marks

Attempt ALL questions.

Show all working and units where appropriate.

You should refer to the National 4/5 Engineering Science Data Booklet which you have been given.

The number of significant figures expressed in a final answer should be equivalent to the least significant data value given in the question. Answers that have two more figures or one less figure than this will be accepted.

Write your answers clearly in the spaces provided in this booklet. Additional space for answers is provided at the end of this booklet. If you use this space you must clearly identify the question number you are attempting.

Use **blue** or **black** ink.

Before leaving the examination room you must give this booklet to the Invigilator; if you do not, you may lose all the marks for this paper.





SECTION 1 — 20 marks

Attempt ALL questions

1. Complete the table below which shows the four types of motion.
The first one is completed for you.

3

| Motion name | Graphic |
|---------------|-------------------------------------------------------------------------------------|
| linear |  |
| reciprocating | |
| |  |
| oscillating | |

2. Calculate the strain when a 14 m long cable experiences a change in length of 0.0021 m.

2



* X 8 2 3 7 5 0 1 0 2 *

3. An incomplete pneumatic circuit is shown.

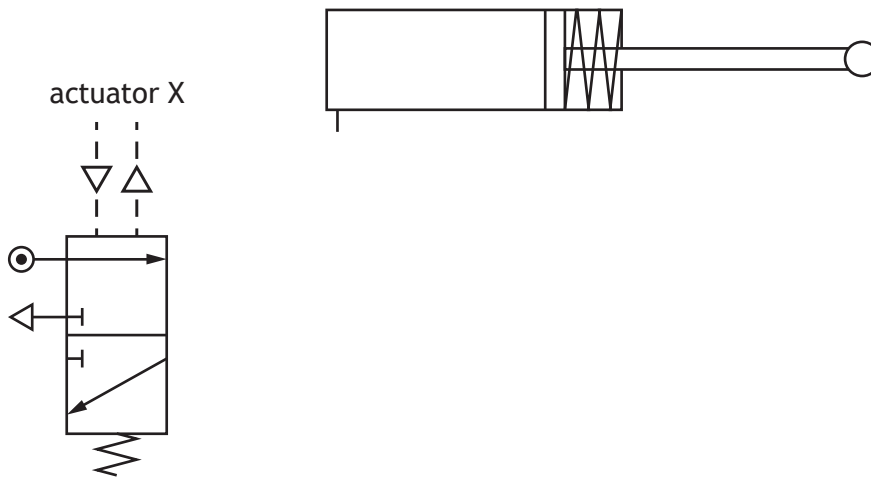

(a) Complete the piping between the valve and cylinder to keep the piston outstroked.

1

(b) State the name of actuator X.

1

4. An incorrect free body diagram of a structure in equilibrium is shown below.

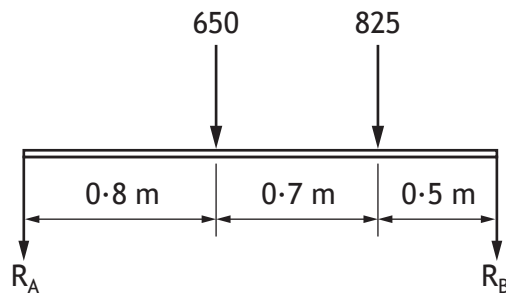

Describe two different errors in the diagram.

2

Error 1 _____

Error 2 _____

[Turn over



* X 8 2 3 7 5 0 1 0 3 *

5. An engineer is to design and test an electronic circuit.

(a) Draw the symbol for a voltmeter.

1



(b) State the name of the component that allows a low power electronic circuit to switch on a high power electrical circuit.

1

(c) Draw the symbol for a diode.

1



* X 8 2 3 7 5 0 1 0 4 *

6. A scaffolding tower is used to allow work to be carried out safely at height.

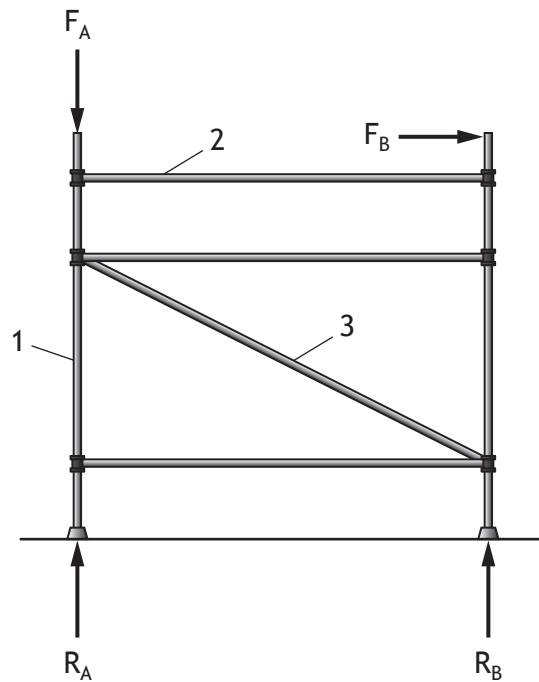

The forces acting on the scaffolding tower are shown above.

(a) (i) State the nature of the force in member 1 and member 2. 2

Member 1 _____

Member 2 _____

(ii) Describe the function of member 3. 1

(b) State the type of engineer who would calculate the maximum safe load that the scaffolding tower can withstand. 1

[Turn over



7. Microcontroller based systems are often used to create open loop and closed loop control.

(a) Describe the **difference** between open loop control and closed loop control.

2

(b) Describe two advantages of a microcontroller based system compared to a hard wired electronic circuit.

2

Advantage 1 _____

Advantage 2 _____



* X 8 2 3 7 5 0 1 0 6 *

[Turn over for next question

DO NOT WRITE ON THIS PAGE



* X 8 2 3 7 5 0 1 0 7 *

SECTION 2 — 90 marks
Attempt ALL questions

8. A flash unit used with a camera is shown.



The flash unit is used when taking a photograph in low light conditions. A signal is sent from the camera to the flash unit when it is about to take a picture.

A simplified sub-system diagram for the flash unit is shown below.

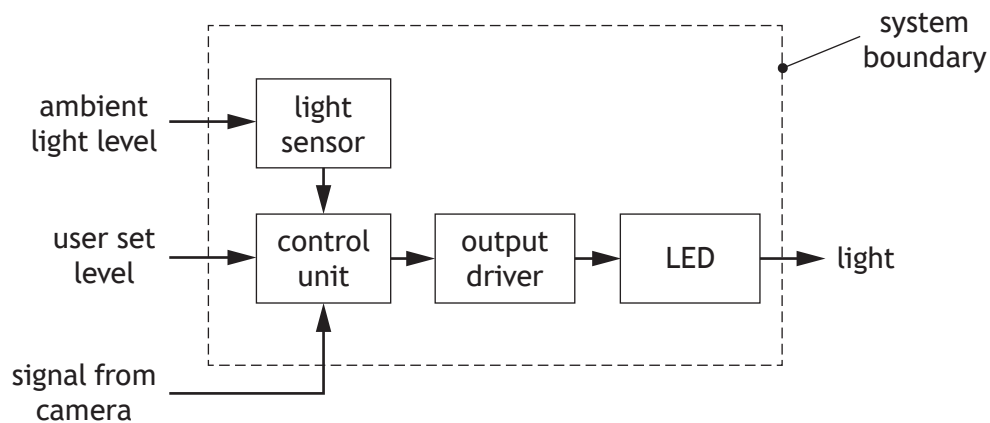

(a) Describe the purpose of the system boundary in a sub-system diagram. 1



MARKS

DO NOT
WRITE IN
THIS
MARGIN

8. (continued)

- (b) Describe, with reference to the sub-system diagram shown opposite, the operation of the flash unit.

2

When a signal from the camera is received . . .

[Turn over



* X 8 2 3 7 5 0 1 0 9 *

8. (continued)

The circuit used to detect the light level is shown below.

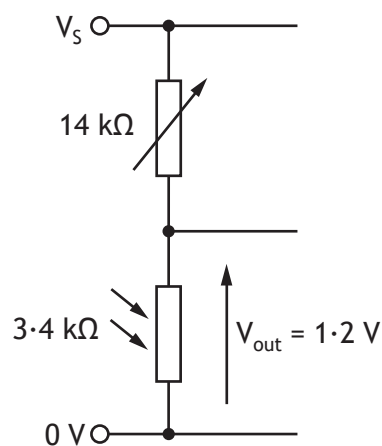

(c) State the name of this type of series circuit.

1

(d) Calculate the supply voltage (V_s) for the conditions shown.

4



8. (continued)

Part of the logic diagram used in the control of the flash unit is shown.

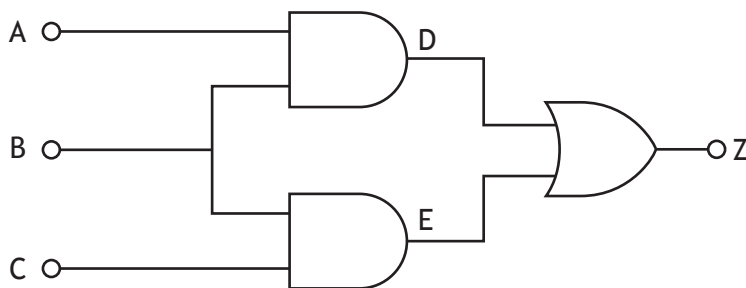

(e) Complete the truth table for the logic diagram shown above.

3

| A | B | C | D | E | Z |
|---|---|---|---|---|---|
| 0 | 0 | 0 | | | |
| 0 | 0 | 1 | | | |
| 0 | 1 | 0 | | | |
| 0 | 1 | 1 | | | |
| 1 | 0 | 0 | | | |
| 1 | 0 | 1 | | | |
| 1 | 1 | 0 | | | |
| 1 | 1 | 1 | | | |

A second logic diagram used in the control of the flash unit is shown below.

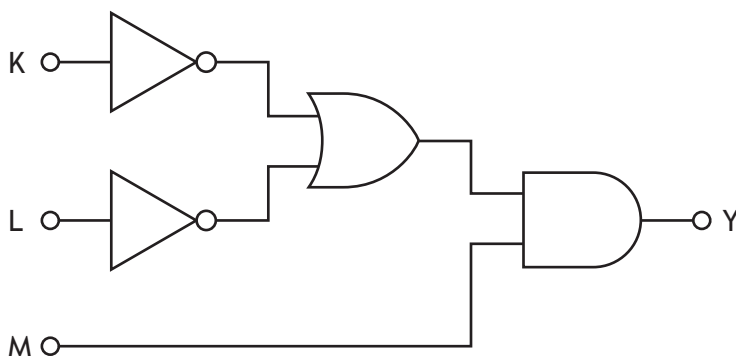

(f) Complete the Boolean equation, in terms of inputs K, L and M, for this logic diagram.

3

Y = _____



9. A moving walkway in an airport is shown.



The circuit used to operate the walkway motor and two warning lamps is shown.

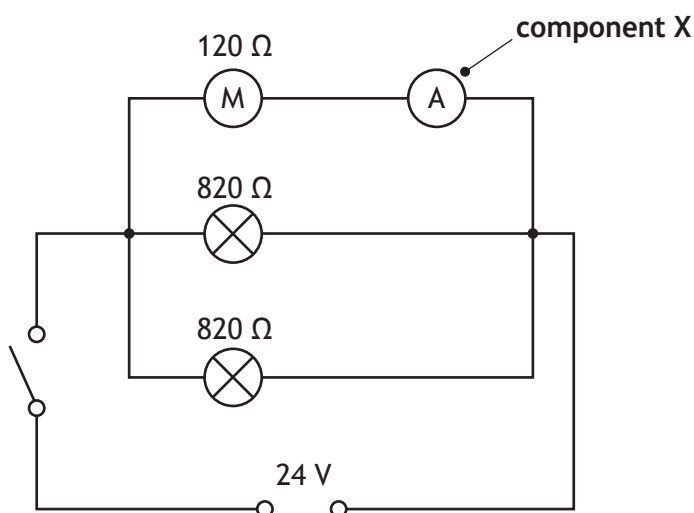

(a) Describe the function of **component X** in the circuit shown above.

2



9. (continued)

(b) Calculate, for the circuit shown opposite

(i) the total resistance

3

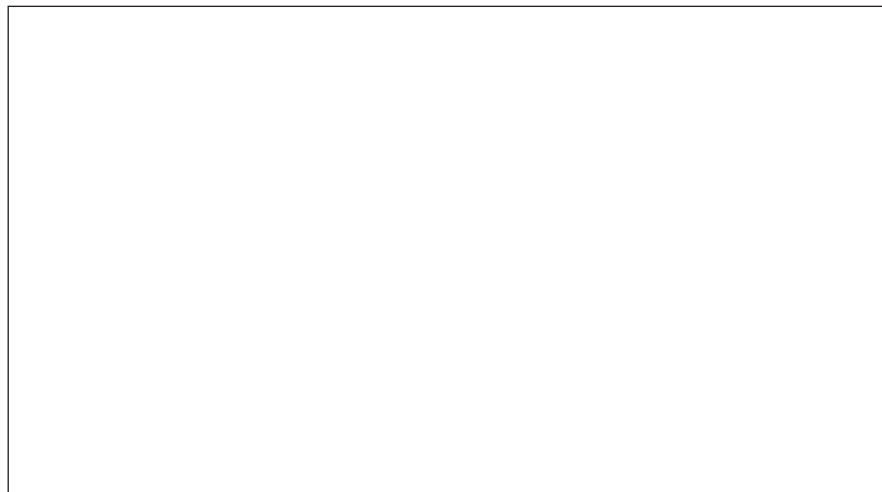

(ii) the total circuit current when the switch is closed.

3

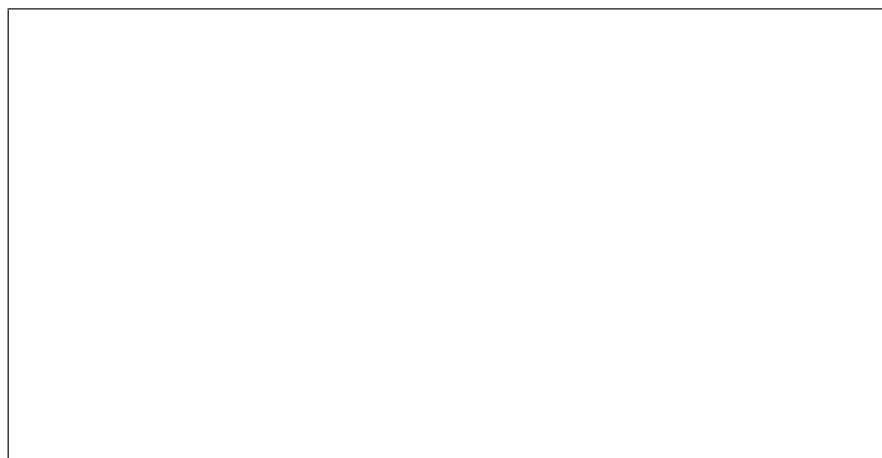

(c) Describe an **economic** impact that occurs **during** the construction of the walkway.

1

(d) Describe a **social** impact of having a moving walkway in an airport.

1



9. (continued)

A number of different engineers were involved in the development of the walkway.

(e) Describe a specific role that each of the following engineers would undertake in the development of the walkway.

(i) A *mechanical engineer* would *design* . . .

1

(ii) An *electrical engineer* would *calculate* . . .

1



* X 8 2 3 7 5 0 1 1 4 *

10. A slow cooker is shown.



The cooking pot has a specific heat capacity of $910 \text{ J kg}^{-1} \text{ K}^{-1}$ and a mass of 1.6 kg .

- (a) Calculate the heat energy used to increase the temperature of the cooking pot by 25°C .

2

[Turn over



10. (continued)

The heating element in the slow cooker is rated at 230 V, 1.1 A.

(b) (i) Calculate the input electrical energy used in 120 minutes.

3

(ii) Calculate the output energy in this time if the slow cooker is 0.72 (72%) efficient.

3



* X 8 2 3 7 5 0 1 1 6 *

11. Part of a zip slide and its rider is shown at the start of the run down a hillside.



The forces acting on the zip slide cables are analysed using the scale drawing of the triangle of forces shown below.

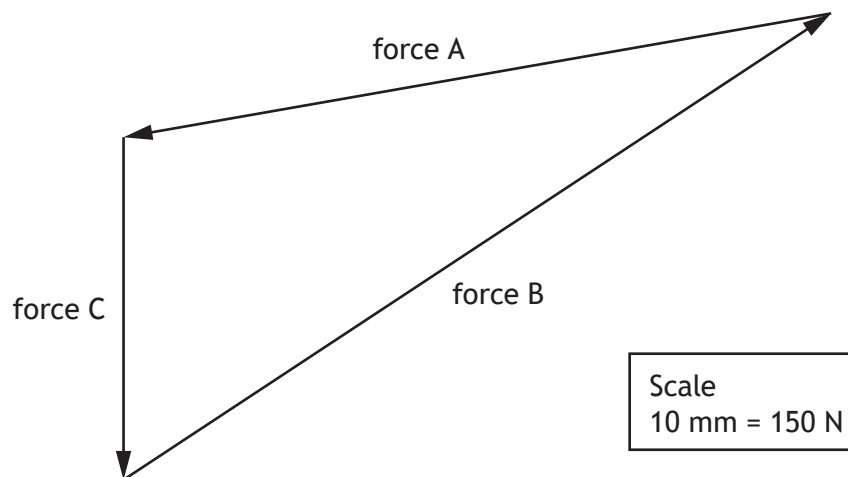

(a) Determine, with reference to the triangle of forces, the size of force A. 1

_____ N



11. (continued)

When a force of 680 N is applied to the cable holding the rider, it experiences a stress of 13 N mm^{-2} .

(b) Calculate the cross-sectional area of the cable.

3

[Turn over



* X 8 2 3 7 5 0 1 1 9 *

11. (continued)

The properties of four materials considered for the cable holding the rider are shown in the table below.

| Material | Maximum force | Performs best in | Corrosion resistant |
|----------|---------------|------------------|---------------------|
| A | 7200 N | compression | no |
| B | 7200 N | tension | no |
| C | 7200 N | compression | yes |
| D | 7200 N | tension | yes |

- (c) Select the most suitable material from the table to be used for the support cable and justify your choice.

2

Choice of material _____

Justification for choice _____

A structural engineer uses computer simulation during the design of the zip slide's supporting structure.

- (d) Explain why using computer simulation is preferable to building a prototype when designing the supporting structure.

2



11. (continued)

The next rider on the zip slide has a mass of 75 kg and a velocity of 13 m s^{-1} .

(e) Calculate the kinetic energy of this rider.

2

[Turn over



* X 8 2 3 7 5 0 1 2 1 *

12. Two pneumatic pistons used to hold material in place on a production line are shown.

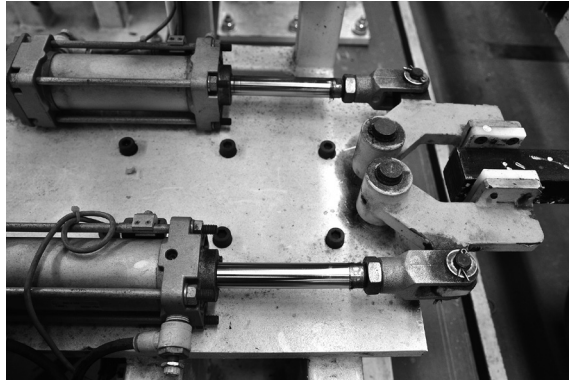

The electro-pneumatic circuit used to control the operation of the two pistons is shown below.

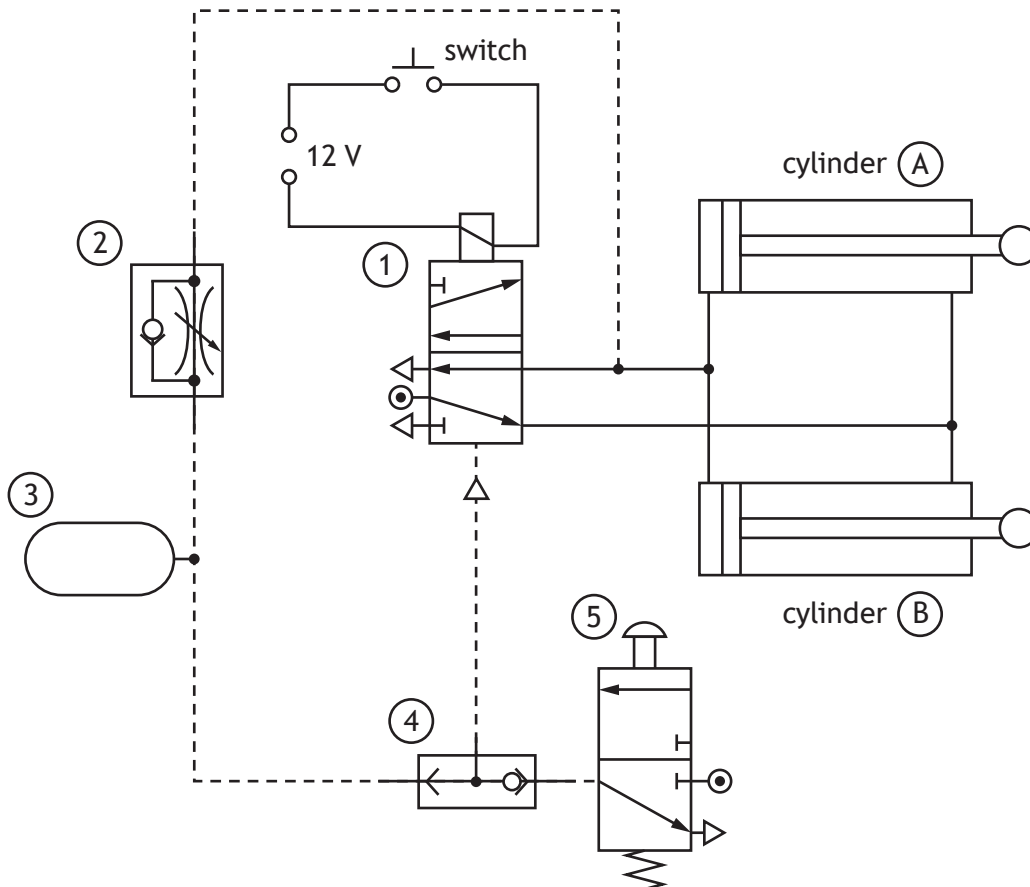

12. (continued)

- (a) Describe using appropriate terminology, the operation of the circuit shown opposite.

3

When the electrical switch is activated . . .

The circuit is to be modified so that both pistons outstroke slowly.

An engineer tests a uni-directional restrictor in each of the positions shown (D, E and F) to restrict the **exhaust** air as the pistons outstroke.

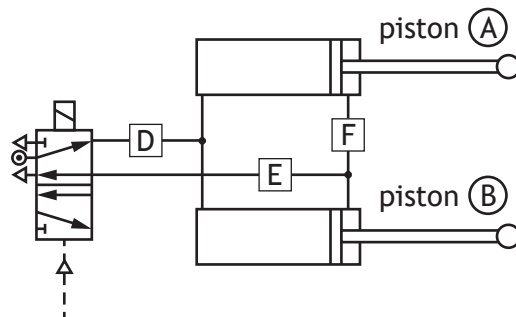

- (b) Describe the effect on the **outstroke** of pistons (A) and (B) of piping a uni-directional restrictor in these positions.

3

D _____

E _____

F _____



* X 8 2 3 7 5 0 1 2 3 *

12. (continued)

The air pressure supplied to the circuit is 0.50 N mm^{-2} .

(c) Calculate the outstroking force of a 42 mm diameter piston.

4

The electronic circuit used to activate valve ① is shown below.

The solenoid used in the circuit is rated at 12 V, 4.5 W.

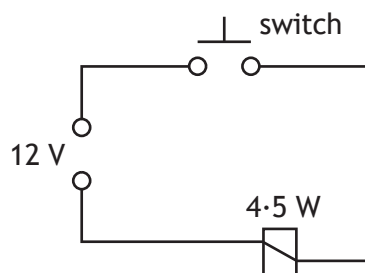

(d) Calculate the current in the circuit when the switch is closed.

3



13. A solar powered rubbish compactor which crushes waste to increase its storage capacity is shown.

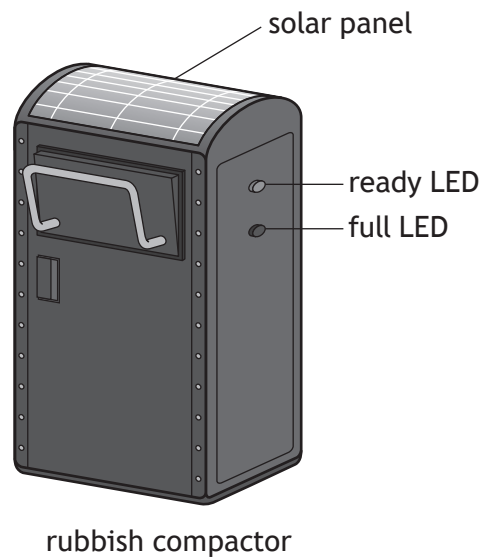

- (a) Explain why solar panels can contribute towards limiting climate change. 2

[Turn over



13. (continued)

A microcontroller is used to operate the rubbish compactor using the following sequence. The sequence runs after the rubbish compactor has been emptied and reset.

- A full LED will switch off and a ready LED will switch on
- When a rubbish level sensor is activated, a crusher will start to move down
- The crusher will stop when a force sensor is activated
- After a delay of 0.5 seconds the crusher will move up until a limit switch is activated
- If the rubbish level sensor is off, the sequence will return to the start
- If the rubbish level sensor is still activated the ready LED will switch off and the full LED will switch on
- The sequence will end

Input and output connections to the microcontroller are shown in the table below.

| Input connection | Pin | Output connection |
|----------------------|-----|-------------------|
| | 7 | crusher up |
| | 6 | crusher down |
| | 5 | full LED |
| | 4 | ready LED |
| force sensor | 2 | |
| limit switch | 1 | |
| rubbish level sensor | 0 | |

(b) Complete the flowchart opposite for this sequence, with reference to the data booklet and input/output connections.

Include **all** pin numbers and the delay unit in your flowchart.

11



13. (b) (continued)

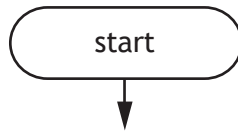

13. (continued)

A rubbish compactor can store five times more rubbish than standard bins and therefore can be emptied less often.

- (c) Explain an **environmental** impact of not having to empty the bin as often. 2



* X 8 2 3 7 5 0 1 2 8 *

[Turn over for next question

DO NOT WRITE ON THIS PAGE



* X 8 2 3 7 5 0 1 2 9 *

14. A snow making machine used in a ski resort is housed in a container.

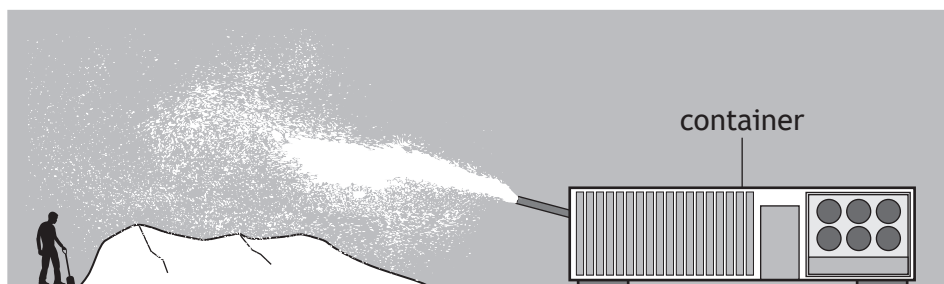

A simplified free body diagram of the forces acting on the base of the container is shown below.

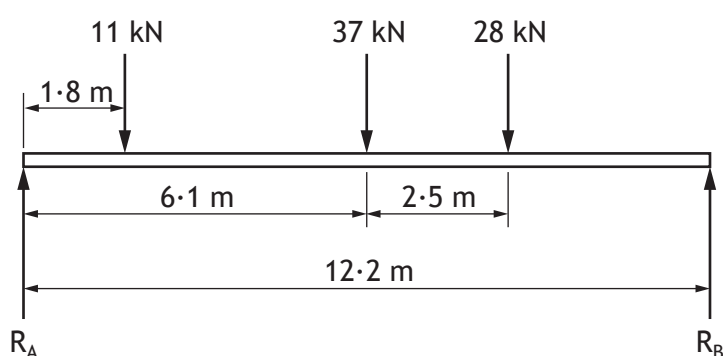

(a) Calculate by taking moments about R_A , the reaction force R_B .

3



14. (continued)

(b) Calculate the reaction force R_A .

2

[Turn over



* X 8 2 3 7 5 0 1 3 1 *

14. (continued)

Ice is to be broken up by a cutter during the snow making process.
The cutter is driven by a compound gear train as shown below.

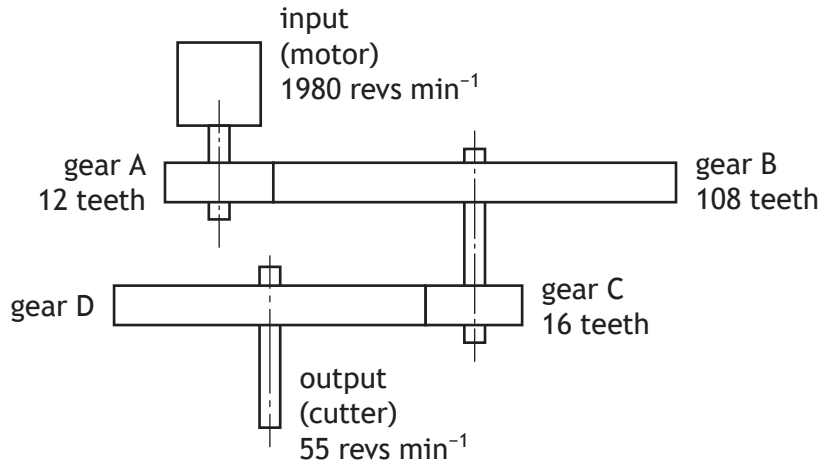

(c) Explain how the efficiency of a compound gear train can be increased. 2



14. (continued)

- (d) Calculate the number of teeth on gear D in the compound gear train shown.

4

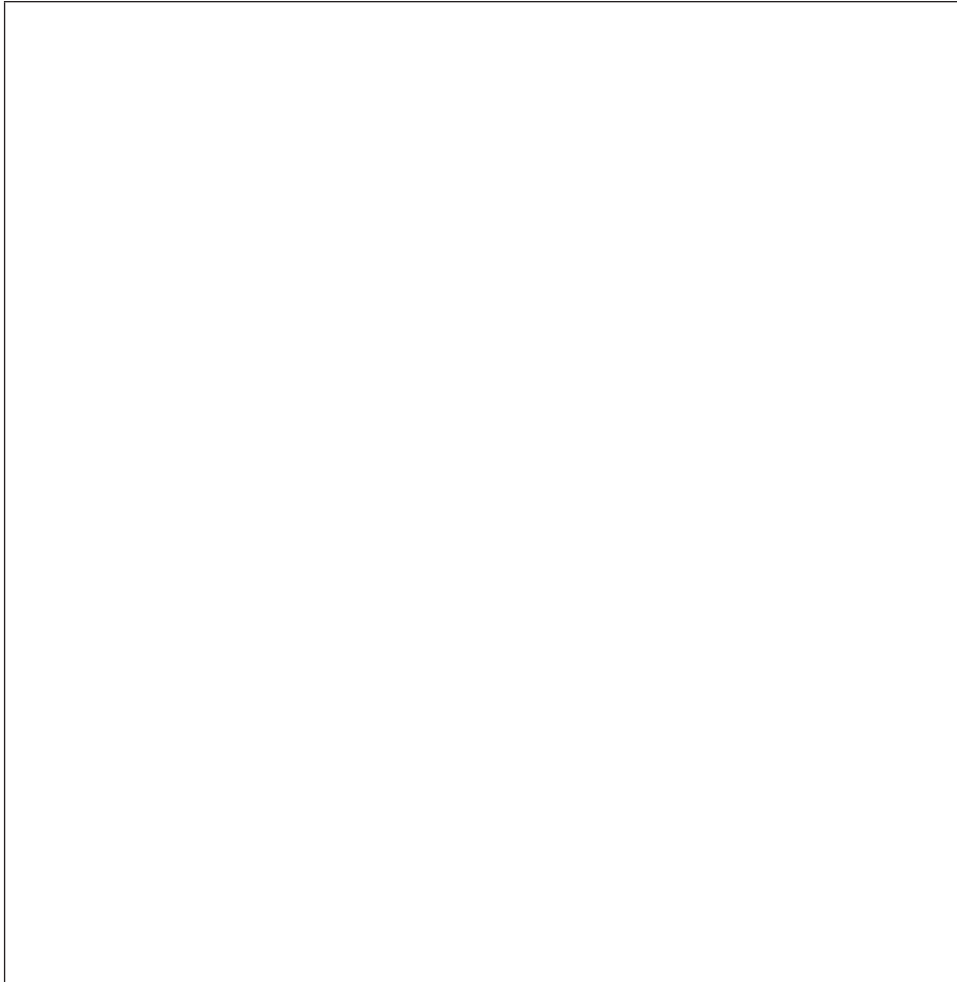

- (e) Describe a modification to the compound gear train that results in gear D rotating in the opposite direction to gear A.

2

[END OF QUESTION PAPER]



* X 8 2 3 7 5 0 1 3 3 *

MARKS

DO NOT
WRITE IN
THIS
MARGIN

ADDITIONAL SPACE FOR ANSWERS



* X 8 2 3 7 5 0 1 3 4 *

MARKS

DO NOT
WRITE IN
THIS
MARGIN

ADDITIONAL SPACE FOR ANSWERS



* X 8 2 3 7 5 0 1 3 5 *

[BLANK PAGE]

DO NOT WRITE ON THIS PAGE

Acknowledgement of copyright

- Question 8 Maxx-Studio/shutterstock.com
- Question 8 Marco Rubino/shutterstock.com
- Question 9 Christophe Testi/shutterstock.com
- Question 10 Lighttraveler/shutterstock.com
- Question 12 thanakarn Singto/shutterstock.com



* X 8 2 3 7 5 0 1 3 6 *