

The logo consists of the letters 'N5' in a large, bold, white font, set against a solid purple square background.

National 5  
Coursework  
Assessment Task



---

# National 5 Engineering Science Assignment

## Assessment task: theme park

Valid for session 2019-20 only.

**This assessment is given to centres in strictest confidence. You must keep it in a secure place until it is used.**

This edition: January 2020 (version 1.0)

© Scottish Qualifications Authority 2020

# Contents

Introduction	1
Instructions for teachers and lecturers	2
Instructions for candidates	6
Worksheets	24

# Introduction

This document contains instructions for teachers and lecturers, and instructions for candidates for the National 5 Engineering Science assignment. It must be read in conjunction with the course specification.

This assignment has 50 marks out of a total of 160 marks available for the course assessment.

This is one of two course assessment components. The other component is a question paper.

# Instructions for teachers and lecturers

This task is valid for session 2019-20 only. Once complete, you must send the assignment responses to SQA to be marked.

You must conduct the assignment under a high degree of supervision and control.

This means:

- ◆ all candidates must be within your direct sight
- ◆ candidates must not interact with each other
- ◆ candidates must not have access to e-mail, the internet and mobile phones
- ◆ candidates must complete their work independently – no group work is permitted
- ◆ classroom display materials that might provide assistance must be removed or covered
- ◆ there must be no interruption for learning and teaching
- ◆ candidates must be in a classroom environment

## Time

Candidates have 8 hours to complete the assignment, starting at an appropriate point in the course after all content has been delivered. Once candidates begin their assignment, they must continue in each subsequent class period until the permitted time allocation has been used up.

You have a responsibility to manage candidates' work, distributing it at the beginning and collecting it at the end of each period, and storing it securely in-between. This activity does not count towards the total time permitted for candidates to complete the assignment.

## Resources

This is a closed-book assessment. Candidates must not have access to learning and teaching materials, the internet, notes, exemplar materials, resources on classroom walls or anything similar.

A data booklet containing relevant data and formulae is available on the National 5 Engineering Science subject page on SQA's website. This can be used for the assignment.

Each assessment task includes instructions and details of any equipment or materials required for the assignment. Candidates can also use normal classroom equipment, software and hardware (such as drawing instruments, pneumatics, mechanisms and electronics kit, simulation software, and PCs to run the software) to complete the tasks.

There may be instances where restriction of internet and/or network use is not practical or feasible (for example, a local authority-managed network with specific limitations, software that is web-based, or something similar), however, it remains your professional responsibility to make every effort to meet the assessment conditions.

## Reasonable assistance

Candidates must progress through each stage of the assignment without your intervention or guidance, having acquired the skills earlier in the course.

Once candidates complete the assignment, you must not return it to them for further work. You must not provide feedback to candidates or offer your opinion on the perceived quality or completeness of the assignment response at any stage.

You can provide reasonable assistance to support candidates with the following aspects of their assignment:

- ◆ printing, collating and labelling their evidence to ensure it is in the format specified by SQA
- ◆ ensuring candidates have all the materials and equipment required to complete the assignment
- ◆ understanding the information outlined in these instructions

## Evidence

All candidate evidence (whether created manually or electronically) must be submitted to SQA in paper-based format.

Each task details what evidence is required and how many pages are expected. This is a guide to ensure that candidates do not produce too much or spend too long on a single task.

Candidates must submit single-sided A4 pages. The pages must not have anything fixed to them. Any screenshots, simulation printouts and/or images must be clear and easy to read.

## Alteration or adaptation

You must not alter, adapt or modify the assignment in any way. This includes moving the content of the assignment into a different format or workbook. All candidates must undertake the assignment exactly as it is provided by SQA.

## Submission

Each piece of work must be labelled with the task number, for example, task 2a, and the back of each page must be clearly labelled with the candidate's details.

Photographs must show the candidate's name next to the piece of work.

Only pages containing candidate evidence are to be submitted and evidence must be submitted in task order.

## Volume

There is no word or page count.

## Specific instructions for teachers and lecturers: 2019-20 assignment

You must follow these specific instructions. You must ensure that candidates are aware of the assessment conditions and know what they should do for each task and any specific information contained in this section.

This assignment has **five** mandatory tasks. Candidates can complete the tasks in the order presented or in an order that helps manage classroom equipment.

Each task has a notional time allocated to it – this provides an indication of how long candidates should spend on the task.

All tasks must be completed on A4 single-sided paper or the worksheets provided, with the task number clearly labelled.

Any evidence printed (screenshots or images) **must be clear and easy to read**.

### Task 1 (8 marks)

Notional time: 1 hour 15 minutes

- ◆ task 1: completed on up to two single-sided A4 pages
- ◆ tasks 1a and 1b: worksheets are provided for these tasks

### Task 2 (9 marks)

Notional time: 1 hour 30 minutes

- ◆ task 2: completed on up to two single-sided A4 pages
- ◆ tasks 2a and 2b: worksheets are provided for these tasks

### Task 3 (4 marks)

Notional time: 45 minutes

- ◆ task 3: completed on up to two single-sided A4 pages
- ◆ task 3a: **candidates must not use simulation software for this task**
- ◆ task 3a: a worksheet is provided for this task

### Task 4 (19 marks)

Notional time: 2 hours 30 minutes

- ◆ task 4: completed on up to five single-sided A4 pages
- ◆ tasks 4b and 4e: worksheets are provided for these tasks

### Task 5 (10 marks)

Notional time: 2 hours

- ◆ task 5: completed on up to five single-sided A4 pages
- ◆ task 5a: **candidates must not use simulation software for this task**
- ◆ tasks 5a, 5c, 5d and 5e: worksheets are provided for these tasks

**Note:** electronically-generated evidence (for example simulations and coding) is included in the expected number of pages for each task. This must be printed off and compiled for uplift by SQA.

# Instructions for candidates

This assessment applies to the assignment for National 5 Engineering Science.

The assignment has 50 marks out of a total of 160 marks available for the course assessment.

It assesses the following skills, knowledge and understanding:

- ◆ demonstrating engineering science skills and creativity
- ◆ analysing engineering problems
- ◆ designing and building (simulating and/or constructing) solutions to engineering problems
- ◆ testing and evaluating solutions to engineering problems

This is a closed-book assessment. Your teacher or lecturer will let you know how the assessment will be carried out and any specific conditions for doing it.

In this assessment, you have to:

- ◆ analyse a problem
- ◆ design a solution to the problem
- ◆ simulate or construct your solution
- ◆ test your solution
- ◆ evaluate your work

You have 8 hours to complete the assignment. The time to set up and clear away any equipment you will need, and for any printing that is necessary, does not count towards the 8 hours.

You may complete the tasks in any order, unless otherwise instructed.

The assignment has five tasks, with marks allocated as follows:

**Task 1 – 8 marks:** analysing a solution (programmable control) for the bumper cars.  
(analysis = 8 marks)

**Task 2 – 9 marks:** designing and testing a solution (pneumatics) for the flight simulator.  
(designing a solution = 6 marks, testing = 3 marks)

**Task 3 – 4 marks:** designing and building a solution (electronics) for the ghost train.  
(designing a solution = 3 marks, building = 1 mark)

**Task 4 – 19 marks:** building, testing, designing and evaluating a solution  
(electronics/programmable control) for the rollercoaster.  
(building = 8 marks, testing = 6 marks, designing a solution = 1 mark,  
evaluating = 4 marks)

**Task 5 – 10 marks:** designing, building, testing and evaluating a solution (mechanisms) for the speed control of the aerial chair ride.  
(designing a solution = 2 marks, building = 2 marks, testing = 2 marks, evaluating = 4 marks)

For each task, you are provided with an engineering science context or situation.

### **Submitting your work**

Your teacher or lecturer will let you know the approximate amount of time to spend on each task, along with any specific information you need and an indication of the number of single-sided A4 pages of evidence that you should produce.

You must label each piece of your work with the task number (for example, task 2a), and on the back of each page include your:

- ◆ name
- ◆ date of birth
- ◆ Scottish Candidate Number (SCN)
- ◆ centre name
- ◆ centre number

## Candidate data sheets – theme park

You can use these data sheets and SQA's National 5 data booklet when completing this assignment. **No other resource material is permitted.**

### Electronic components

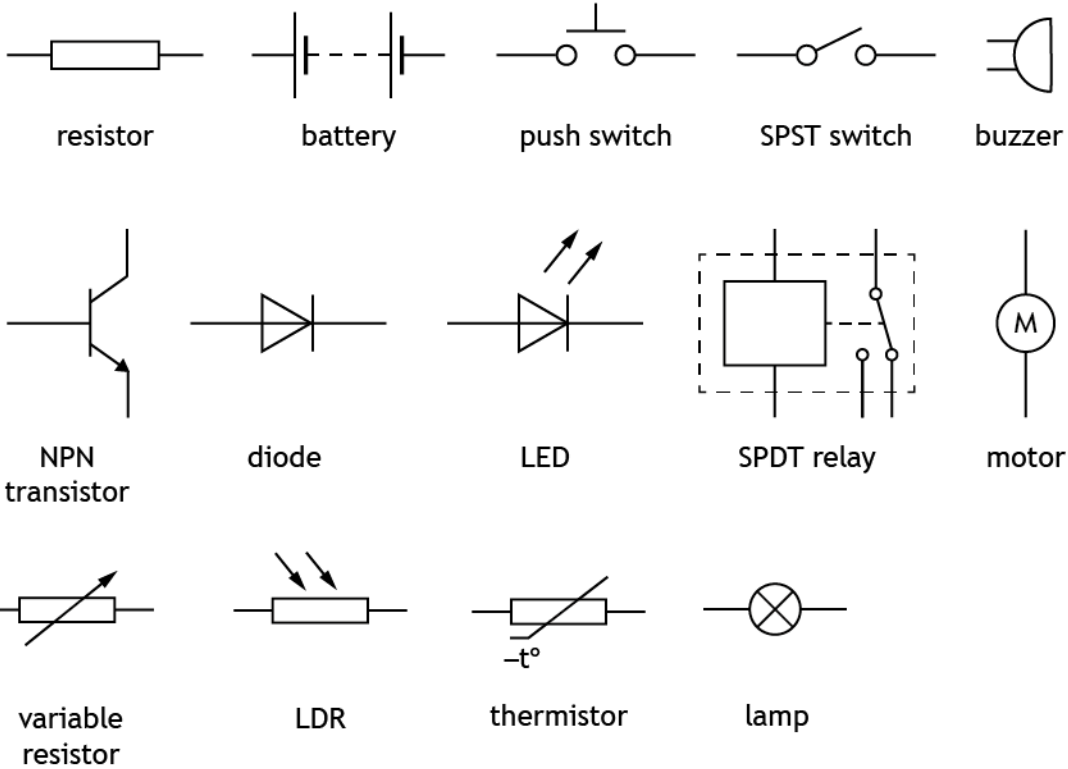

### IC pinout diagrams

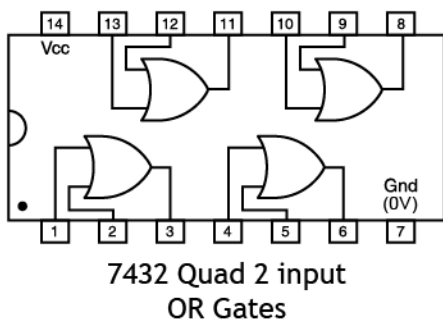
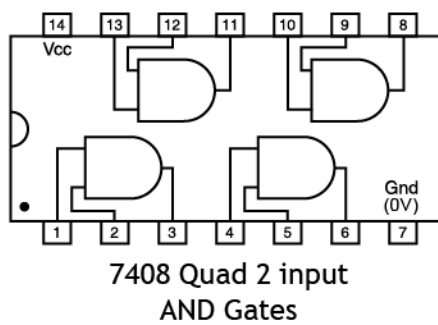
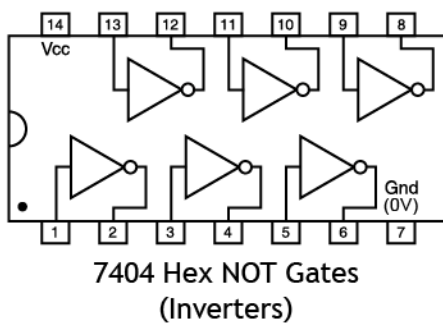

### Logic gates

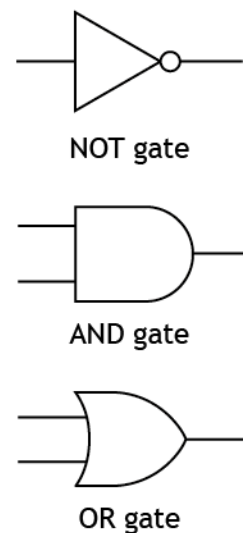

Light Dependent Resistor (LDR) graph for an ORP12 LDR

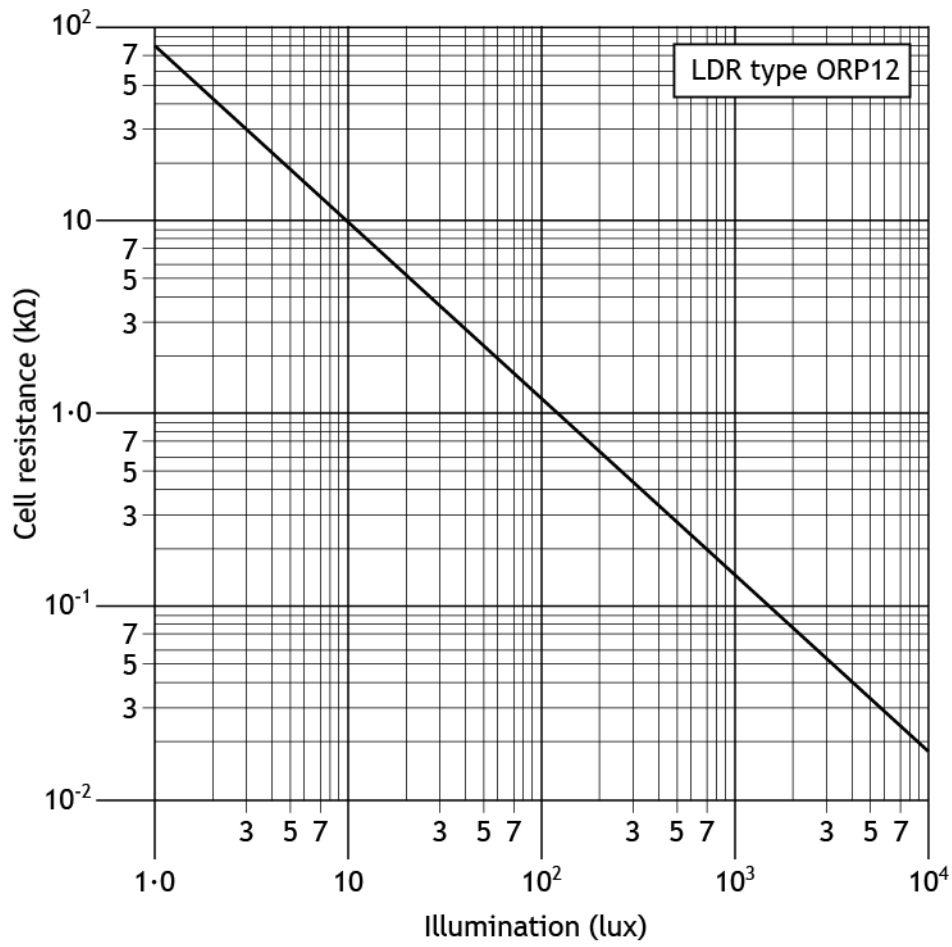

Thermistor graph

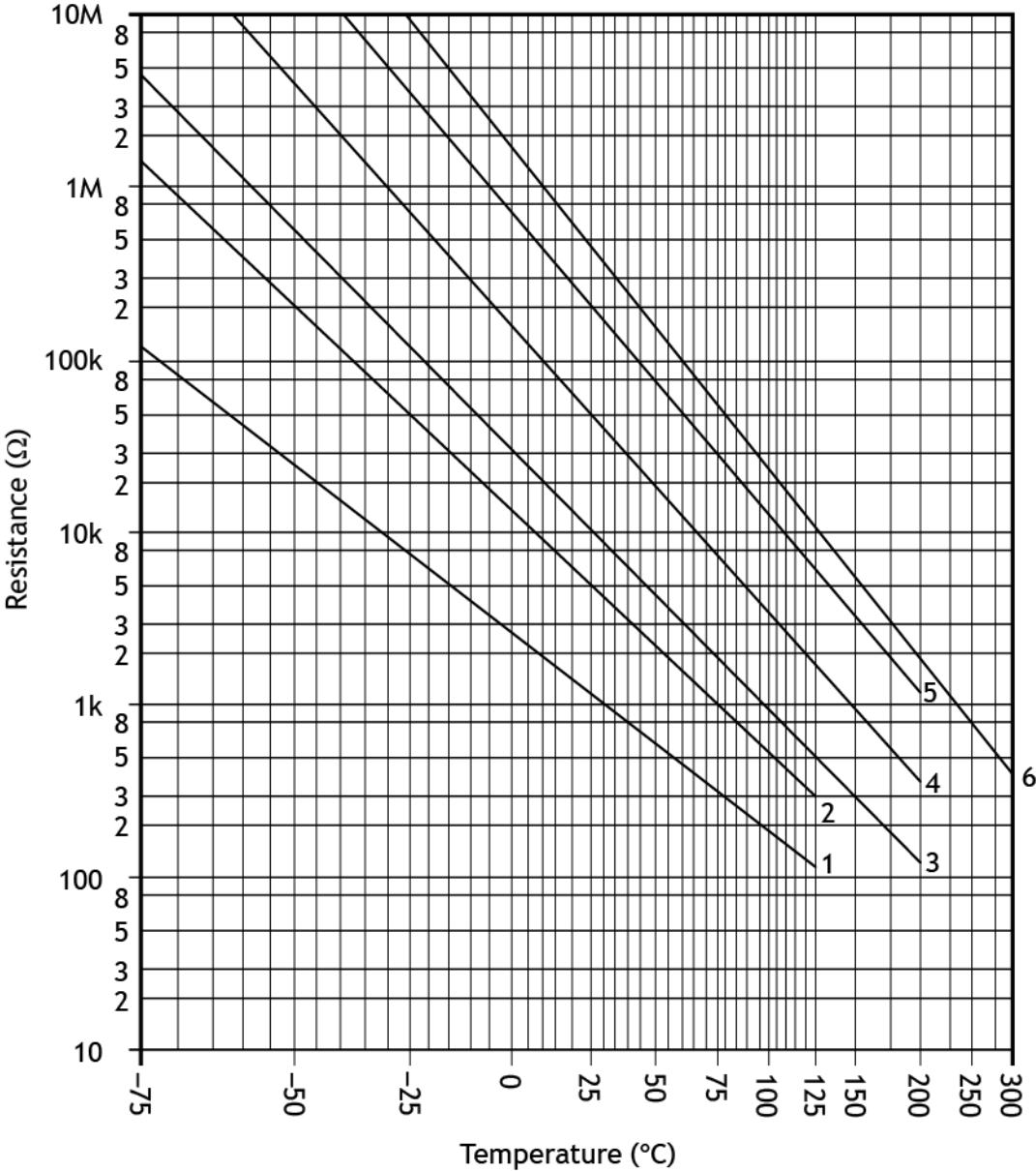

## Pneumatic components

### Actuators

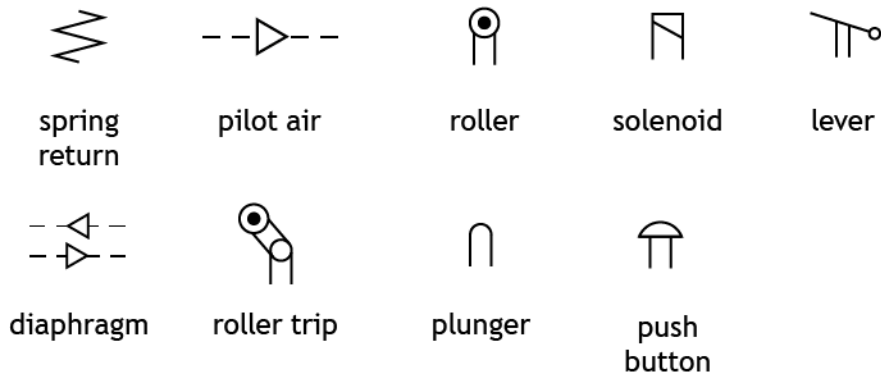

### Valves

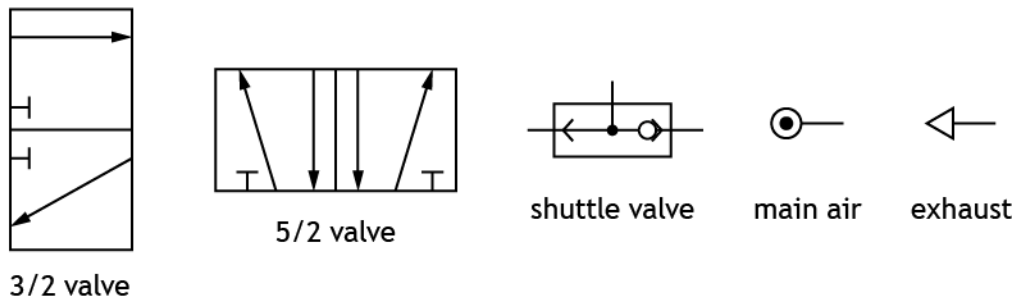

### Components and cylinders

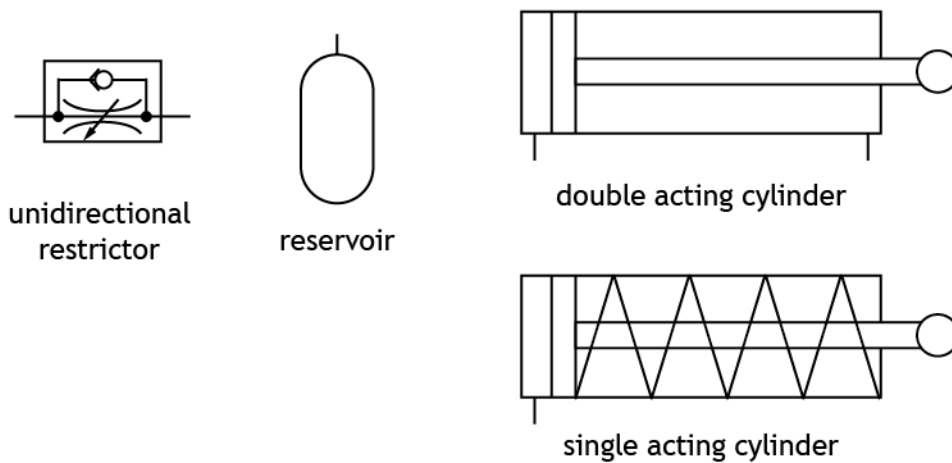

## Theme park

A team of engineers is involved in several tasks during the planning of a new theme park.

These tasks include developing proposals for the following systems:

Task 1 – bumper cars

Task 2 – flight simulator

Task 3 – ghost train

Task 4 – rollercoaster

Task 5 – aerial chair ride

## Task 1 – bumper cars



Bumper cars allow riders to drive around an area while bumping into other cars.

A microcontroller controls the speed of a bumper car and the operation of an LED strip light around it. The specification for the operation of the bumper car is given below.

- i. When the accelerator pedal is pressed, a motor and LED strip light both switch on.
- ii. A sensor measures the speed at which the bumper car is travelling and feeds the information back into the microcontroller.
- iii. The microcontroller lowers the output speed if the bumper car is travelling too fast.

1a Complete the **system diagram** on **worksheet 1a** to meet the specification. You must clearly show all external inputs and outputs.

You must present your evidence on A4 single-sided pages, with the task number clearly labelled.

**(2 marks)**

1b Complete the **sub-system diagram** on **worksheet 1b** to meet the specification. You must clearly show all inputs and outputs, all sub-systems, the system boundary and interactions between sub-systems. **Each output device requires a driver.**

You must present your evidence on A4 single-sided pages, with the task number clearly labelled.

**(6 marks)**

## Task 2 – flight simulator

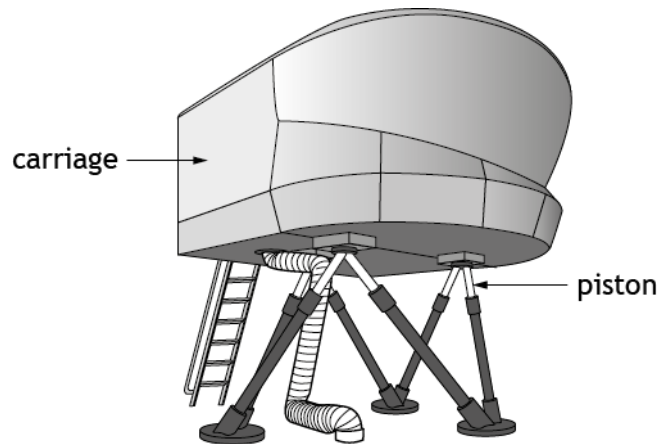

A flight simulator allows riders to experience flying an aeroplane.

A pneumatic system is used to move the flight simulator carriage up and down. A pneumatic circuit used to control one of the carriage's pistons must meet the following specification:

- i. When an electrical actuator on a 3/2 valve receives a signal, a 5/2 valve will cause a double acting cylinder's piston to **outstroke at full speed**.
- ii. An actuator on a second 3/2 valve will detect when the carriage is in the up position.
- iii. After a time delay the piston will **instroke slowly** and smoothly.

2a Complete the design for the pneumatic circuit, on **worksheet 2a**, to meet the specification.

The name of each component, valve and actuator must be identified and the direction of the piston outstroke must be indicated. Show connections between all components and valves.

You must present your evidence on A4 single-sided pages, with the task number clearly labelled.

(6 marks)

Components may be simplified, for example: a pilot-pilot 5/2 valve could be drawn as shown below.

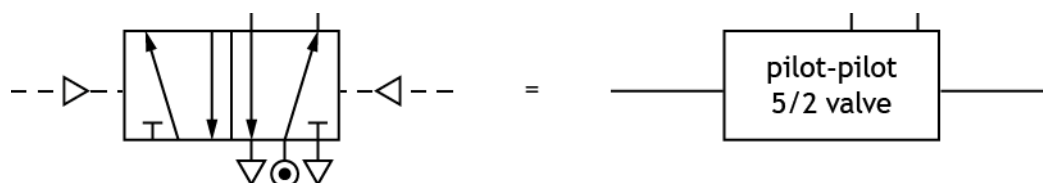

## Task 2 – flight simulator (continued)

2b Complete the test plan on **worksheet 2b** for the pneumatic circuit, to meet the specification, by describing:

- ◆ one test and its expected result for specification point i.
- ◆ the results that would be expected from the given test for specification points ii and iii.

You must present your evidence on A4 single-sided pages, with the task number clearly labelled.

**(3 marks)**

### Task 3 – ghost train



A ghost train takes riders through a haunted house.

A motor on the ghost train should only operate (logic 1) when a safety barrier is down (logic 1) and an operator has pressed a start switch (logic 1) and an emergency stop button is off (logic 0).

- 3a Complete the logic diagram on **worksheet 3a** to control the operation of the ghost train motor as described above.

**You must not construct or use simulation software to complete task 3a.**

You must present your evidence on A4 single-sided pages, with the task number clearly labelled.

**(3 marks)**

- 3b Simulate or construct your design for the logic diagram from **task 3a**. You must include suitable input and output devices to allow for testing. If constructed, IC numbers must be clearly labelled.

You must present your evidence on A4 single-sided pages, with the task number clearly labelled. Screenshots or images must be **clear and easy to read**.

**(1 mark)**

## Task 4 – rollercoaster



A rollercoaster is a fast-moving thrill ride with twists and loops.

A warning sub-system is required to indicate to operators that the carriage is about to start its descent from the top of the rollercoaster track.

An electronic engineer has designed the flowchart and circuit shown on the next page as a possible solution for the warning sub-system. The pin numbers used to connect the circuit to the microcontroller are shown in the table on the next page.

## Task 4 – rollercoaster (continued)

Input connection	Pin	Output connection
	7	buzzer
	4	LED
reset switch	1	
set switch	0	

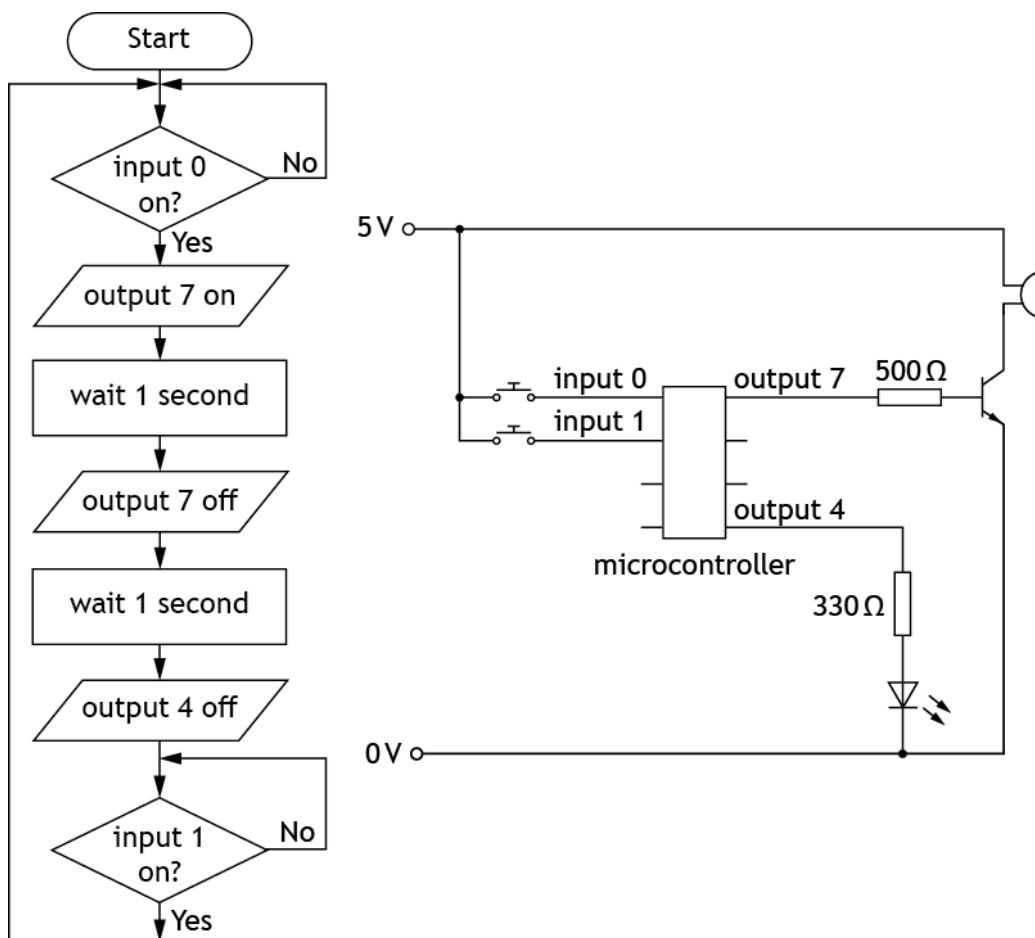

- 4a Simulate or construct the flowchart sequence and electronic circuit integrated together as shown.

A microcontroller of an alternative size may be used but **the pin numbers must match the connections given.**

You must present your evidence on A4 single-sided pages, with the task number clearly labelled. Screenshots or images must be **clear and easy to read.**

(5 marks)

## Task 4 – rollercoaster (continued)

The warning sub-system in task 4a is to be operated by the microcontroller using the following specification:

- i. When the set switch is activated a buzzer sounds three times.
- ii. Once the buzzer has sounded an LED turns on.
- iii. When the reset switch is activated the LED turns off and the sequence repeats.

**Errors in the flowchart in task 4a were found during testing.**

- 4b Complete the testing table on **worksheet 4b**, by carrying out the given planned tests and describing each initial test result.

**Amend the flowchart as necessary to meet the specification and complete each test again.** Describe the result of any amended flowchart test before moving onto the next test.

You must present your evidence on A4 single-sided pages, with the task number clearly labelled.

**(6 marks)**

- 4c Your amended flowchart and electronic circuit should now **meet the specification** given for the warning sub-system.

Present the evidence of your **amended flowchart and electronic circuit integrated together**, on A4 single-sided pages, with the task number clearly labelled. Screenshots or images **must be clear and easy to read.**

**(3 marks)**

- 4d Produce high-level microcontroller code to fully match your amended flowchart from **task 4c.**

You must present your evidence on A4 single-sided pages, with the task number clearly labelled. Screenshots or images must be **clear and easy to read.**

**(1 mark)**

## Task 4 – rollercoaster (continued)

- 4e Evaluate the performance of your final amended solution from **task 4c** against the specification given for the warning sub-system by completing the table on **worksheet 4e**.

You must:

- ◆ state if each specification point was met
- ◆ describe the performance of your amended solution in meeting each of the three specification points
- ◆ suggest one improvement that could be made to your amended solution and explain why it would improve the performance of the warning system for the operators of a real rollercoaster

You must present your evidence on A4 single-sided pages, with the task number clearly labelled.

**(4 marks)**

## Task 5 – aerial chair ride



chair support cables

In the aerial chair ride, riders are secured and then spun around at a high speed.

The speed of a motor used in the outdoor aerial chair ride needs to be increased. A gear train is required that will meet the following specification:

- i. Increase the speed of the motor by at least a factor of four, but not greater than eight.
- ii. The output gear must rotate in the same direction as the input gear.

5a Design a gear train on **worksheet 5a** (based on the gear sizes available to you) that will meet the specification. You must label the input gear and include all gear sizes.

**You must not construct or use simulation software to complete task 5a.**

You must present your evidence on A4 single-sided pages, with the task number clearly labelled.

**(2 marks)**

5b Simulate or construct your design from **task 5a**. You must include an input component to allow for testing and **label all gear sizes**.

You must present your evidence on A4 single-sided pages, with the task number clearly labelled. Screenshots or images must be **clear and easy to read**.

**(2 marks)**

## Task 5 – aerial chair ride (continued)

5c Complete the testing table on **worksheet 5c** by:

- ◆ entering the results of the observed input and output speeds for the gear system during simulation or after construction
- ◆ calculating the actual velocity ratio using your recorded values for the input and output speeds

You must present your evidence on A4 single-sided pages, with the task number clearly labelled.

**(2 marks)**

5d Evaluate the performance of your solution from **tasks 5b and 5c** against the given specification by completing the table on **worksheet 5d**. You should:

- ◆ state if each specification point was met
- ◆ describe the performance of your solution against both specification points

You must present your evidence on A4 single-sided pages, with the task number clearly labelled.

**(2 marks)**

## Task 5 – aerial chair ride (continued)

Two different materials were considered for the chair support cables on the aerial chair ride which will be suitable for use outdoors.

The characteristics of the materials considered are shown in the table below.

Characteristic	Material A	Material B
resistance to corrosion	high	low
tensile strength	low	high
compressive strength	high	low

Material B was selected for the chair support cables.

- 5e Describe on **worksheet 5e**, one advantage and one disadvantage of material B as the choice for the chair support cables. Make reference to the characteristics in the given table.

You must present your evidence on A4 single-sided pages, with the task number clearly labelled.

**(2 marks)**

**[END OF ASSIGNMENT]**

The logo for National 5, featuring the letters 'N5' in a large, bold, white font on a purple square background.

National 5  
Coursework  
Assessment Task



---

# National 5 Engineering Science Assignment Assessment task: theme park

## Worksheets

Valid for session 2019-20 only.
---------------------------------

## Worksheet 1a

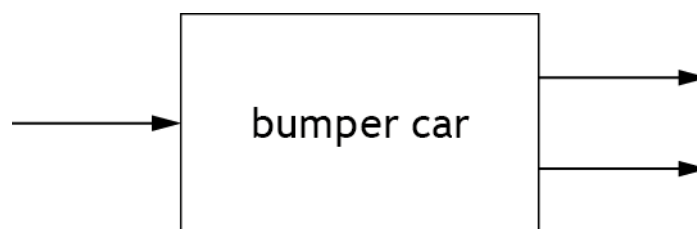

(2 marks)

Name:	
Date of birth:	
Scottish Candidate Number (SCN):	
Centre name:	
Centre number:	

## Worksheet 1b

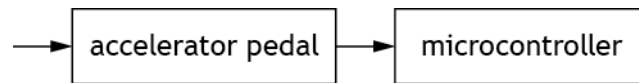

(6 marks)

Name:	
Date of birth:	
Scottish Candidate Number (SCN):	
Centre name:	
Centre number:	

## Worksheet 2a

up position

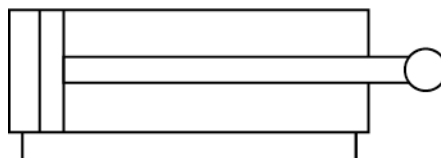

(6 marks)

Name:	
Date of birth:	
Scottish Candidate Number (SCN):	
Centre name:	
Centre number:	

## Worksheet 2b

Specification point	Planned test	Expected result
i		
ii and iii	Actuate the second 3/2 valve.	

(3 marks)

Name:	
Date of birth:	
Scottish Candidate Number (SCN):	
Centre name:	
Centre number:	

## Worksheet 3a

safety  
barrier 

start  
switch 

emergency  
stop  
button 

 motor

(3 marks)

Name:	
Date of birth:	
Scottish Candidate Number (SCN):	
Centre name:	
Centre number:	

## Worksheet 4b

Planned test	Expected result	Initial test result	Amended test result
<b>Test 1a</b> Press the set switch.	The buzzer should sound three times.		
<b>Test 1b</b> Press the set switch.	Once buzzer has sounded the LED should turn on.		
<b>Test 2</b> Press the reset switch.	The LED should turn off and the system should repeat.		

(6 marks)

Name:	
Date of birth:	
Scottish Candidate Number (SCN):	
Centre name:	
Centre number:	

## Worksheet 4e

Specification point	Met? Yes/No	Description of performance
i		
ii		
iii		

Suggested improvement	
Explanation for improvement	

(4 marks)

Name:	
Date of birth:	
Scottish Candidate Number (SCN):	
Centre name:	
Centre number:	

## Worksheet 5a

(2 marks)

Name:	
Date of birth:	
Scottish Candidate Number (SCN):	
Centre name:	
Centre number:	

## Worksheet 5c

Planned test	Input speed	Output speed	Required velocity ratio	Actual velocity ratio
Measure the input speed and output speed of the gear system and calculate the actual velocity ratio.			Between 1:4 and 1:8 (0.25:1 and 0.125:1)	

(2 marks)

Name:	
Date of birth:	
Scottish Candidate Number (SCN):	
Centre name:	
Centre number:	

## Worksheet 5d

Specification point	Met? Yes/No	Description of performance
i		
ii		

(2 marks)

Name:	
Date of birth:	
Scottish Candidate Number (SCN):	
Centre name:	
Centre number:	

## Worksheet 5e

<b>Advantage of material B</b>	
<b>Disadvantage of material B</b>	

(2 marks)

Name:	
Date of birth:	
Scottish Candidate Number (SCN):	
Centre name:	
Centre number:	

*Acknowledgement of copyright*

Task 1 – A\_Lesik/Shutterstock.com

Task 3 – Nigel Jarvis/Shutterstock.com

Task 4 – Tim Gouw/Pexel.com

Task 5 – dwphotos/Shutterstock.com

## Administrative information

---

Published: January 2020 (version 1.0)

---

### History of changes

Version	Description of change	Date

## Security and confidentiality

This document can be used by practitioners in SQA approved centres for the assessment of National Courses and not for any other purpose.

This document may only be downloaded from SQA's designated secure website by authorised personnel.

© Scottish Qualifications Authority 2020