

The logo for National 5, featuring the letters 'N5' in a large, white, sans-serif font inside a purple square.

National 5  
Coursework  
Assessment Task



---

# National 5 Engineering Science Assignment Finalised Marking Instructions

© Scottish Qualifications Authority 2020

These marking instructions are prepared by examination teams for use by SQA appointed markers when marking external course assessments.

Please note, although we were not able to carry out live marking in 2020, these marking instructions are presented in a final state and have been referenced against limited candidate responses.

The information in this document may be reproduced in support of SQA qualifications only on a non-commercial basis. If it is reproduced, SQA must be clearly acknowledged as the source. If it is to be reproduced for any other purpose, written permission must be obtained from [permissions@sqa.org.uk](mailto:permissions@sqa.org.uk).

# Marking instructions

## General marking principles

This information is provided to help you understand the general principles that must be applied when marking candidate responses in this assignment. These principles must be read in conjunction with the detailed/specific marking instructions, which identify the key features required in candidate responses.

- a Marks for each candidate response must always be assigned in line with these general marking principles and the specific marking instructions for this assessment.
- b Marking should always be positive. This means that, for each candidate response, marks are accumulated for the demonstration of relevant skills, knowledge and understanding: they are not deducted from a maximum on the basis of errors or omissions.
- c If a specific candidate response is not covered by either the general marking principles or detailed marking instructions, you must seek guidance from your team leader.

Task		Expected response	Max mark	Additional guidance
1.	a	<pre> graph LR     UI[user input] --&gt; BC[bumper car]     BC --&gt; M[movement]     BC --&gt; L[light] </pre>	2	<ul style="list-style-type: none"> <li>User input / action identified and in the correct position (1 mark)</li> </ul> <p>Accept kinetic as input</p> <ul style="list-style-type: none"> <li>Light and movement outputs identified and in the correct position (1 mark)</li> </ul> <p>Accept kinetic / (desired) speed as output</p> <p>Do not accept input or output components</p> <p>Ignore extra boxes or words.</p> <p>If no arrows shown assume left to right.</p>

Task	Expected response	Max mark	Additional guidance
1. b	<pre> graph LR     subgraph SystemBoundary [ ]         direction LR         AP[accelerator pedal] --&gt; MC[microcontroller]         MC --&gt; D1[driver]         MC --&gt; D2[driver]         D1 --&gt; M[motor]         D2 --&gt; LED[LED]         M --&gt; MS[speed sensor]         MS --&gt; MC     end     UI[user input] --&gt; AP     M --&gt; MOV[movement]     LED --&gt; L[light] </pre>	6	<ul style="list-style-type: none"> <li>• Sensor (for measuring speed) connected directly to microcontroller (1 mark)</li> </ul> <p>Do not accept speedometer.</p> <ul style="list-style-type: none"> <li>• Feedback loop from motor <b>output</b> into microcontroller, with arrow-head (1 mark)</li> <li>• One driver per output device individually connected to microcontroller (1 mark)</li> <li>• Motor in output position (1 mark)</li> <li>• LED (strip) in output position (1 mark)</li> <li>• System boundary around sub-systems only <b>and</b> boxes around each sub-system <b>and</b> acceptable input and outputs stated in 1a for each device (1 mark)</li> </ul> <p>Allow FTE for input and outputs from 1a</p> <p>Do not accept an action (e.g. motor on)</p> <p>Ignore additional sub-systems.</p> <p>Ignore misplaced sensor sub-system.</p> <p>Ignore boxes around input/outputs.</p> <p>If no arrows shown assume left to right</p>

Task	Expected response	Max mark	Additional guidance
2. a		6	<p>Block diagram, circuit diagram (or a hybrid) or constructed/simulated.</p> <p>Components identified or implied (e.g. UDR) by name or symbols.</p> <p>Connections between components and valves must be shown. Ignore line types. Port to port piping is not required.</p> <ul style="list-style-type: none"> <li>• 5/2 valve with two connections to double acting cylinder (with outstroke direction identified if necessary) <b>(1 mark)</b></li> <li>• Uni-directional restrictor used to slow instroke of piston <b>(1 mark)</b></li> </ul> <p>Ignore orientation of uni-directional restrictor</p> <ul style="list-style-type: none"> <li>• 2 x 3/2 valves piped to 5/2 <b>(1 mark)</b></li> <li>• Solenoid actuator to cause outstroke <b>(1 mark)</b></li> </ul> <p>Do not accept “electrical” actuator</p> <ul style="list-style-type: none"> <li>• Any actuator to sense up position except push button, lever, pilot or spring return <b>(1 mark)</b></li> <li>• Reservoir before piston instrokes (on signal line between up position 3/2 and 5/2) <b>(1 mark)</b></li> </ul> <p>Ignore any time delay uni-directional restrictor</p>

Task		Expected response			Max mark	Additional guidance
2.	b				3	<p>Responses must be descriptive.</p> <ul style="list-style-type: none"> <li>• Test for (electrically) actuating / sending signal to electrical actuator/solenoid or 3/2 valve <b>(1 mark)</b></li> </ul> <p>Do not accept “actuator receives signal” on its own.</p> <ul style="list-style-type: none"> <li>• Result for piston outstroking <b>and</b> at full speed <b>(1 mark)</b></li> <li>• Result for after time delay (implied) <b>and</b> piston instroking <b>and</b> slowly/smoothly <b>(1 mark)</b></li> </ul> <p><b>Do not</b> apply FTE from candidate’s design / circuit in 2a</p>
		Specification point	Planned test	Expected result		
		i.	Actuate the electrical actuator / actuate the (first) 3/2 valve	The piston should outstroke at full speed.		
ii and iii.	Actuate the second 3/2 valve.	After a time delay the piston instrokes slowly.				

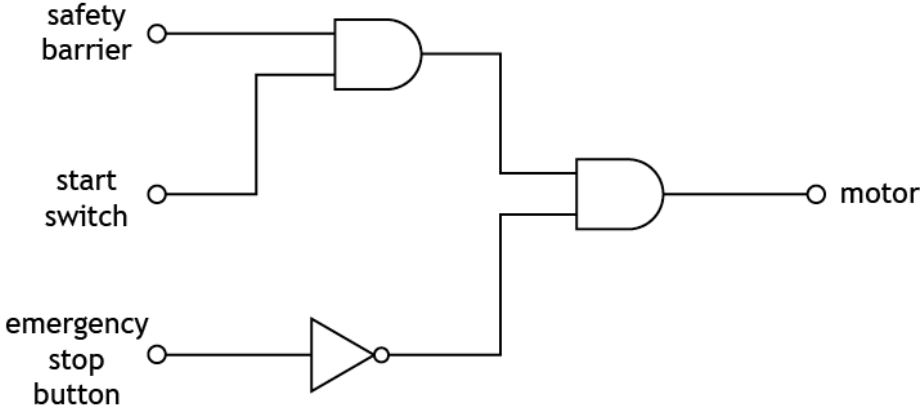
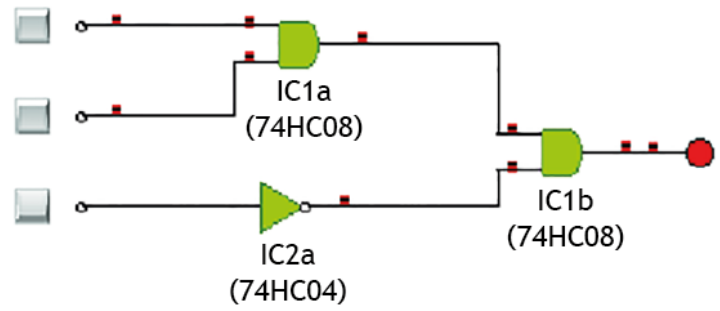
Task	Expected response	Max mark	Additional guidance
3. a		3	<ul style="list-style-type: none"> <li>• NOT gate connected to emergency stop button (1 mark)</li> <li>• AND gate connected to safety barrier and start switch (1 mark)</li> <li>• 2<sup>nd</sup> AND gate connected to first AND gate and (NOT) emergency stop button (1 mark)</li> </ul> <p>Accept alternative correct logic diagram</p> <p>If simulated/constructed (0 marks)</p> <p>If evidence is only provided for 3(b) then no marks can be awarded for design.</p>
b		1	<ul style="list-style-type: none"> <li>• Correctly connected logic gates (from design in 3a) with suitable input (and output) devices (1 mark)</li> </ul> <p>If constructed, IC numbers must be clearly labelled.</p>

Task	Expected response	Max mark	Additional guidance
4. a		5	<p><b>Electronic circuit</b></p> <ul style="list-style-type: none"> <li>all correct components selected and wiring attempted (1 mark)</li> <li>correct wiring, microcontroller pin numbers and connections, component orientations and component values (1 mark)</li> </ul> <p>If pin numbers are not visible on microcontroller refer to flowchart</p> <p>Allow use of alternative microcontrollers other than 8-pin</p> <p>If electronic circuit constructed allow use of alternative pin numbers appropriate to hardware used</p> <p><b>Flowchart</b></p> <ul style="list-style-type: none"> <li>correct symbols (to the software) with feedback loops exactly as shown (1 mark)</li> <li>all correct pin numbers (FTE from circuit), pin states, decisions and time delays (1 mark)</li> </ul> <p><b>Integration</b></p> <ul style="list-style-type: none"> <li>flowchart and electronic circuit (1 mark)</li> </ul>

Task		Expected response				Max mark	Additional guidance
4.	b					6	<p>Do not accept direct copy from Expected Results as Amended Test Result.</p> <p>Accept correct pin numbers in place of components.</p> <p><b>Test 1a</b></p> <ul style="list-style-type: none"> <li>• Identification of buzzer sounding/on and number of times (apply FTE from 4a) (1 mark)</li> <li>• Description of correct amended result (or apply FTE from 4c) (1 mark)</li> </ul> <p><b>Test 1b</b></p> <ul style="list-style-type: none"> <li>• Identification of buzzer sounding/on and LED not turning on (apply FTE from 4a) (1 mark)</li> <li>• Description of correct amended result referring to both buzzer and LED (or apply FTE from 4c) (1 mark)</li> </ul> <p><b>Test 2</b></p> <ul style="list-style-type: none"> <li>• Identification of LED not turning off and system repeating / looping back to start (apply FTE from test 1b results and/or 4a and/or 4c) (1 mark)</li> <li>• Description of correct amended result referring to both LED and system repeating (or apply FTE from 4c) (1 mark)</li> </ul>
		<b>Planned test</b>	<b>Expected result</b>	<b>Initial test result</b>	<b>Amended test result</b>		
		<b>Test 1a</b> Press the set switch.	The buzzer should sound 3 times.	Buzzer only sounds once.	The buzzer sounds 3 times.		
		<b>Test 1b</b> Press the set switch.	Once buzzer has sounded the LED should turn on.	After the buzzer sounds the LED does not turn on.	After the buzzer sounds the LED turns on.		
<b>Test 2</b> Press the reset switch.	The LED should turn off and the system should repeat.	LED does not turn off but the system repeats.	The LED turns off and the system repeats.				

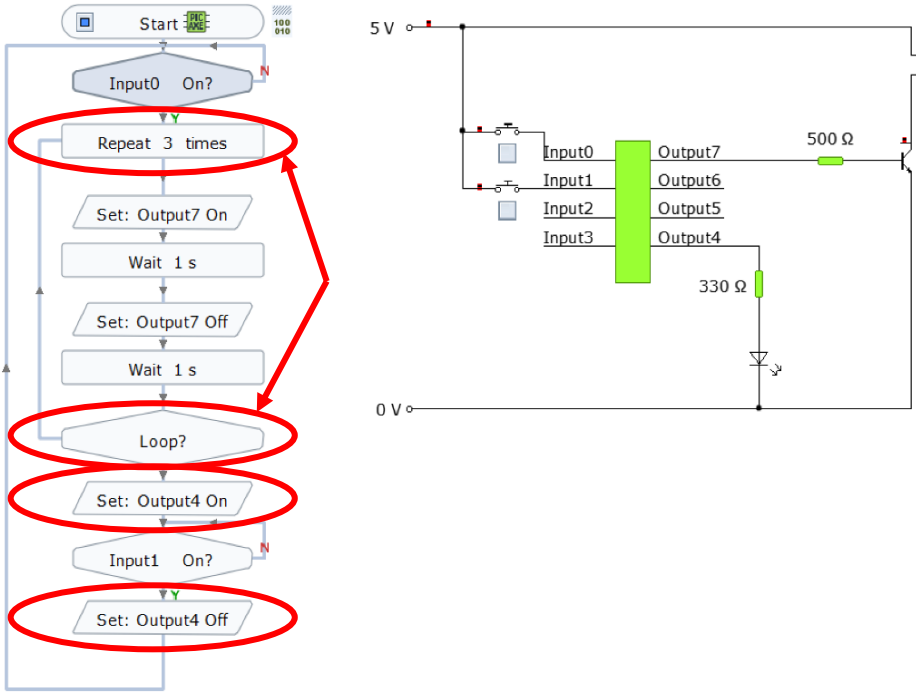
Task	Expected response	Max mark	Additional guidance
4. c		3	<p><b>Test 1a amendment</b></p> <ul style="list-style-type: none"> <li>• Addition of repeating 3 times, to achieve buzzer pulsing on and off, in correct position (1 mark)</li> </ul> <p>Apply FTE for amendment(s) to flowchart and/or circuit to meet Amended Test (1a) Result in 4b.</p> <p><b>Test 1b amendment</b></p> <ul style="list-style-type: none"> <li>• Correction of output 4 off to on / addition of output 4 on (between output 7 on and input 1 decision) (1 mark)</li> </ul> <p>Apply FTE for amendment(s) to flowchart and/or circuit to meet Amended Test (1b) Result in 4b.</p> <p><b>Test 2 amendment</b></p> <ul style="list-style-type: none"> <li>• Output 4 off in appropriate position (bottom or top of flowchart). (1 mark)</li> </ul> <p>Apply FTE for amendment(s) to flowchart and/or circuit to meet Amended Test (2) Result in 4b.</p> <p>Ignore any additional steps.</p>

Task		Expected response	Max mark	Additional guidance
4.	d	<pre> label0:     if Input0 = 1 then label1     goto label0 label1:     let loop1 = 3     do         high 7         pause 1000         low 7         pause 1000         let loop1 = loop1 - 1     loop while loop1 &gt; 0     high 4 label2:     if Input1 = 1 then label3     goto label2 label3:     low 4     goto label0 </pre>	1	<ul style="list-style-type: none"> <li>Correct code and pin numbers to fully match the candidate's final flowchart (1 mark)</li> </ul> <p>Accept manually written, automatically generated or a hybrid.</p> <p>Any high level language acceptable.</p>

Task		Expected response			Max mark	Additional guidance
4.	e	Spec point	Met? Y/N	Description of performance	4	<p>Responses must be based on evidence from 4b. In absence of 4b refer to 4c.</p> <ul style="list-style-type: none"> <li>State whether specification point i was met with description referring to (set) switch <b>and</b> buzzer sounding <b>and</b> number of times (1 mark)</li> <li>State whether specification point ii was met with description referring to the LEDs operation <b>after</b> the buzzer has sounded (1 mark)</li> <li>State whether specification point iii was met with description referring to reset switch <b>and</b> LED operation <b>and</b> system repeating (1 mark)</li> <li>Appropriate justification of suggested improvement to the circuit or flowchart. Must refer to why this is an improvement for the operators (stated or implied). (1 mark)</li> </ul> <p>Do not accept “people” / “person” on its own.</p> <p>Do not accept removal of human error as an explanation for improvement.</p>
		i.	Y	When the set switch was pressed the buzzer did sound 3 times.		
		ii.	Y	After the buzzer has sounded the LED turned on.		
		iii.	Y	After the reset switch was pressed the LED turned off and the system looped back to the start.		
		Suggested improvement	Make the buzzer sound more times / increase the length of the delays / make it sound continuously. Have LED flash (at same time as buzzer).			
Explanation for improvement	Gives the operators more warning. More noticeable indicator for the operators (if it is noisy).					

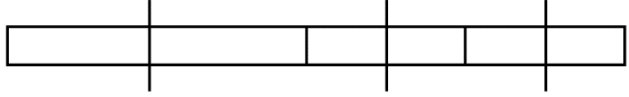
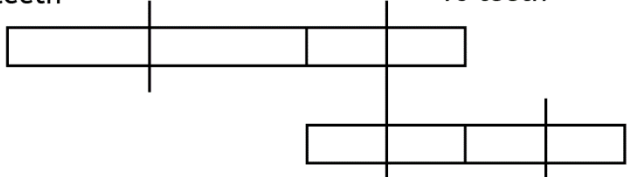
Task		Expected response	Max mark	Additional guidance
5.	a	<p>input 40 teeth                      idler gear 10 teeth                      output 10 teeth</p>  <p>input 40 teeth                      10 teeth</p>  <p>10 teeth                      output 10 teeth</p>	2	<p>If simulated/constructed (0 marks)</p> <ul style="list-style-type: none"> <li>Any gear train that would allow the input and output to turn in same direction. (1 mark)</li> <li>All (gear) sizes shown plus labelling input or implied (for example through inclusion of motor or calculations or output labelled) that will give a speed increase of at least a factor of 4, but no greater than 8 (1 mark)</li> </ul>

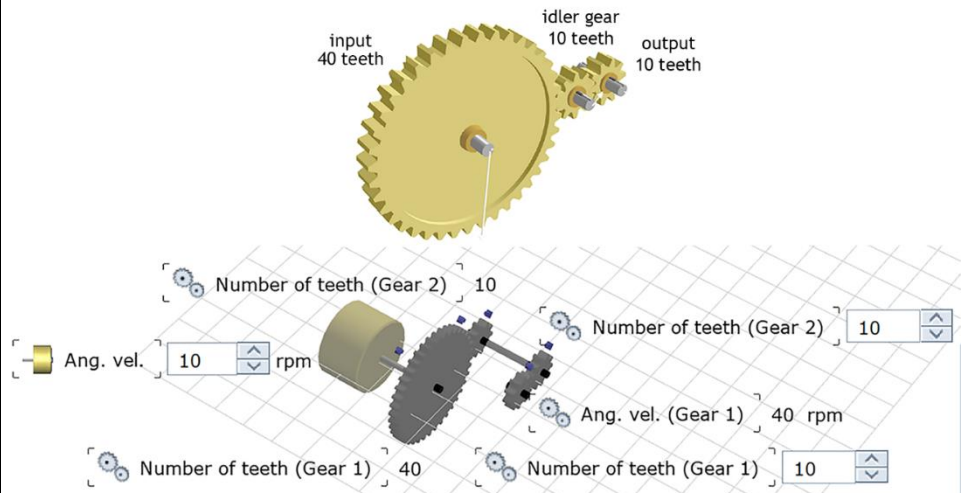
Task		Expected response	Max mark	Additional guidance
5.	b		2	<ul style="list-style-type: none"> <li>• Gear train simulated or constructed. (1 mark)</li> </ul> <p>Apply FTE from 5a for alternative drive systems.</p> <ul style="list-style-type: none"> <li>• All (gear) sizes shown, to match the design in task 5a or evidence of velocity ratio (for example graph) that proves teeth numbers. (1 mark)</li> </ul> <p>If a simple gear train has been designed in 5a, accept a compound gear train simulation for 5b providing velocity ratio is the same as 5a.</p>

Task		Expected response				Max mark	Additional guidance							
5.	c	<table border="1"> <thead> <tr> <th>Planned test</th> <th>Input speed</th> <th>Output speed</th> <th>Required velocity ratio</th> <th>Actual velocity ratio</th> </tr> </thead> <tbody> <tr> <td>Measure the input speed and output speed of the gear system and calculate the actual velocity ratio.</td> <td>10 revs min<sup>-1</sup> or 10 turns</td> <td>40 revs min<sup>-1</sup> or 40 turns</td> <td>Between 1:4 and 1:8  (0.25:1 and 0.125:1)</td> <td>1:4  (0.25:1)</td> </tr> </tbody> </table>	Planned test	Input speed	Output speed	Required velocity ratio	Actual velocity ratio	Measure the input speed and output speed of the gear system and calculate the actual velocity ratio.	10 revs min <sup>-1</sup> or 10 turns	40 revs min <sup>-1</sup> or 40 turns	Between 1:4 and 1:8  (0.25:1 and 0.125:1)	1:4  (0.25:1)	2	<p><b>Input/output speeds</b></p> <ul style="list-style-type: none"> <li>Complete table showing input speed and correct output speed for teeth numbers given in 5b. (1 mark)</li> </ul> <p>If no teeth numbers indicated on 5b refer to 5a.</p> <p>No evidence of simulation/construction in 5b. (0 mark)</p> <p>Units not required.</p> <p><b>Velocity ratio</b></p> <ul style="list-style-type: none"> <li>Correct ratio/value for given input and output values (1 mark)</li> </ul> <p>If no input or output speeds have been entered VR should be checked against evidence from 5b, or, in absence of 5b, design in 5a.</p>
Planned test	Input speed	Output speed	Required velocity ratio	Actual velocity ratio										
Measure the input speed and output speed of the gear system and calculate the actual velocity ratio.	10 revs min <sup>-1</sup> or 10 turns	40 revs min <sup>-1</sup> or 40 turns	Between 1:4 and 1:8  (0.25:1 and 0.125:1)	1:4  (0.25:1)										

Task		Expected response			Max mark	Additional guidance							
5.	d	<table border="1"> <thead> <tr> <th>Spec point</th> <th>Met? Y/N</th> <th>Description of performance</th> </tr> </thead> <tbody> <tr> <td>i.</td> <td>Y</td> <td>The output speed is 4 times faster (which is at least a factor of 4 but not more than 8). The velocity ratio is 1:4 (which is within the required range).</td> </tr> <tr> <td>ii.</td> <td>Y</td> <td>The input gear and output gear both turn in the same direction.</td> </tr> </tbody> </table>	Spec point	Met? Y/N	Description of performance	i.	Y	The output speed is 4 times faster (which is at least a factor of 4 but not more than 8). The velocity ratio is 1:4 (which is within the required range).	ii.	Y	The input gear and output gear both turn in the same direction.	2	<p><b>Specification i</b> Evaluation should be based on evidence provided in 5c, or in its absence 5b, or in its absence design in 5a.</p> <ul style="list-style-type: none"> <li>State whether specification point i was met with description referring to (output) speed <b>and</b> speed increase by factor of 4 to 8 (must be a numerical aspect) <b>or</b> description including VR value (1:4 to 1:8) <b>(1 mark)</b></li> </ul> <p><b>Specification ii</b> Evaluation should be based on evidence provided in 5b, or in its absence design in 5a.</p> <ul style="list-style-type: none"> <li>State whether specification point ii was met with description referring to direction of rotation <b>and</b> input <b>and</b> output <b>(1 mark)</b></li> </ul> <p>Accept “both” / “they” as referring to input <b>and</b> output</p>
Spec point	Met? Y/N	Description of performance											
i.	Y	The output speed is 4 times faster (which is at least a factor of 4 but not more than 8). The velocity ratio is 1:4 (which is within the required range).											
ii.	Y	The input gear and output gear both turn in the same direction.											

Task		Expected response	Max mark	Additional guidance				
5.	e	<table border="1"> <tr> <td style="background-color: #cccccc;">Advantage of material B</td> <td> <p>High tensile strength</p> <p>Cables less likely to fail/ The cables will be in tension/ The ride will be safer</p> </td> </tr> <tr> <td style="background-color: #cccccc;">Disadvantage of material B</td> <td> <p>Low corrosion resistance</p> <p>The cables will require (more) maintenance / The cables will be outdoors/ Rust could get onto the user's hands/ The cables will get weaker (over time)</p> </td> </tr> </table>	Advantage of material B	<p>High tensile strength</p> <p>Cables less likely to fail/ The cables will be in tension/ The ride will be safer</p>	Disadvantage of material B	<p>Low corrosion resistance</p> <p>The cables will require (more) maintenance / The cables will be outdoors/ Rust could get onto the user's hands/ The cables will get weaker (over time)</p>	2	<p>Do not accept any response relating to compressive strength.</p> <p>Accept “they” or “it” as referring to the cables.</p> <ul style="list-style-type: none"> <li>State characteristic (high tensile strength) <b>and</b> describe advantage / comparison of materials <b>within context</b> of cables / ride / users / theme park staff (1 mark)</li> </ul> <p>Accept tension as being implied.</p> <p>Do not accept “cables will be stronger/durable” on its own.</p> <ul style="list-style-type: none"> <li>State characteristic (low corrosion resistance) <b>and</b> describe disadvantage / comparison of materials <b>within context</b> of cables / ride / users / theme park staff (1 mark)</li> </ul> <p>Do not accept “cables will rust / fail” on its own.</p>
Advantage of material B	<p>High tensile strength</p> <p>Cables less likely to fail/ The cables will be in tension/ The ride will be safer</p>							
Disadvantage of material B	<p>Low corrosion resistance</p> <p>The cables will require (more) maintenance / The cables will be outdoors/ Rust could get onto the user's hands/ The cables will get weaker (over time)</p>							

[END OF MARKING INSTRUCTIONS]