



National
Qualifications
2018

X813/75/02

**Chemistry
Section 1 — Questions**

MONDAY, 21 MAY

1:00 PM – 3:30 PM

Instructions for completion of Section 1 are given on *page 02* of your question and answer booklet X813/75/01.

Record your answers on the answer grid on *page 03* of your question and answer booklet.

You may refer to the Chemistry Data Booklet for National 5.

Before leaving the examination room you must give your question and answer booklet to the Invigilator; if you do not, you may lose all the marks for this paper.



* X 8 1 3 7 5 0 2 *

SECTION 1 — 25 marks

Attempt ALL questions

1. Which of the following changes would **not** speed up a chemical reaction?

- A Increasing the particle size
- B Increasing the temperature
- C Increasing the concentration
- D Addition of a catalyst

2. Which line in the table identifies the correct location of a proton and an electron in an atom?

	<i>Proton</i>	<i>Electron</i>
A	inside the nucleus	inside the nucleus
B	inside the nucleus	outside the nucleus
C	outside the nucleus	outside the nucleus
D	outside the nucleus	inside the nucleus

3. Which of the following elements does **not** exist as diatomic molecules?

- A Oxygen
- B Helium
- C Bromine
- D Hydrogen

4. The shapes of some molecules are shown below.

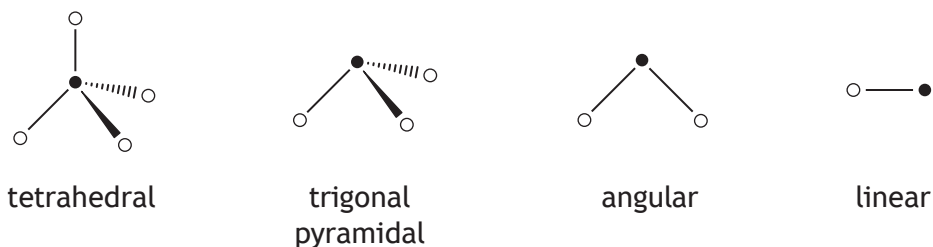

The shape of a molecule of hydrogen bromide is likely to be

- A tetrahedral
- B trigonal pyramidal
- C angular
- D linear.

5. Which of the following elements forms an ion with a single positive charge and an electron arrangement of 2,8?

You may wish to use the data booklet to help you.

- A Sodium
- B Magnesium
- C Fluorine
- D Neon

6. Which line in the table shows the properties of a covalent network compound?

	Melting point (°C)	Boiling point (°C)	Conducts electricity	
			Solid	Liquid
A	-127	-100	no	no
B	795	1410	no	yes
C	30	2204	yes	yes
D	2700	3350	no	no

7. 0.1 mol of sodium hydroxide was dissolved in water and the solution made up to 250 cm³. What is the concentration, in mol l⁻¹, of the sodium hydroxide solution?

- A 0.0004
- B 0.025
- C 0.4
- D 2.5

8. An alkaline solution contains

- A only hydroxide ions
- B more hydroxide ions than hydrogen ions
- C more hydrogen ions than hydroxide ions
- D equal numbers of hydrogen ions and hydroxide ions.

[Turn over

9. A student made some statements about the effect of adding water to an acidic solution. Identify the correct statement.

- A The pH of the solution will remain the same.
- B The pH of the solution will decrease.
- C The hydrogen ion concentration will decrease.
- D The hydrogen ion concentration will increase.

10. The shortened structural formula for a compound is



Which of the following is another way of representing this structure?

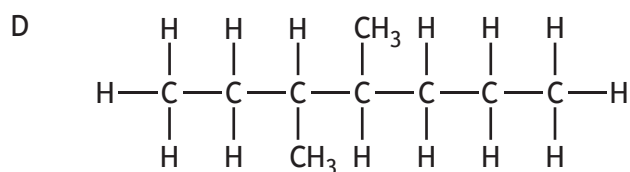
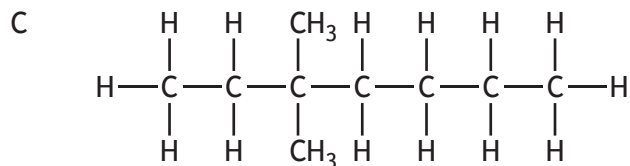
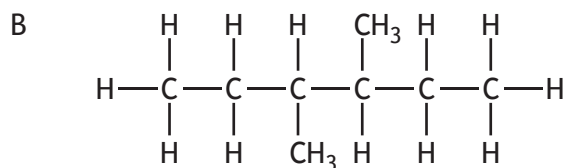
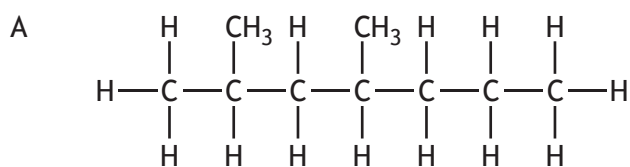

12. Which of the following reactions takes place when an alcohol is formed from an alkene?

- A Hydrogenation
- B Combustion
- C Hydration
- D Reduction

13.

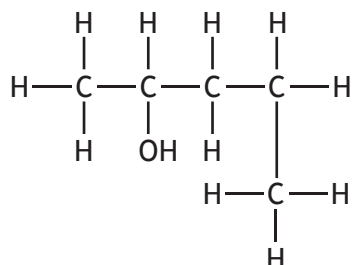

The systematic name for the above compound is

- A pentan-2-ol
 - B pentan-4-ol
 - C 1-methylbutan-3-ol
 - D 4-methylbutan-2-ol.
14. Which of the following alcohols is the least soluble in water?
- A Butan-1-ol
 - B Hexan-1-ol
 - C Pentan-1-ol
 - D Propan-1-ol

15. A student set up an experiment to determine the quantity of energy released when a hydrocarbon burns.
- Which of the following diagrams shows the apparatus which would produce the most accurate result?

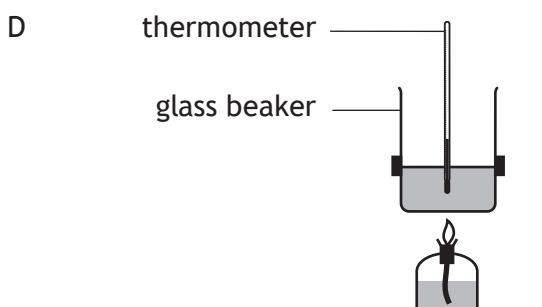
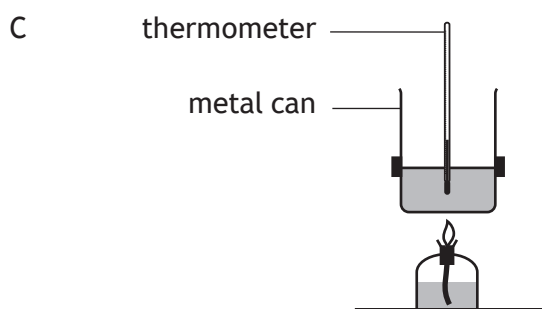
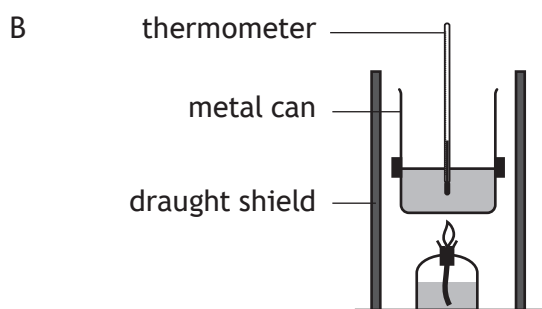
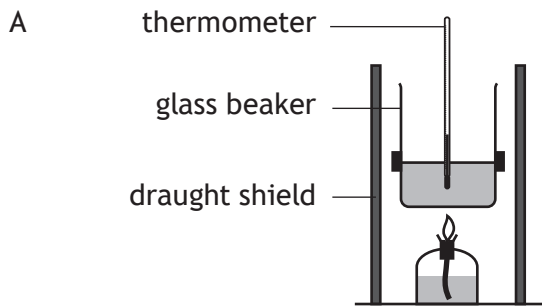

[Turn over

16. The ether, 1-ethoxypropane, can be made by the Williamson reaction.

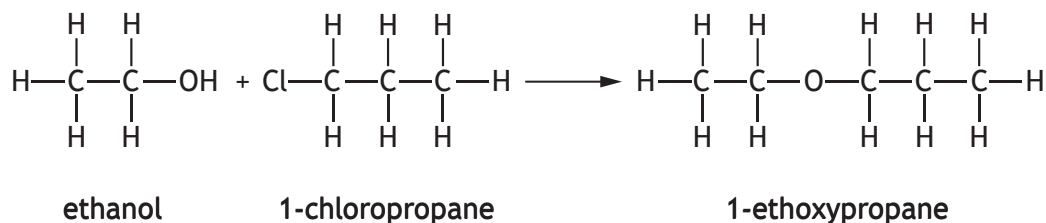

The structural formula for another ether is shown below.

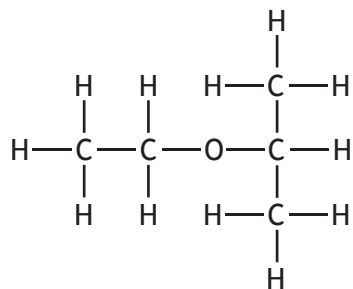

2-ethoxypropane

Which of the following pairs of compounds would react together to produce 2-ethoxypropane?

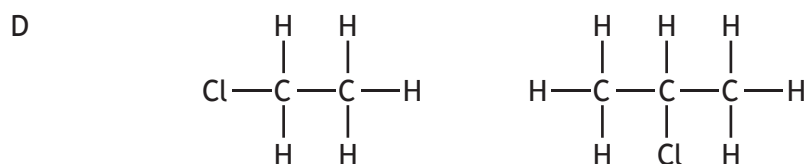
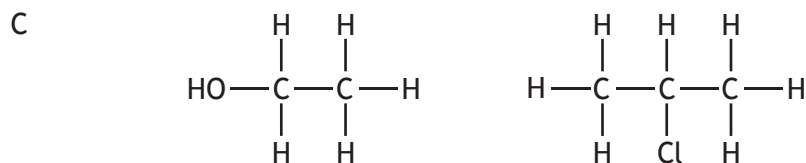
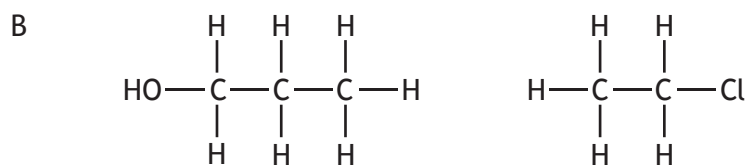
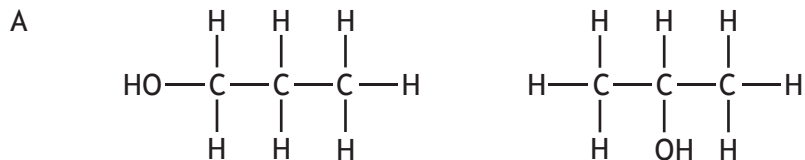

17. Information about the reactions of four different metals, W, X, Y and Z is given in the table.

<i>Metal</i>	<i>Reaction with dilute acid</i>	<i>Reaction with water</i>
W	moderate reaction	no reaction
X	fast reaction	slow reaction
Y	slow reaction	no reaction
Z	fast reaction	no reaction

The order of reactivity of the metals, starting with the most reactive is

- A X, Z, W, Y
- B Y, W, Z, X
- C Z, X, W, Y
- D Y, W, X, Z.

18. The ion-electron equations for the oxidation and reduction steps in the reaction between hydrogen and oxygen are given below.



The redox equation for the overall reaction is

- A $\text{H}_2(\text{g}) + 2\text{H}_2\text{O}(\ell) + \text{O}_2(\text{g}) + 4\text{e}^- \rightarrow 2\text{H}^+(\text{aq}) + 4\text{OH}^-(\text{aq}) + 2\text{e}^-$
- B $2\text{H}_2(\text{g}) + 2\text{H}_2\text{O}(\ell) + \text{O}_2(\text{g}) \rightarrow 4\text{H}^+(\text{aq}) + 4\text{OH}^-(\text{aq})$
- C $\text{H}_2(\text{g}) + 2\text{H}_2\text{O}(\ell) + \text{O}_2(\text{g}) \rightarrow 2\text{H}^+(\text{aq}) + 4\text{OH}^-(\text{aq})$
- D $2\text{H}_2(\text{g}) + 2\text{H}_2\text{O}(\ell) + \text{O}_2(\text{g}) + 4\text{e}^- \rightarrow 4\text{H}^+(\text{aq}) + 4\text{OH}^-(\text{aq}) + 4\text{e}^-$

[Turn over

19. Which of the following metals, when connected to lead in a cell, would produce the highest reading on the voltmeter?

You may wish to use the data booklet to help you.

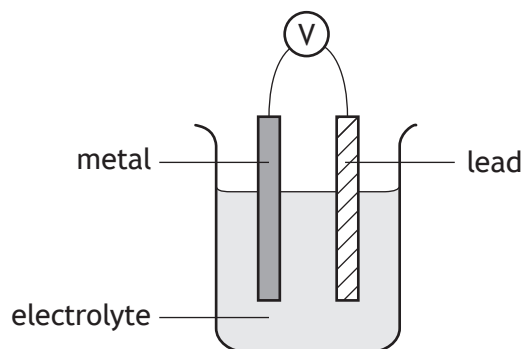

- A Zinc
 - B Tin
 - C Nickel
 - D Lead
20. Which of the following salts would **not** be used as a fertiliser?
- A Ammonium chloride
 - B Ammonium phosphate
 - C Sodium chloride
 - D Sodium phosphate

21. Which metal is used as the catalyst in the industrial manufacture of ammonia?

- A Nickel
- B Platinum
- C Iron
- D Rhodium

22. The diagram shows the path of two different types of radiation as they pass through an electric field.

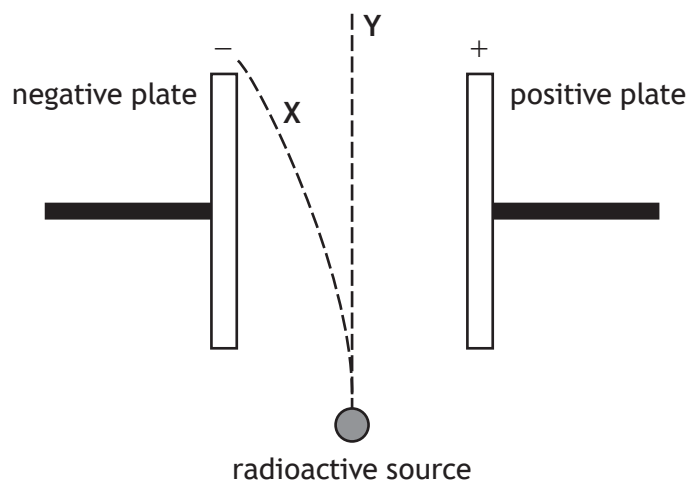

Which line in the table correctly identifies the types of radiation which follow paths X and Y?

	<i>Path X</i>	<i>Path Y</i>
A	alpha	beta
B	beta	alpha
C	beta	gamma
D	alpha	gamma

23. Metallic bonding is a force of attraction between

- A a shared pair of electrons and two nuclei
- B negative ions and delocalised electrons
- C negative ions and positive ions
- D positive ions and delocalised electrons.

[Turn over

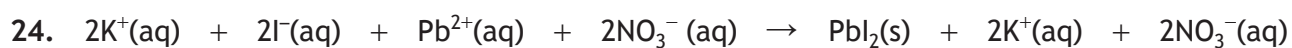

The type of reaction represented by this equation is

- A neutralisation
- B precipitation
- C addition
- D redox.

25. A student prepared a sample of copper sulfate crystals by reacting excess copper carbonate with acid.

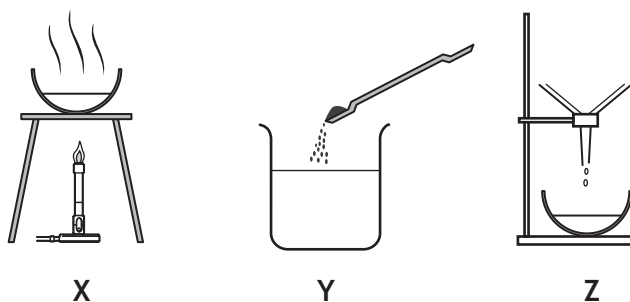

Which line in the table shows the correct order in which this experiment would be carried out?

- A Y, X, Z
- B X, Y, Z
- C Z, Y, X
- D Y, Z, X

[END OF SECTION 1. NOW ATTEMPT THE QUESTIONS IN SECTION 2 OF YOUR QUESTION AND ANSWER BOOKLET]