



FOR OFFICIAL USE

--	--	--	--	--	--

National Qualifications

Mark

--

X807/75/01

Biology  
Section 1 — Answer grid  
and Section 2

Duration — 2 hours 30 minutes



Fill in these boxes and read what is printed below.

Full name of centre

--

Town

--

Forename(s)

--

Surname

--

Number of seat

--

Date of birth

Day

--	--

Month

--	--

Year

--	--

Scottish candidate number

--	--	--	--	--	--	--	--	--	--

Total marks — 100

SECTION 1 — 25 marks

Attempt ALL questions.

Instructions for the completion of Section 1 are given on *page 02*.

SECTION 2 — 75 marks

Attempt ALL questions.

Write your answers clearly in the spaces provided in this booklet. Additional space for answers and rough work is provided at the end of this booklet. If you use this space you must clearly identify the question number you are attempting. Any rough work must be written in this booklet. Score through your rough work when you have written your final copy.

Use **blue** or **black** ink.

Before leaving the examination room you must give this booklet to the Invigilator; if you do not, you may lose all the marks for this paper.



SECTION 2 — 75 marks

Attempt ALL questions

MARKS  
DO NOT WRITE IN THIS MARGIN

1. The diagram shows a typical green plant cell and some of its structures.



- (a) (i) Using a letter from the diagram, identify one structure that would also be found in an animal cell. 1

Letter \_\_\_\_\_

- (ii) Choose one structure labelled in the diagram and state its function. 1

Letter \_\_\_\_\_

Function \_\_\_\_\_

\_\_\_\_\_

- (b) The table shows different types of cells and their average cell width.

Cell type	Average cell width ( $\mu\text{m}$ )
onion epidermis	201
human liver	20
human egg	130
yeast	8
<i>Bacillus</i> bacterium	3

Calculate how many times wider an onion epidermis cell is than a *Bacillus* bacterium cell. 1

Space for calculation

\_\_\_\_\_



2. Pieces of beetroot and rhubarb tissue were placed in different concentrations of sugar solution. After 30 minutes, the number of plasmolysed cells in a sample of 50 cells was counted under a microscope.

The results are shown in the table.

Concentration of sugar solution (mol/l)	Number of plasmolysed cells	
	Beetroot	Rhubarb
0.30	0	8
0.35	3	15
0.40	9	30
0.45	23	38
0.50	33	44
0.55	50	50

(a) Use the information in the table to

- (i) identify the concentration of sugar solution in which 30% of the rhubarb tissue cells are plasmolysed.

1

*Space for calculation*

\_\_\_\_\_ mol/l

- (ii) identify the concentration of sugar solution in the beetroot cells.

1

\_\_\_\_\_ mol/l



\* X 8 0 7 7 5 0 1 0 6 \*

2. (continued)

- (b) On the grid, complete the vertical axis and plot a line graph to show the effect of concentration of sugar solution on the number of plasmolysed rhubarb cells.

2

(An additional grid, if required, can be found on page 29.)

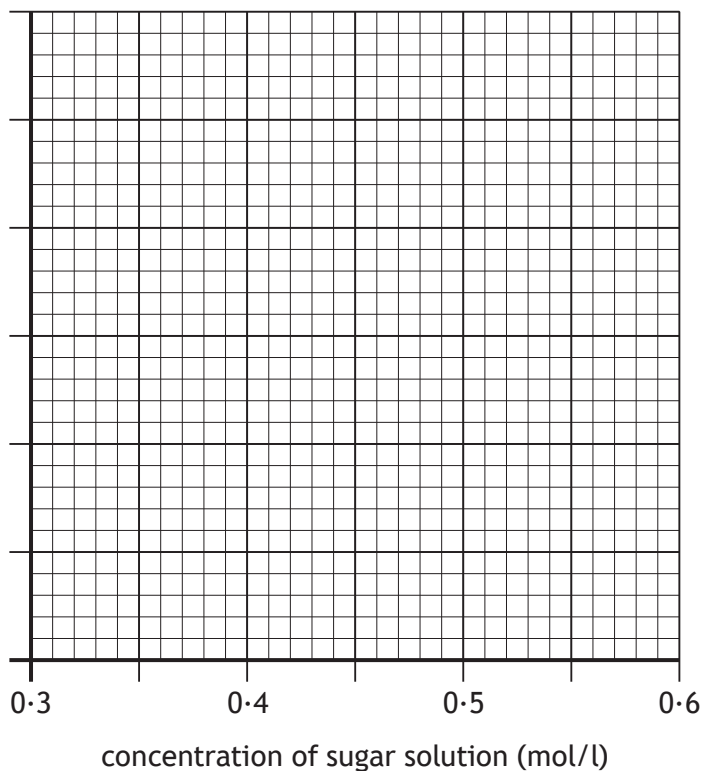

[Turn over



3. The diagram shows a section of a cell membrane.

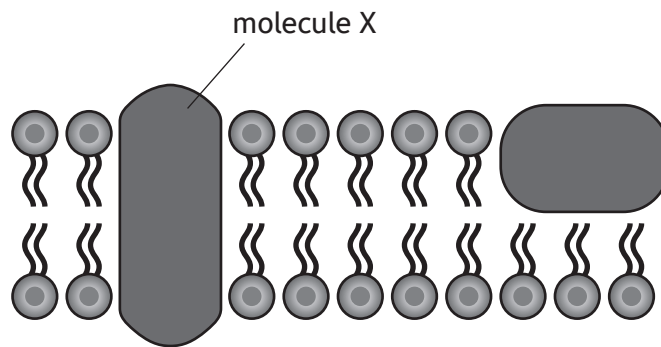

(a) Molecule X is involved in active transport.

Name this type of molecule.

1

\_\_\_\_\_

(b) Describe the differences in the processes of osmosis and active transport.

3

\_\_\_\_\_

\_\_\_\_\_

\_\_\_\_\_

\_\_\_\_\_

\_\_\_\_\_

\_\_\_\_\_

\_\_\_\_\_

\_\_\_\_\_

\_\_\_\_\_

\_\_\_\_\_



4. When a person cuts their finger, a blood clot forms at the wound. To form the clot, an enzyme converts a soluble protein into an insoluble protein.

(a) The soluble protein is the substrate for the enzyme.

Name the part of the enzyme that binds to its substrate.

1

\_\_\_\_\_

(b) The graph shows the time taken for the enzyme to clot samples of blood at different temperatures.

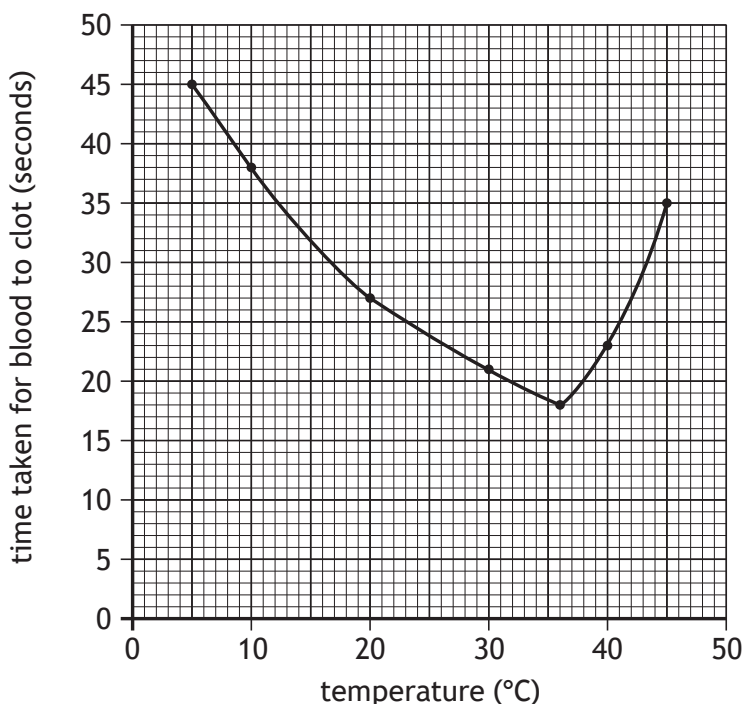

(i) Identify the optimum temperature for this enzyme.

1

\_\_\_\_\_°C

(ii) An enzyme can be completely denatured at very high temperatures, meaning that it can no longer catalyse its reaction.

Describe what has happened to the enzyme **and** explain why the reaction no longer occurs.

2

\_\_\_\_\_  
 \_\_\_\_\_  
 \_\_\_\_\_  
 \_\_\_\_\_



5. (a) The diagram represents two possible pathways when glucose is broken down in muscle cells.

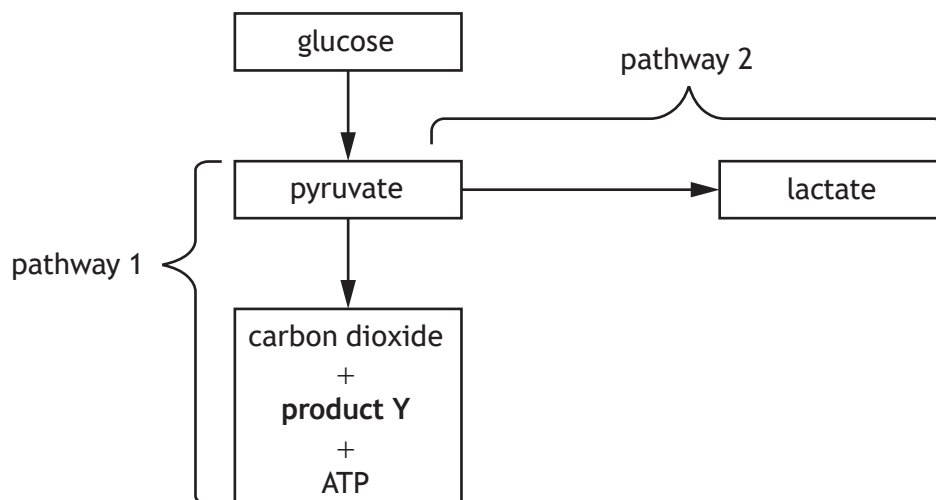

- (i) Name product Y. 1
- \_\_\_\_\_
- (ii) Pathway 2 only occurs in the absence of a particular substance.  
Name this substance. 1
- \_\_\_\_\_
- (iii) State the yield of ATP molecules when a glucose molecule is broken  
down to pyruvate. 1
- \_\_\_\_\_



5. (continued)

MARKS

DO NOT WRITE IN THIS MARGIN

- (b) Muscles decrease in length as they contract.

The diagram shows part of an investigation into the effect of ATP concentration on muscle contraction.

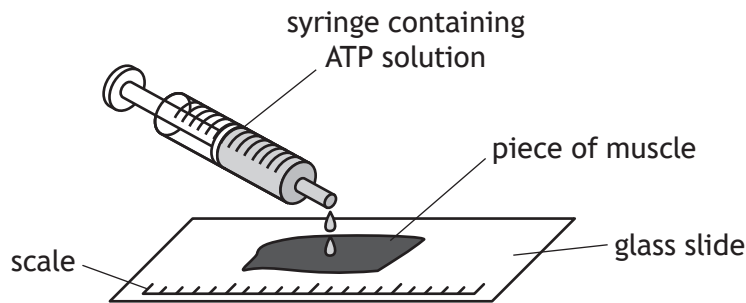

The table shows the results of the investigation.

ATP concentration (mg/100 ml)	Length of muscle (mm)			Percentage decrease in length
	At start	After 10 minutes	Decrease	
100	25	24.2	0.8	3.2
500	35	31.5	3.5	10
750	30	24.6	5.4	

- (i) Complete the table by calculating the percentage decrease in the length of the muscle when the ATP concentration was 750 mg/100 ml.

1

*Space for calculation*

- (ii) Explain why the percentage decrease in length was calculated.

1

---



---

- (iii) Describe the relationship between the ATP concentration and muscle contraction.

1

---



---



6. The diagram shows the time taken for the stages that occur when a cell divides and grows.

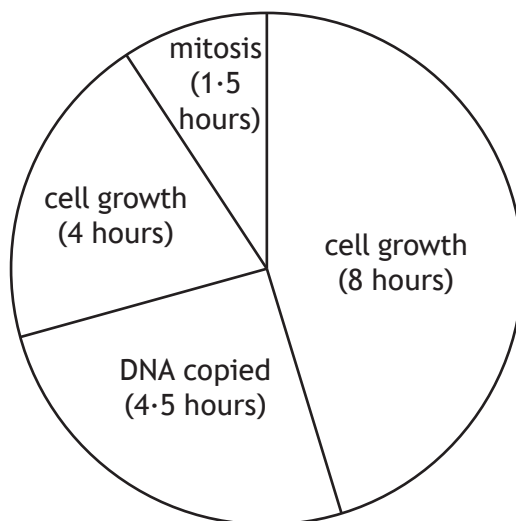

- (a) Calculate the simplest whole number ratio of the times taken for the stages shown in the diagram.

1

*Space for calculation*

\_\_\_\_\_ : \_\_\_\_\_ : \_\_\_\_\_  
mitosis                  DNA copied                  cell growth

- (b) Name the cell structure in which mitosis begins.

1

\_\_\_\_\_

- (c) Name the structure that pulls chromatids apart from each other during mitosis.

1

\_\_\_\_\_

- (d) Human cells produced by mitosis are diploid.

Explain what is meant by the term diploid.

1

\_\_\_\_\_  
\_\_\_\_\_





8. The flow chart shows the pathway of a reflex action involved in response to pain.

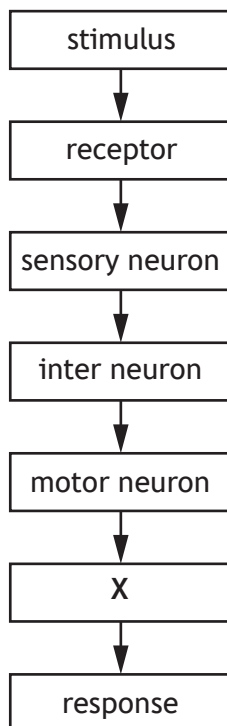

- (a) Identify structure X. 1

\_\_\_\_\_

- (b) Name the part of the body where the inter neuron of this reflex arc is found. 1

\_\_\_\_\_

- (c) Describe how messages travel along an inter neuron **and** are then transferred from the inter neuron to a motor neuron. 2

\_\_\_\_\_  
 \_\_\_\_\_  
 \_\_\_\_\_



9. (a) The compound phenylthiocarbamide (PTC) tastes very bitter to some people, while others are unable to taste it. The ability to taste PTC is an inherited characteristic controlled by the dominant allele.

T represents the tasting allele and t represents the non-tasting allele.

The family tree shows the pattern of inheritance for this characteristic.

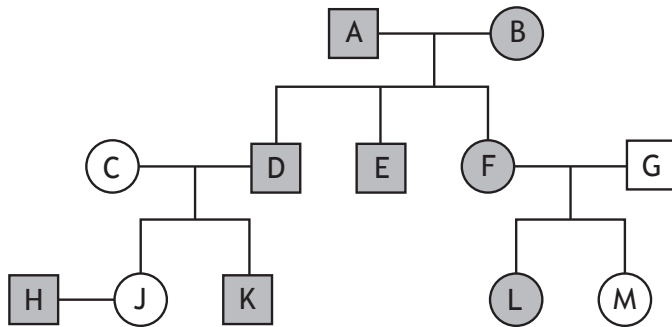

Key

Male	Female	Phenotype
		taster
		non-taster

- (i) Give the genotype of individual G.

1

\_\_\_\_\_

- (ii) Identify one heterozygous female.

1

Letter \_\_\_\_\_

- (iii) State how many individuals in this family tree are homozygous dominant.

1

\_\_\_\_\_

- (iv) Individuals H and J are having a child.

Predict the percentage chance of their child being able to taste PTC.

1

*Space for calculation*

\_\_\_\_\_ %

- (b) Characteristics controlled by more than one gene show continuous variation.

Explain the term continuous variation.

1

\_\_\_\_\_

\_\_\_\_\_



\* X 8 0 7 7 5 0 1 1 5 \*

10. (a) An investigation was carried out into the average rate of water loss from three species of plant, A, B and C at different air temperatures.

The graph shows the results.

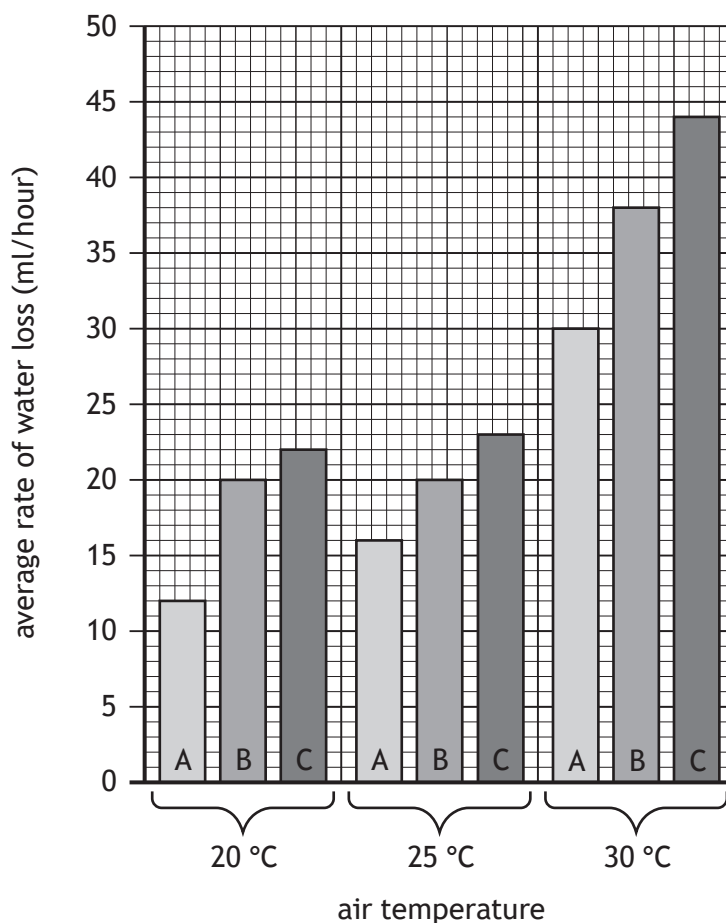

- (i) It was concluded that all three plant species showed an increase in the average rate of water loss as the air temperature increased.

Using data from the graph, explain why this was **not** a valid conclusion.

1

---



---

- (ii) Assuming all three plant species had the same rate of water intake, predict which species is most likely to survive during a long spell of hot, dry weather.

1

Species \_\_\_\_\_



10. (a) (continued)

(iii) An evaluation of the investigation was carried out.

Identify a factor that would need to have been controlled during the investigation to ensure the results were valid.

1

\_\_\_\_\_

(b) (i) Name the process by which water is transported through a plant and evaporates from its leaves.

1

\_\_\_\_\_

(ii) Name the structures in leaves from which water evaporates.

1

\_\_\_\_\_

[Turn over



\* X 8 0 7 7 5 0 1 1 7 \*

11. (a) The following diagram represents a human heart.

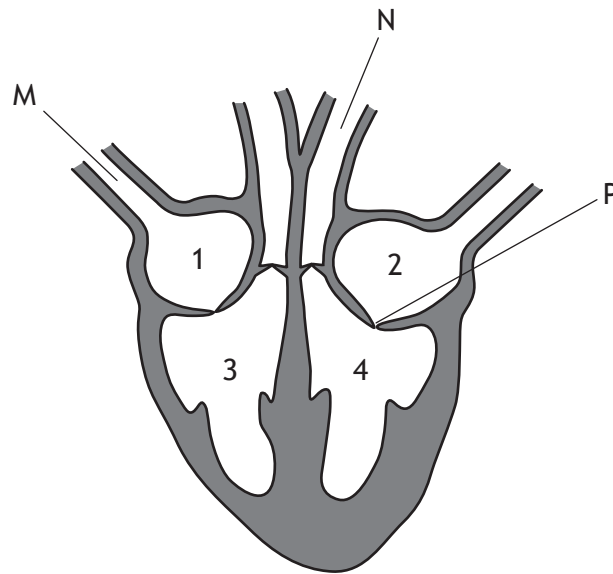

(i) Name blood vessel M.

1

\_\_\_\_\_

(ii) M and N are different types of blood vessels.

Identify a feature of blood vessel N that would **not** be found in vessel M.

1

\_\_\_\_\_

(iii) Explain why it is essential that there is a valve at position P.

2

\_\_\_\_\_

\_\_\_\_\_

\_\_\_\_\_



\* X 8 0 7 7 5 0 1 1 8 \*

11. (continued)

(b) Thicker muscle can push blood further. The average thickness of the outer wall of each chamber was measured as shown below.

1.5 mm      7.0 mm      15.0 mm      1.5 mm

Two students were asked to select the measurements most likely to correspond to each of the chambers. Their responses are shown in the table.

Chamber	Average thickness (mm)	
	Student A	Student B
1	1.5	1.5
2	1.5	1.5
3	15.0	7.0
4	7.0	15.0

Identify which student selected the correct measurements for each of the chambers.

Explain the reason for your choice.

1

Student \_\_\_\_\_

Explanation \_\_\_\_\_

\_\_\_\_\_

[Turn over



\* X 8 0 7 7 5 0 1 1 9 \*

12. The diagram represents a stage in the process of photosynthesis that requires light energy.

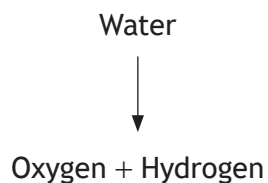

(a) (i) Name the organelles present in leaf cells where this stage takes place.

1

\_\_\_\_\_

(ii) Describe what happens to the oxygen and hydrogen produced during this stage.

2

Oxygen \_\_\_\_\_

Hydrogen \_\_\_\_\_



12. (continued)

(b) The graph shows the effect of three different factors on the rate of photosynthesis in a plant.

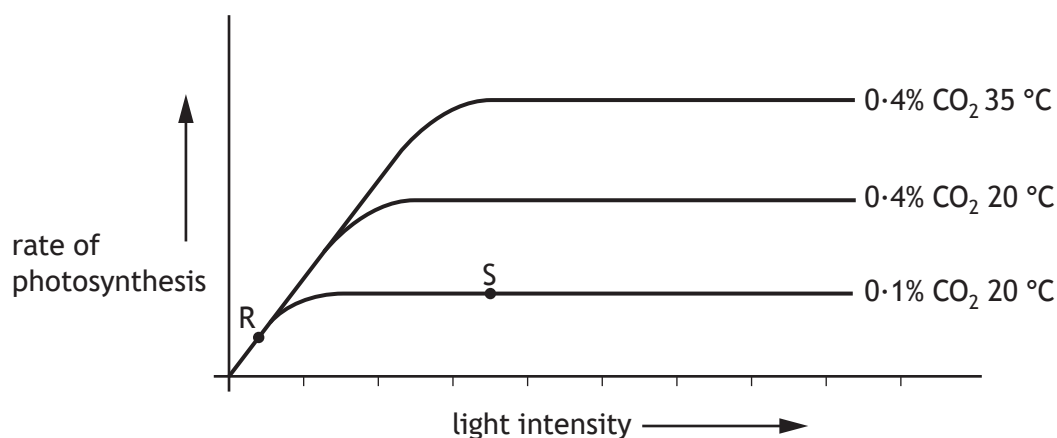

(i) Tick one box in each row of the table to indicate which factor is limiting photosynthesis at point R and point S.

2

Point	Limiting factor		
	Temperature	Light intensity	Carbon dioxide concentration
R			
S			

(ii) Explain why there is an increase in the rate of photosynthesis when there is an increase in the temperature from 20 °C to 35 °C.

2

---



---



---

[Turn over



### 13. Bees and pesticides

Research was carried out to determine the effect of different concentrations of pesticide on the feeding behaviour of bees.

A laboratory was separated into eight identical areas. Three feeding containers, with equal concentrations of sucrose solution, were placed in each area. Each solution was contaminated with a different concentration of pesticide, 0 parts per billion (ppb), 2 ppb, or 11 ppb.

The diagram shows how each area was set up.

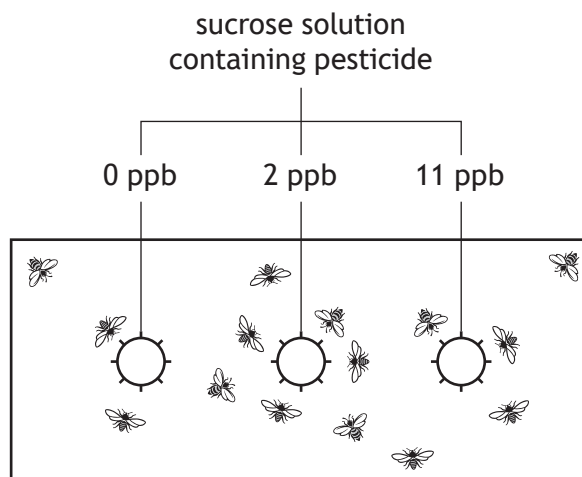

Every day bees were released and allowed to feed freely from any of the containers in their area for 6 hours. The volume of sucrose solution consumed from each container was measured daily over a period of 10 days.

Researchers expected to find that bees would feed less on sucrose solution with increasing concentrations of pesticide.

On day 1 the average volume of sucrose solution consumed that was contaminated with 11 ppb of pesticide was 7.5 ml. This was similar to the 7.6 ml of 0 ppb solution consumed, but much more than the 6.4 ml of the 2 ppb solution consumed.

On day 10 the bees consumed an average of 7.7 ml of 0 ppb solution, 10.7 ml of 2 ppb solution and 10.4 ml of 11 ppb solution.



13. (continued)

- (a) Complete the table by adding a column heading and the relevant data from the passage.

2

(An additional table, if required, can be found on page 29.)

	Average volume of sucrose solution consumed (ml)	
	Day 1	Day 10
0		
2		
11		

- (b) (i) State one variable, mentioned in the passage, which was controlled to ensure validity in this investigation.

1

\_\_\_\_\_

- (ii) Suggest another variable, not already mentioned, which should also have been controlled to ensure validity.

1

\_\_\_\_\_

- (c) Describe how the data from day 10 did not show the results that the researchers expected.

1

\_\_\_\_\_  
 \_\_\_\_\_  
 \_\_\_\_\_

- (d) Pesticides have been detected in the body tissues of bees.

State the term that describes the build-up of these substances in living organisms.

1

\_\_\_\_\_

[Turn over



\* X 8 0 7 7 5 0 1 2 3 \*

14. An investigation was carried out into the effect of increasing antibiotic concentration on the survival of bacteria. Two different strains of bacteria were used, an original strain and a mutated strain.

The percentage of bacteria of each strain surviving after two days is shown in the graph.

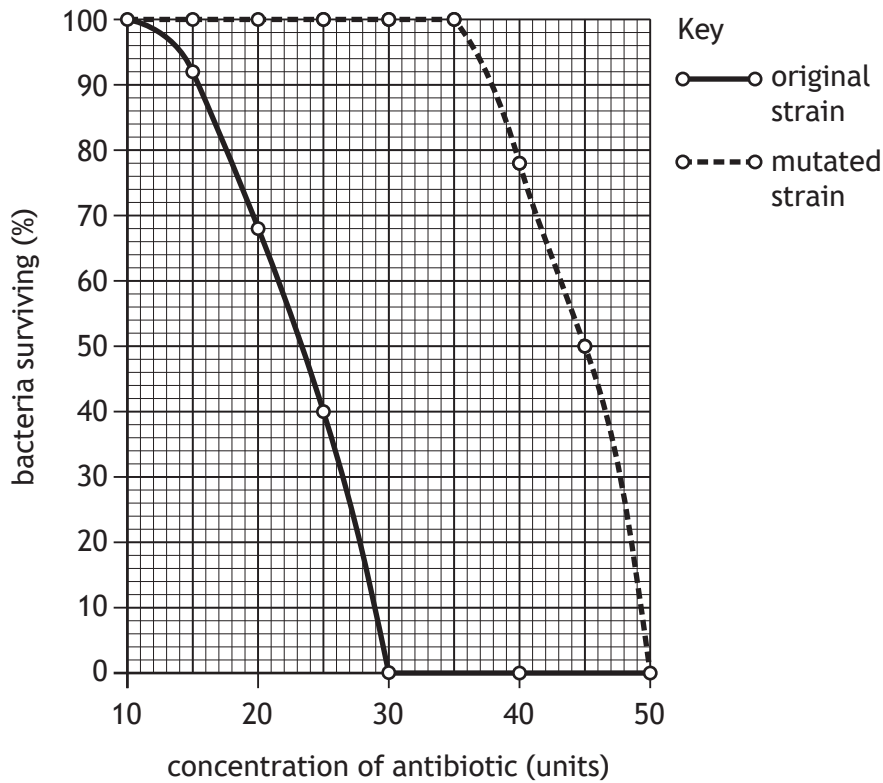

- (a) (i) Identify a concentration of antibiotic that has no effect on the survival of either strain of bacteria.

1

\_\_\_\_\_ units

- (ii) State the minimum concentration of antibiotic that would kill **all** of the bacteria.

1

\_\_\_\_\_ units

- (iii) Using the information given, describe the advantage the mutation gave the mutated strain over the original strain.

1

\_\_\_\_\_

\_\_\_\_\_



\* X 8 0 7 7 5 0 1 2 4 \*

MARKS

DO NOT  
WRITE IN  
THIS  
MARGIN

14. (continued)

- (b) The mutated strain of bacteria arose from the original as a result of mutation.

Give the definition of the term mutation.

1

---

---

- (c) State the term given to micro-organisms, such as bacteria, that cause disease.

1

---

[Turn over



\* X 8 0 7 7 5 0 1 2 5 \*

15. The Caledonian forest is an ecosystem in Scotland.

(a) Describe what is meant by the term ecosystem.

1

---



---

(b) Each organism found in the forest occupies a particular niche. Identify one biotic factor that helps determine an organism's niche.

1

---

(c) The area covered with Caledonian forest has decreased over time. In an attempt to reverse this decrease, some areas are being planted with one type of conifer tree, the Scots pine, or a variety of broad-leaved trees.

The table shows the number and types of tree planted in six areas between 2000 and 2010.

Area	Number of trees planted	Type of tree planted
1	6725	Scots pine
2	7900	broad-leaved
3	9430	Scots pine
4	11 845	broad-leaved
5	8475	Scots pine
6	9325	broad-leaved

For the areas planted with conifer trees, calculate the average number planted per area during this time.

1

*Space for calculation*

---



15. (continued)

(d) Pine martens are omnivores found in the Caledonian forest.



(i) Give the definition of the term omnivore.

1

---

(ii) Scottish wildcats compete with pine martens for resources.  
Name this type of competition.

1

---

[Turn over for next question



16. (a) Each food chain starts with a producer.

(i) State the meaning of the term producer.

1

---



---

(ii) Name the chemical in the cells of producers that traps light energy.

1

---

(b) Only 4.8% of light energy landing on a birchwood is absorbed by leaves. This is converted to chemical energy.

Calculate the total light energy landing on the leaves if they contain 27 000 units of chemical energy.

1

*Space for calculation*

\_\_\_\_\_ units

(c) The diagram shows a pyramid of energy for a typical food chain.



Explain why a pyramid of energy always has this shape.

1

---



---

[END OF QUESTION PAPER]

