

FOR OFFICIAL USE



--	--	--	--	--	--

National
Qualifications
2023

Mark

--

X857/76/01

**Physics
Paper 2**

WEDNESDAY, 17 MAY

10:15 AM – 12:30 PM



* X 8 5 7 7 6 0 1 *

Fill in these boxes and read what is printed below.

Full name of centre

--

Town

--

Forename(s)

--

Surname

--

Number of seat

--

Date of birth

Day

--	--

Month

--	--

Year

--	--

Scottish candidate number

--	--	--	--	--	--	--	--	--	--

Total marks — 130

Attempt ALL questions.

You may use a calculator.

Reference may be made to the Data Sheet on *page 02* of this booklet and to the relationship sheet X857/76/11.

Care should be taken to give an appropriate number of significant figures in the final answers to calculations.

Write your answers clearly in the spaces provided in this booklet. Additional space for answers and rough work is provided at the end of this booklet. If you use this space you must clearly identify the question number you are attempting. Any rough work must be written in this booklet. Score through your rough work when you have written your final copy.

Use **blue** or **black** ink.

Before leaving the examination room you must give this booklet to the Invigilator; if you do not, you may lose all the marks for this paper.



* X 8 5 7 7 6 0 1 0 1 *

DATA SHEET

COMMON PHYSICAL QUANTITIES

Quantity	Symbol	Value	Quantity	Symbol	Value
Speed of light in vacuum	c	$3.00 \times 10^8 \text{ m s}^{-1}$	Planck's constant	h	$6.63 \times 10^{-34} \text{ J s}$
Magnitude of the charge on an electron	e	$1.60 \times 10^{-19} \text{ C}$	Mass of electron	m_e	$9.11 \times 10^{-31} \text{ kg}$
Universal Constant of Gravitation	G	$6.67 \times 10^{-11} \text{ m}^3 \text{ kg}^{-1} \text{ s}^{-2}$	Mass of neutron	m_n	$1.675 \times 10^{-27} \text{ kg}$
Gravitational acceleration on Earth	g	9.8 m s^{-2}	Mass of proton	m_p	$1.673 \times 10^{-27} \text{ kg}$
Hubble's constant	H_0	$2.3 \times 10^{-18} \text{ s}^{-1}$			

REFRACTIVE INDICES

The refractive indices refer to sodium light of wavelength 589 nm and to substances at a temperature of 273 K.

Substance	Refractive index	Substance	Refractive index
Diamond	2.42	Water	1.33
Crown glass	1.50	Air	1.00

SPECTRAL LINES

Element	Wavelength (nm)	Colour	Element	Wavelength (nm)	Colour
Hydrogen	656	Red	Cadmium	644	Red
	486	Blue-green		509	Green
	434	Blue-violet		480	Blue
	410	Violet	Lasers		
	397	Ultraviolet	Element	Wavelength (nm)	Colour
	389	Ultraviolet	Carbon dioxide	9550 } 10590 }	Infrared
Sodium	589	Yellow	Helium-neon	633	Red

PROPERTIES OF SELECTED MATERIALS

Substance	Density (kg m^{-3})	Melting point (K)	Boiling point (K)
Aluminium	2.70×10^3	933	2623
Copper	8.96×10^3	1357	2853
Ice	9.20×10^2	273
Sea Water	1.02×10^3	264	377
Water	1.00×10^3	273	373
Air	1.29
Hydrogen	9.0×10^{-2}	14	20

The gas densities refer to a temperature of 273 K and a pressure of $1.01 \times 10^5 \text{ Pa}$.



* X 8 5 7 7 6 0 1 0 2 *

[Turn over for next question

DO NOT WRITE ON THIS PAGE



* X 8 5 7 7 6 0 1 0 3 *

Total marks — 130
 Attempt ALL questions

1. A van is travelling along a straight, level road at a constant speed of 13.4 m s^{-1} as it approaches a set of traffic lights. The driver sees the lights change to red and applies the brakes.

The van has a constant acceleration of -2.85 m s^{-2} before coming to rest at the traffic lights.

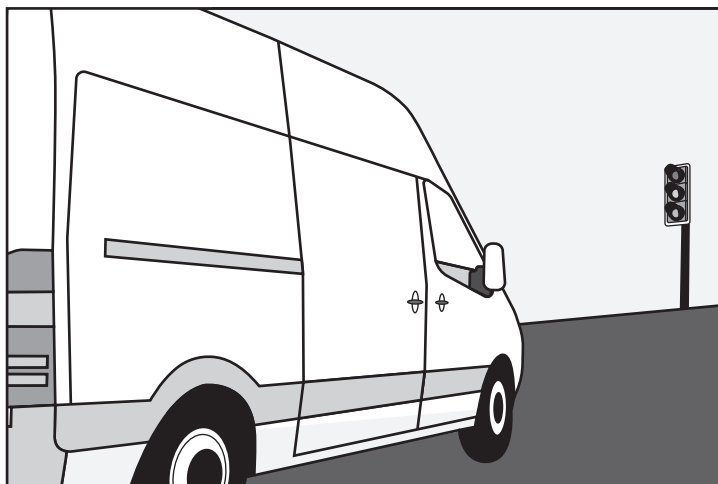

- (a) Calculate the distance travelled by the van during braking.

3

Space for working and answer



1. (continued)

(b) Calculate the time taken for the van to come to rest during braking.

3

Space for working and answer

(c) Complete the sketch graph of velocity against time for the van's motion during braking.

2

Numerical values are required on both axes.

(An additional graph, if required, can be found on *page 43*.)

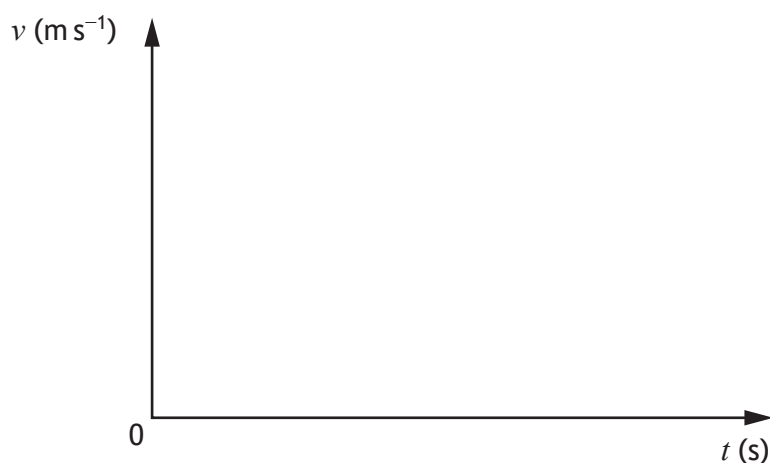

[Turn over



2. An adult with a child is cycling along a straight level path. The child is in a trailer, which is connected to the bike by a tow bar.



tow bar

The combined mass of the bike and the adult is 85 kg.

The combined mass of the child and trailer is 28 kg.

The forward force on the bike and trailer is 125 N.

A frictional force of 45 N acts on the bike.

A frictional force of 15 N acts on the trailer.

- (a) Show that the acceleration of the bike and trailer is 0.58 m s^{-2} .

2

Space for working and answer



2. (continued)

- (b) Determine the magnitude of the tension in the tow bar.

Space for working and answer

4

- (c) As the speed of the bike and trailer increases, the friction forces on both the bike and the trailer increase.

The acceleration of the bike and trailer remains 0.58 m s^{-2} .

State whether the tension in the tow bar increases, decreases, or stays the same.

Justify your answer.

2



* X 8 5 7 7 6 0 1 0 7 *

3. During a practice session for a Grand Prix, two Formula 1 cars collide in the pit lane.

Car X has a mass of 760 kg and is travelling at 12.0 m s^{-1} .

Car Y has a mass of 840 kg and is travelling at 4.0 m s^{-1} .

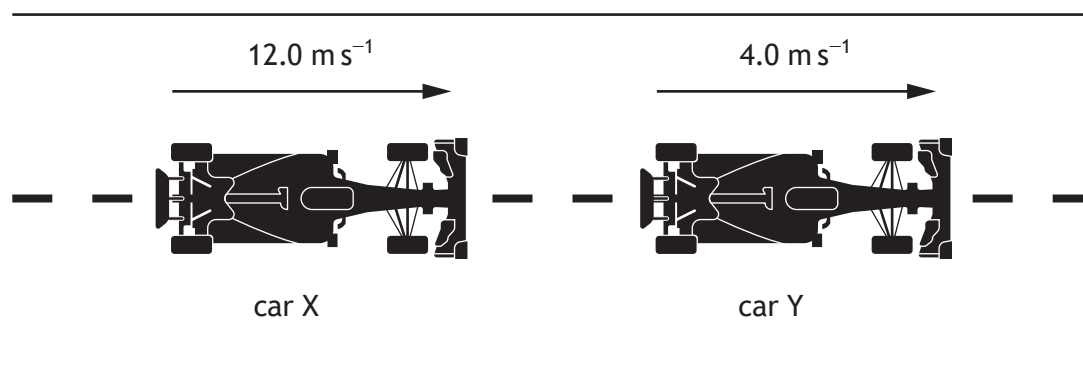

The cars collide and move off separately.

Car Y moves off with a velocity of 8.5 m s^{-1} .

- (a) Calculate the velocity of car X immediately after the collision.

Space for working and answer

3



* X 8 5 7 7 6 0 1 0 8 *

3. (continued)

(b) Show by calculation that the collision is inelastic.

Space for working and answer

4

(c) During the collision, the cars are in contact for 0.82 s.

Calculate the magnitude of the average force car X exerts on car Y.

Space for working and answer

3



* X 8 5 7 7 6 0 1 0 9 *

3. (continued)

- (d) One safety feature on Formula 1 racetracks is the use of tyre walls on bends. Tyre walls are designed to protect the driver in the event of their car leaving the track.

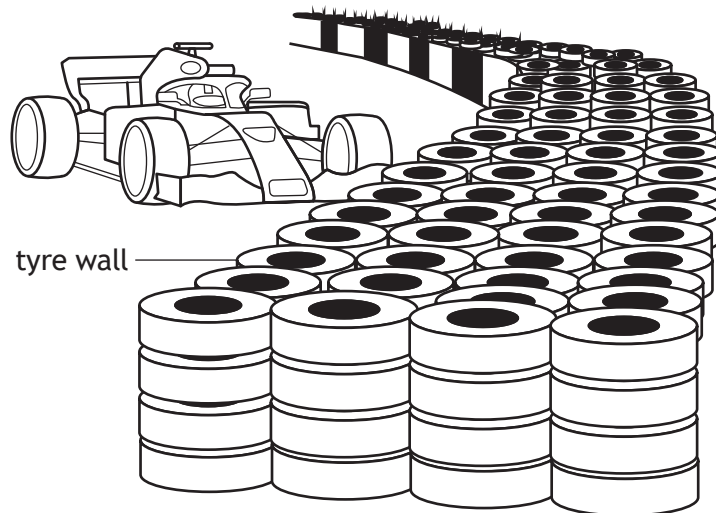

Explain how tyre walls protect the driver.

2



[Turn over for next question

DO NOT WRITE ON THIS PAGE



* X 8 5 7 7 6 0 1 1 1 *

4. Two trains depart from a station at the same time. The trains travel side by side in the same direction, along parallel tracks.

Train A is travelling at 3.5 m s^{-1} relative to the platform and train B is travelling at 4.0 m s^{-1} relative to the platform.



- (a) Determine the speed of train B relative to train A.

1

Space for working and answer

- (b) Once the trains are moving, a passenger on train A walks towards the rear of the train at a speed of 1.3 m s^{-1} .

Determine the speed of the passenger on train A relative to a passenger seated on train B.

1

Space for working and answer



* X 8 5 7 7 6 0 1 1 2 *

4. (continued)

- (c) Two physics students on train A are discussing the possibility of travelling at relativistic speeds. The students consider the train travelling at a speed of $0.9c$ relative to a stationary observer.

- (i) The train emits a beam of light towards the stationary observer.

State the speed of the emitted light as measured by the stationary observer.

Justify your answer.

2

- (ii) Train A has a length of 142 m, as measured in the frame of reference of the students on the train.

Calculate the length of train A when travelling at $0.9c$ as measured by the stationary observer.

Space for working and answer

3

[Turn over



* X 8 5 7 7 6 0 1 1 3 *

[BLANK PAGE]

DO NOT WRITE ON THIS PAGE



* X 8 5 7 7 6 0 1 1 4 *

5. A person is standing at the side of a road. A police car approaches and then passes the person at a constant speed of 31 m s^{-1} . A siren on the police car emits sound with a frequency of 440 Hz.



- (a) (i) Calculate the frequency of the sound heard by the person as the police car approaches.

The speed of sound in air is 340 m s^{-1} .

Space for working and answer

3

- (ii) State whether the frequency of the sound heard by the person as the police car moves away is greater than, the same as, or less than the frequency heard by the person as the police car approached.

You must justify your answer.

2

[Turn over



* X 8 5 7 7 6 0 1 1 5 *

5. (continued)

- (b) The emergency lights on top of the police car consist of an array of red LEDs and blue LEDs. A simplified diagram of the lighting circuit is shown.

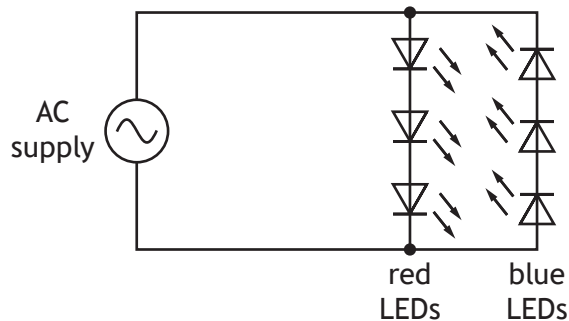

The red LEDs and blue LEDs each flash twice per second.

- (i) Determine the period of the AC supply used.

1

Space for working and answer

- (ii) Explain why the red LEDs and the blue LEDs do not light at the same time.

2



5. (b) (continued)

(iii) An energy band diagram for a red LED is shown.

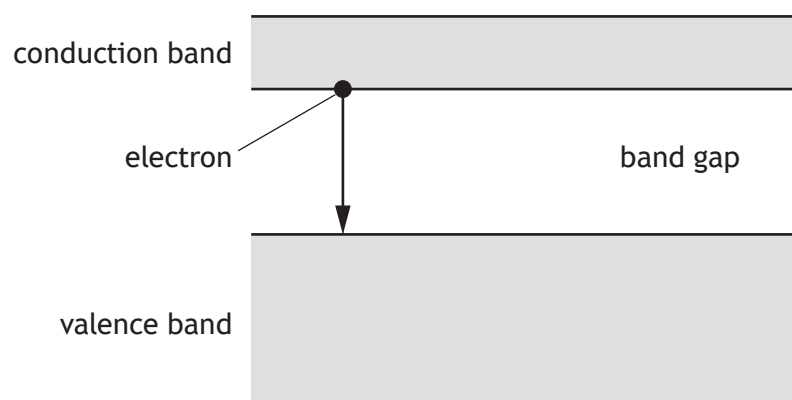

A photon of wavelength 625 nm is emitted when an electron falls from the conduction band to the valence band, across the energy band gap.

(A) Determine the energy of the emitted photon.

4

Space for working and answer

(B) Explain, in terms of the energy band gaps, the difference between photons emitted by the red LEDs and photons emitted by the blue LEDs.

2



6. The song History of Everything, used as the theme from the TV show The Big Bang Theory, contains the following lyrics.

*“Our whole universe was in a hot, dense state
Then nearly fourteen billion years ago expansion started, wait. . .
Since the dawn of man is really not that long
As every galaxy was formed in less time than it takes to sing this song
A fraction of a second and the elements were made. . .
It’s expanding ever outward but one day
It will cause the stars to go the other way. . .”*

(Written by Ed Robertson and Steven Page)

Using your knowledge of physics, comment on these lyrics.

3



* X 8 5 7 7 6 0 1 1 8 *

6. (continued)

[Turn over



* X 8 5 7 7 6 0 1 1 9 *

[BLANK PAGE]

DO NOT WRITE ON THIS PAGE



* X 8 5 7 7 6 0 1 2 0 *

7. Beta decay occurs when a neutron in an unstable nucleus decays into a proton and releases an electron and an antineutrino.

The following statement represents an example of beta decay.

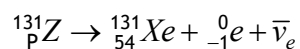

- (a) (i) (A) Determine the number represented by P. 1
Space for working and answer

- (B) Identify element Z. 1

- (ii) (A) In the Standard Model, state the type of fermion that includes electrons. 1

- (B) W-bosons and Z-bosons are the force-mediating particles associated with beta decay.

Name the fundamental force associated with beta decay. 1

[Turn over



7. (continued)

- (b) Positron Emission Tomography (PET) is a medical imaging technique, which uses isotopes that emit positrons.

Suitable isotopes are produced by bombarding a target with protons that have been accelerated in a cyclotron. A cyclotron consists of two D-shaped, hollow metal structures called 'dees', placed in a vacuum.

The diagram shows the cyclotron viewed from above.

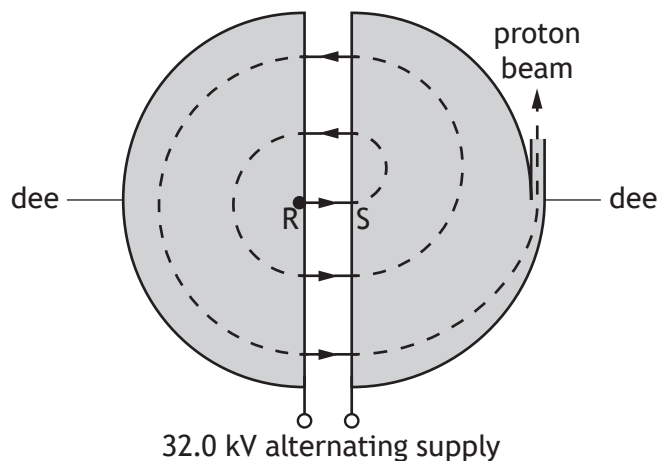

Protons are released from rest at R and are accelerated across the gap between the 'dees' by a voltage of 32.0 kV.

- (i) Determine the speed of a proton as it reaches S.

5

Space for working and answer



7. (b) (continued)

(ii) Explain why an alternating voltage is used in the cyclotron.

1

(c) A proton enters a region of magnetic field as shown.

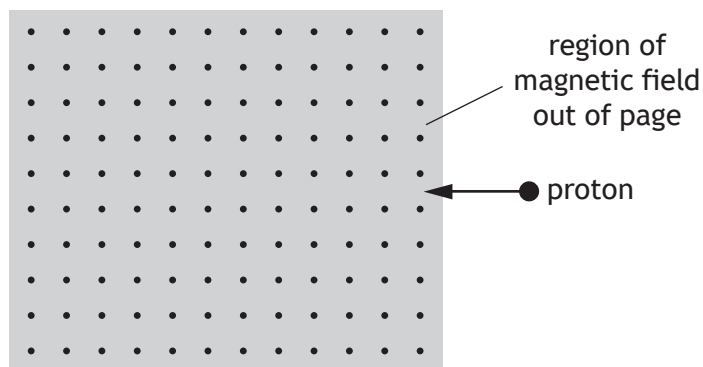

Determine the direction of the force exerted by the magnetic field on the proton immediately after entering the magnetic field.

1

[Turn over



8. A student carries out an experiment to verify the inverse square law for a point source of light.
- (a) Describe an experiment to verify the inverse square law for a point source of light.

2

- (b) The student records the following data from their experiment.

Distance d (m)	0.200	0.300	0.400	0.500	0.600
Irradiance I (W m^{-2})	142.0	63.1	35.5	22.7	15.8

- (i) State what is meant by the term *irradiance*.

1



8. (b) (continued)

- (ii) Use all the data to establish the relationship between irradiance I and distance d .

Space for working and answer

3

- (c) Explain why the irradiance decreases when the distance from a point source of light increases.

2

[Turn over



* X 8 5 7 7 6 0 1 2 5 *

9. The use of analogies from everyday life can help improve the understanding of physics concepts.

A group of students is discussing whether a vending machine can be used as an analogy for the photoelectric effect.

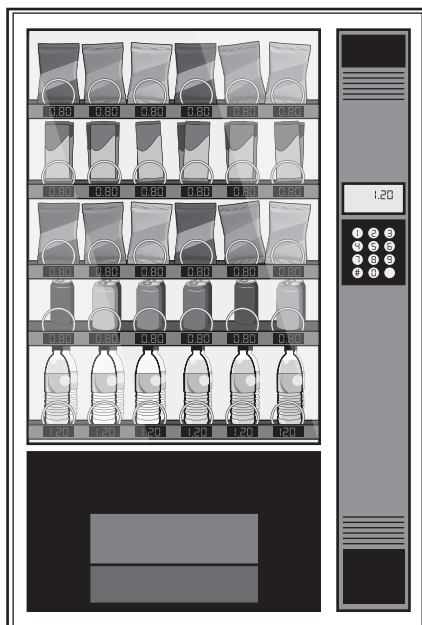

One student states “It’s like putting money into a vending machine. You won’t get your snack unless you have enough money, no matter how many coins you put in. If you put in too much money, your snack will come out of the vending machine and you will get change back.”

Using your knowledge of physics, comment on this analogy.

3



9. (continued)

[Turn over



* X 8 5 7 7 6 0 1 2 7 *

10. The Bohr model of the hydrogen atom can be represented by the diagram shown.

MARKS

DO NOT
WRITE IN
THIS
MARGIN

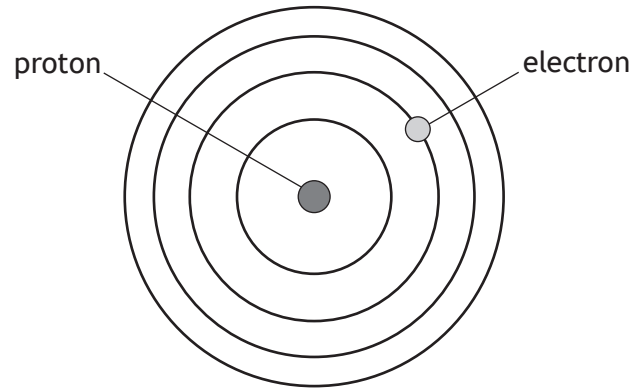

- (a) One of the features of the Bohr model of the hydrogen atom is that the electron can only occupy discrete energy levels.

State one other feature of the Bohr model of the hydrogen atom.

1

- (b) The line emission spectrum from a hydrogen discharge lamp has four lines in the visible region of the electromagnetic spectrum, as shown.



- (i) Explain how a line emission spectrum is produced.

2

- (ii) Explain why some of these lines appear brighter than others.

2



* X 8 5 7 7 6 0 1 2 8 *

10. (continued)

(c) Some of the energy levels of the hydrogen atom are shown.

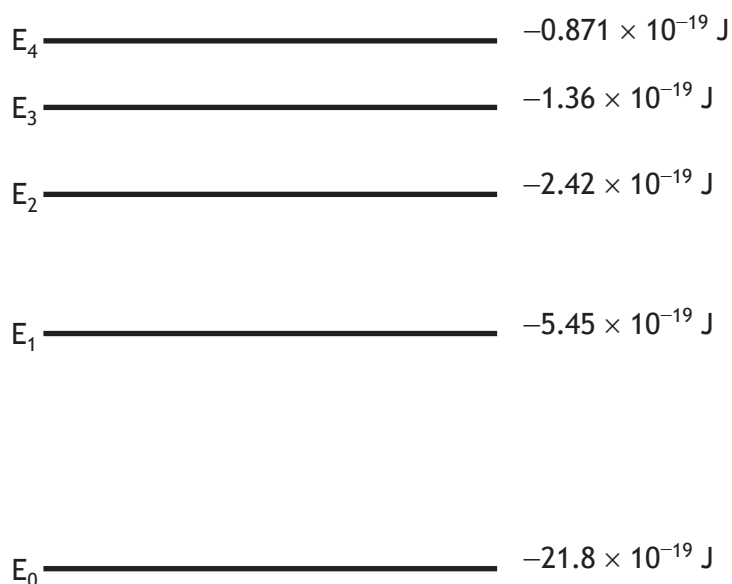

(i) State the number of possible emission lines caused by the transition of electrons between the energy levels shown.

1

(ii) (A) One of the emission lines produced is due to electron transitions from E_4 to E_1 .

Calculate the frequency of the photon emitted when an electron makes this transition.

3

Space for working and answer



10. (c) (ii) (continued)

(B) The photons produced by a different electron transition correspond to the blue-green spectral line in the hydrogen emission spectrum. State the wavelength of these photons.

1

(C) A distant galaxy has a recessional velocity of $4.52 \times 10^6 \text{ m s}^{-1}$. The hydrogen emission spectrum from the distant galaxy is viewed on Earth.

Determine the observed wavelength of the same spectral line as in (c) (ii) (B), when viewed on Earth.

5

Space for working and answer



MARKS DO NOT
WRITE IN
THIS
MARGIN

[Turn over for next question

DO NOT WRITE ON THIS PAGE



* X 8 5 7 7 6 0 1 3 1 *

11. A ray of blue light is incident on a triangular glass prism as shown.

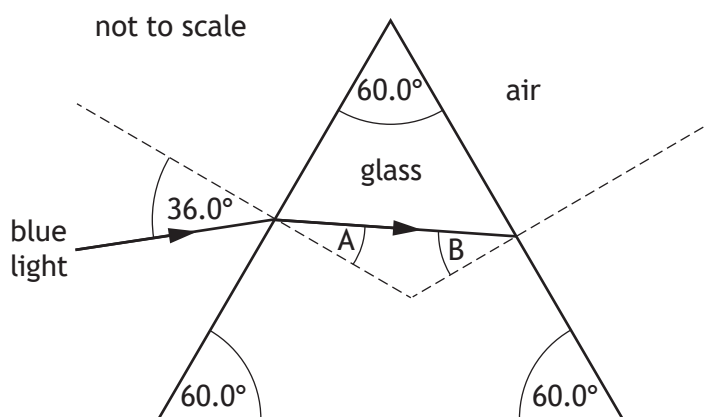

The refractive index of the glass for this blue light is 1.53.

(a) (i) Calculate angle A.

3

Space for working and answer

(ii) Determine angle B.

2

Space for working and answer



11. (continued)

(b) (i) State what is meant by the term *critical angle*.

1

(ii) Calculate the critical angle for this blue light in the glass prism.

3

Space for working and answer

(c) Complete the diagram below to show the path of the ray after it is incident on the glass-air boundary at the right-hand side of the prism.

Mark on the diagram the value of the angle between this ray and the normal after it is incident on this glass-air boundary.

3

(An additional diagram, if required, can be found on *page 43*.)

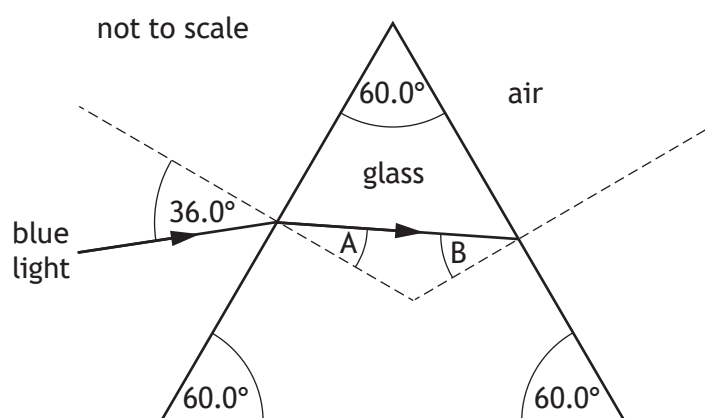

[Turn over



12. A battery has an EMF of 12 V and internal resistance r . The battery is connected in a circuit as shown.

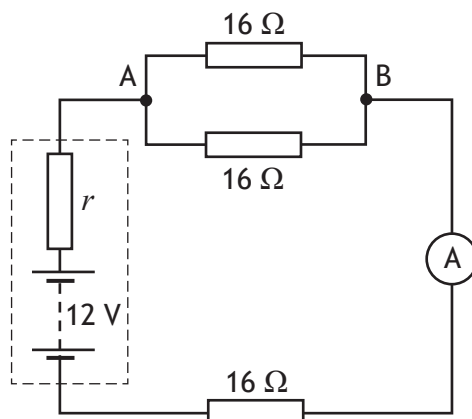

- (a) The reading on the ammeter is 0.38 A.
- (i) Determine the terminal potential difference (t.p.d.) of the battery. 5
Space for working and answer
- (ii) Calculate the internal resistance r of the battery. 3
Space for working and answer



12. (a) (continued)

(iii) Calculate the power dissipated by the internal resistance of the battery.

3

Space for working and answer

(b) The circuit is now rearranged as shown.

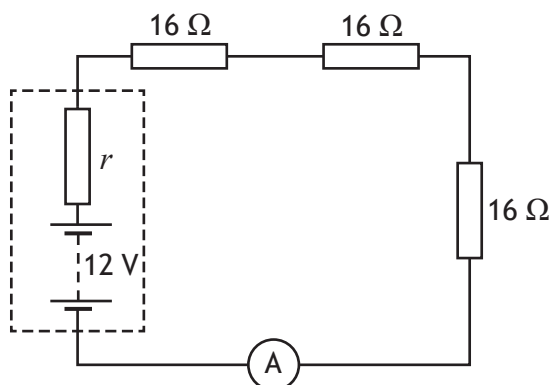

State whether the power dissipated by the internal resistance of the battery is greater than, equal to, or less than the value determined in (a) (iii).

You must justify your answer.

2

[Turn over



13. A student uses the circuit shown to determine the capacitance of a capacitor.

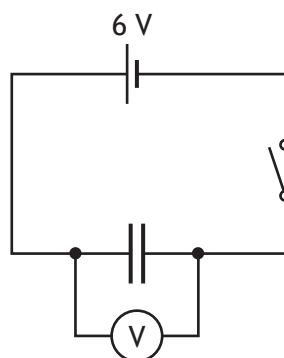

The capacitor is initially uncharged. The student closes the switch and the capacitor charges fully.

The student then measures the charge stored on the capacitor using a coulombmeter.

The student records the following measurements:

potential difference across the capacitor (5.7 ± 0.1) V;

charge stored on the capacitor (136.8 ± 0.1) mC.

(a) (i) Using these measurements, calculate the capacitance of the capacitor.

3

Space for working and answer



13. (a) (continued)

(ii) Determine the **absolute** uncertainty in the capacitance of the capacitor.

3

Space for working and answer

(b) The student discharges the capacitor and then connects it in the circuit shown.

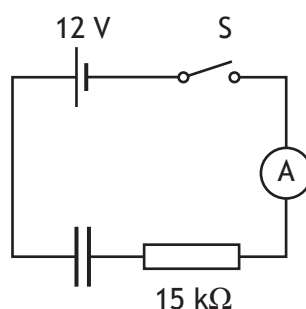

The student closes switch S and the capacitor charges.

The time t taken for the capacitor to charge fully can be estimated using the relationship

$$t = 5RC$$

where the symbols have their usual meaning.

Calculate the estimated time taken for the capacitor to charge fully.

2

Space for working and answer



14. A student carries out an experiment to determine the value of Planck's constant h , using various LEDs.

An LED that produces light of known frequency f is connected into the circuit as shown.

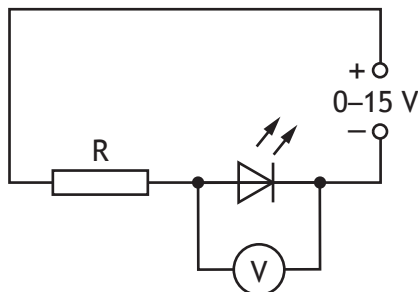

The student adjusts the voltage output of the variable power supply until they see the LED start to emit light.

The student records the potential difference across the LED at this point. This is the switch-on voltage V of the LED.

The student repeats this procedure using a number of LEDs, each producing light of a different known frequency.

To determine a value for Planck's constant, the student uses the relationship

$$eV = hf$$

where e is the charge on an electron.

The results obtained by the student are shown in the table.

$f (\times 10^{14} \text{ Hz})$	$V \text{ (V)}$
4.5	1.38
5.0	1.62
5.1	1.65
5.3	1.74
6.4	2.32

- (a) Using the square-ruled paper on *page 40*, draw a graph of V against f .
(The table of results is also shown on *page 41*, opposite the square-ruled paper).

3



14. (continued)

(b) Calculate the gradient of your graph.

Space for working and answer

2

(c) Using the gradient of your graph, determine a value for Planck's constant h .

Space for working and answer

2

(d) Suggest one improvement to the experiment the student could make that would improve the accuracy of their final result.

1

[END OF QUESTION PAPER]



* X 8 5 7 7 6 0 1 3 9 *

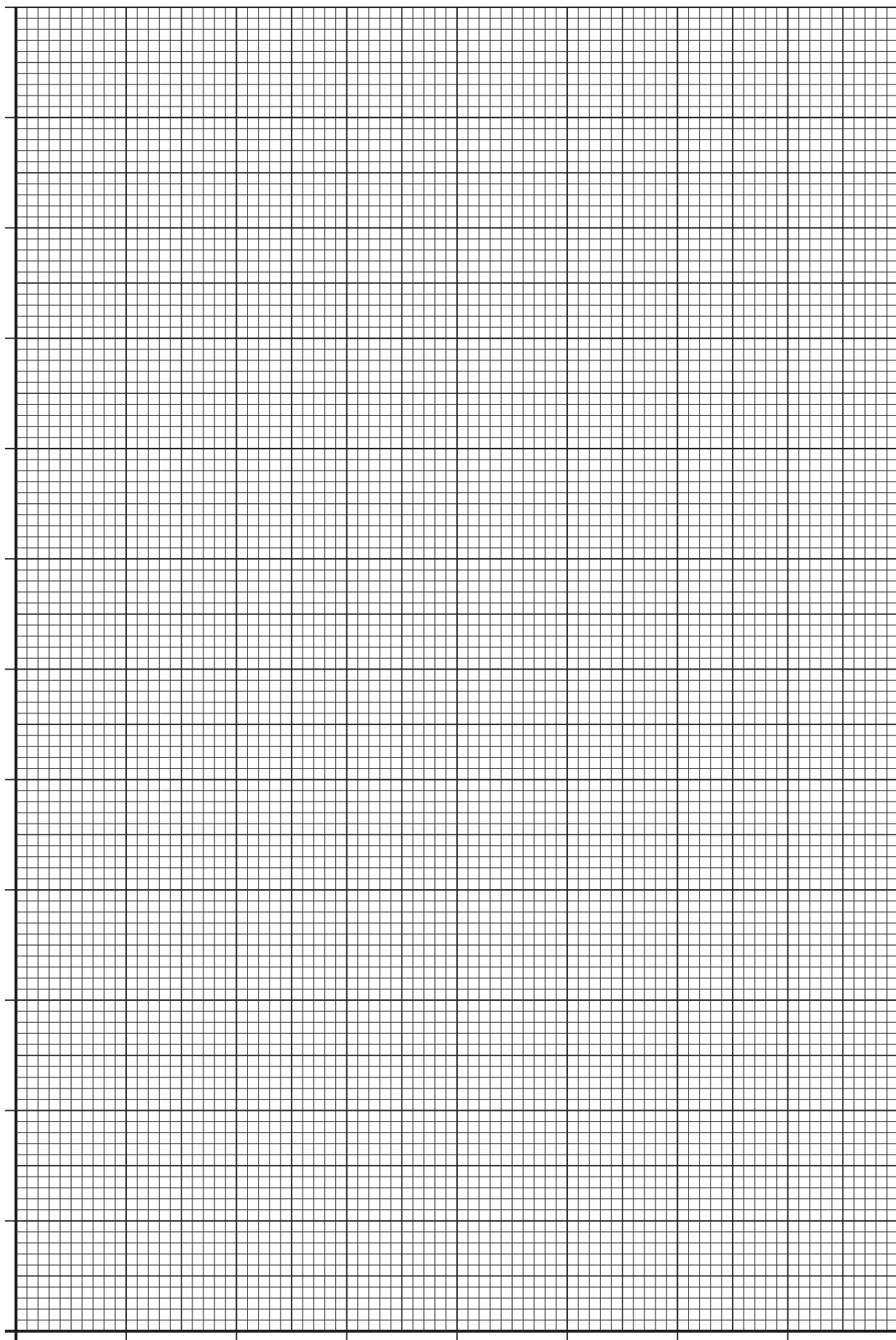

* X 8 5 7 7 6 0 1 4 0 *

ADDITIONAL SPACE FOR ANSWERS AND ROUGH WORK

Additional table for use with question 14 (a)

$f (\times 10^{14} \text{ Hz})$	$V (\text{V})$
4.5	1.38
5.0	1.62
5.1	1.65
5.3	1.74
6.4	2.32



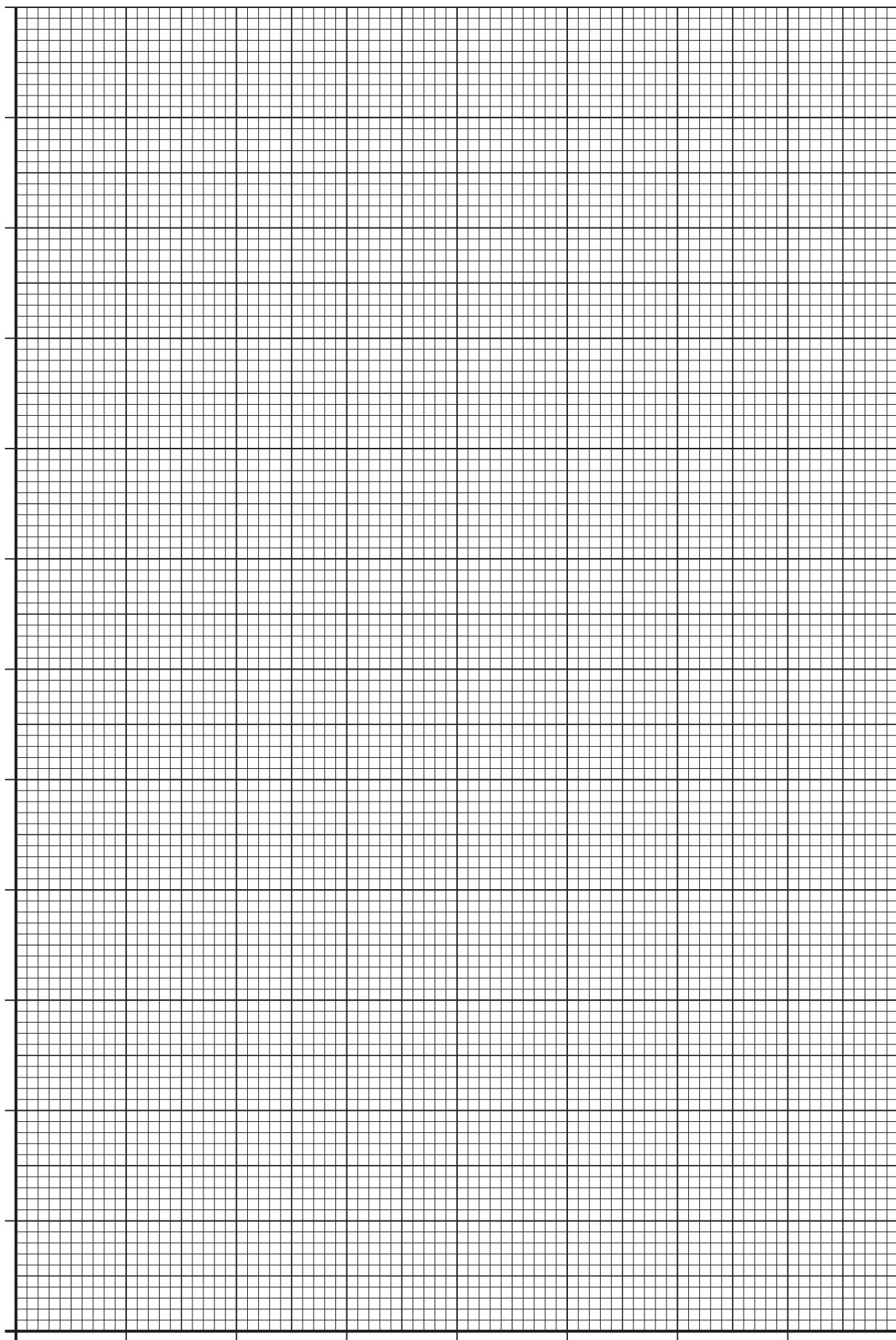

* X 8 5 7 7 6 0 1 4 2 *

ADDITIONAL SPACE FOR ANSWERS AND ROUGH WORK

Additional graph for use with question 1 (c)

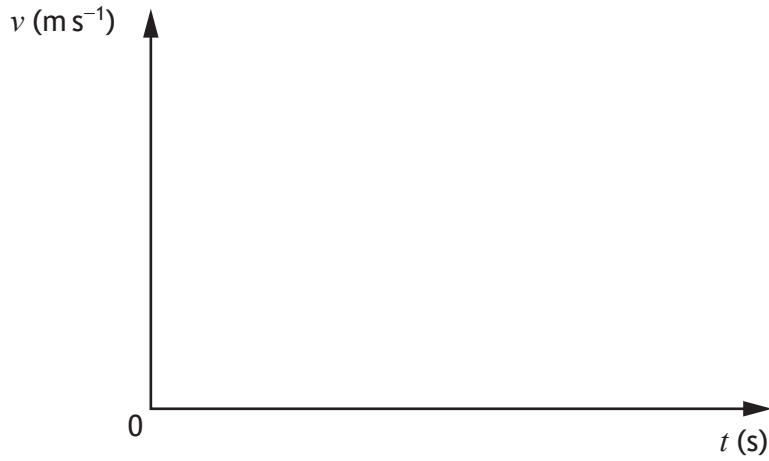

Additional diagram for use with question 11 (c)

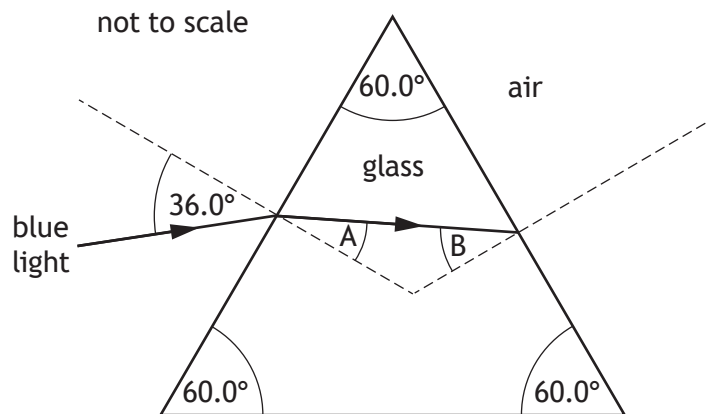

MARKS DO NOT
WRITE IN
THIS
MARGIN

ADDITIONAL SPACE FOR ANSWERS AND ROUGH WORK



* X 8 5 7 7 6 0 1 4 4 *

MARKS DO NOT
WRITE IN
THIS
MARGIN

ADDITIONAL SPACE FOR ANSWERS AND ROUGH WORK



* X 8 5 7 7 6 0 1 4 5 *

[BLANK PAGE]

DO NOT WRITE ON THIS PAGE



* X 8 5 7 7 6 0 1 4 6 *

[BLANK PAGE]

DO NOT WRITE ON THIS PAGE



* X 8 5 7 7 6 0 1 4 7 *

[BLANK PAGE]

DO NOT WRITE ON THIS PAGE

Acknowledgement of copyright

Question 2 Brocreative/shutterstock.com

Question 4 Iscotlanda Photography/shutterstock.com

Question 6 Lyrics are taken from 'The History of Everything' (Theme Song of *The Big Bang Theory*) by Ed Robertson and Steven Page.

SQA has made every effort to trace the owners of copyright of this item and seek permissions. We are happy to discuss permission requirements and incorporate any missing acknowledgement. Please contact question.papers@sqa.org.uk.



* X 8 5 7 7 6 0 1 4 8 *