



National
Qualifications
2017

X757/76/02

Physics
Section 1 — Questions

WEDNESDAY, 17 MAY

9:00 AM – 11:30 AM

Instructions for the completion of Section 1 are given on *Page 02* of your question and answer booklet X757/76/01.

Record your answers on the answer grid on *Page 03* of your question and answer booklet.

Reference may be made to the Data Sheet on *Page 02* of this booklet and to the Relationships Sheet X757/76/11.

Before leaving the examination room you must give your question and answer booklet to the Invigilator; if you do not, you may lose all the marks for this paper.



* X 7 5 7 7 6 0 2 *

DATA SHEET

COMMON PHYSICAL QUANTITIES

Quantity	Symbol	Value	Quantity	Symbol	Value
Speed of light in vacuum	c	$3.00 \times 10^8 \text{ m s}^{-1}$	Planck's constant	h	$6.63 \times 10^{-34} \text{ J s}$
Magnitude of the charge on an electron	e	$1.60 \times 10^{-19} \text{ C}$	Mass of electron	m_e	$9.11 \times 10^{-31} \text{ kg}$
Universal Constant of Gravitation	G	$6.67 \times 10^{-11} \text{ m}^3 \text{ kg}^{-1} \text{ s}^{-2}$	Mass of neutron	m_n	$1.675 \times 10^{-27} \text{ kg}$
Gravitational acceleration on Earth	g	9.8 m s^{-2}	Mass of proton	m_p	$1.673 \times 10^{-27} \text{ kg}$
Hubble's constant	H_0	$2.3 \times 10^{-18} \text{ s}^{-1}$			

REFRACTIVE INDICES

The refractive indices refer to sodium light of wavelength 589 nm and to substances at a temperature of 273 K.

Substance	Refractive index	Substance	Refractive index
Diamond	2.42	Water	1.33
Crown glass	1.50	Air	1.00

SPECTRAL LINES

Element	Wavelength/nm	Colour	Element	Wavelength/nm	Colour
Hydrogen	656	Red	Cadmium	644	Red
	486	Blue-green		509	Green
	434	Blue-violet		480	Blue
	410	Violet	Lasers		
	397	Ultraviolet	<i>Element</i>	<i>Wavelength/nm</i>	<i>Colour</i>
	389	Ultraviolet	Carbon dioxide	9550 } 10590 }	Infrared
Sodium	589	Yellow	Helium-neon	633	Red

PROPERTIES OF SELECTED MATERIALS

Substance	Density/kg m ⁻³	Melting Point/K	Boiling Point/K
Aluminium	2.70×10^3	933	2623
Copper	8.96×10^3	1357	2853
Ice	9.20×10^2	273
Sea Water	1.02×10^3	264	377
Water	1.00×10^3	273	373
Air	1.29
Hydrogen	9.0×10^{-2}	14	20

The gas densities refer to a temperature of 273 K and a pressure of $1.01 \times 10^5 \text{ Pa}$.

SECTION 1 — 20 marks

Attempt ALL questions

1. The graph shows how the velocity of an object varies with time.

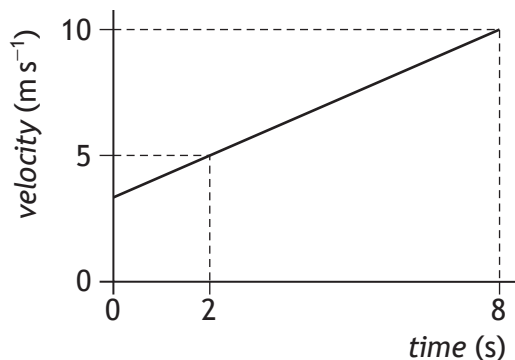

The acceleration of the object is

- A 0.83 m s⁻²
 - B 1.2 m s⁻²
 - C 2.5 m s⁻²
 - D 5.0 m s⁻²
 - E 6.0 m s⁻².
2. A block is resting on a horizontal surface.
A force of 24 N is now applied as shown and the block slides along the surface.

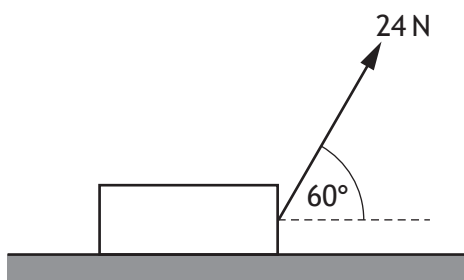

The mass of the block is 20 kg.

The acceleration of the block is 0.20 m s⁻².

The force of friction acting on the block is

- A 4.0 N
- B 8.0 N
- C 12 N
- D 16 N
- E 25 N.

3. The graph shows how the vertical speed of a skydiver varies with time.

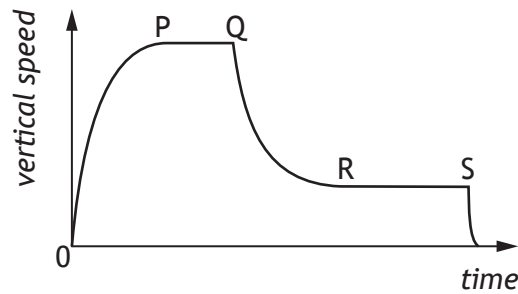

A student uses information from the graph to make the following statements.

- I The acceleration of the skydiver is greatest between P and Q.
- II The air resistance acting on the skydiver between Q and R is less than the weight of the skydiver.
- III The forces acting on the skydiver are balanced between R and S.

Which of these statements is/are correct?

- A I only
 - B II only
 - C III only
 - D I and II only
 - E I, II and III
4. A spacecraft is travelling at a constant speed of $2.75 \times 10^8 \text{ m s}^{-1}$ relative to a planet. A technician on the spacecraft measures the length of the spacecraft as 125 m. An observer on the planet measures the length of the spacecraft as
- A 36 m
 - B 50 m
 - C 124 m
 - D 314 m
 - E 433 m.

5. A galaxy has a recessional velocity of $0.30c$.
Hubble's Law predicts that the distance between Earth and this galaxy is
- A 1.3×10^{17} m
 - B 3.9×10^{25} m
 - C 1.3×10^{26} m
 - D 1.4×10^{41} m
 - E 4.5×10^{42} m.
6. Measurements of the expansion rate of the Universe lead to the conclusion that the rate of expansion is increasing.
Present theory proposes that this is due to
- A redshift
 - B dark matter
 - C dark energy
 - D the gravitational force
 - E cosmic microwave background radiation.
7. A student makes the following statements about the radiation emitted by stellar objects.
- I Stellar objects emit radiation over a wide range of frequencies.
 - II The peak wavelength of radiation is longer for hotter objects than for cooler objects.
 - III At all frequencies, hotter objects emit more radiation per unit surface area per unit time than cooler objects.
- Which of these statements is/are correct?
- A I only
 - B III only
 - C I and II only
 - D I and III only
 - E I, II and III

[Turn over

8. The following statement represents a nuclear reaction.

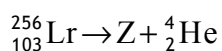

Nucleus Z is

- A ${}_{101}^{252}\text{Md}$
- B ${}_{101}^{252}\text{No}$
- C ${}_{101}^{256}\text{Md}$
- D ${}_{105}^{260}\text{Db}$
- E ${}_{103}^{252}\text{Lr}$.
9. Radiation is incident on a clean zinc plate causing photoelectrons to be emitted. The source of radiation is replaced with one emitting radiation of a higher frequency. The irradiance of the radiation incident on the plate remains unchanged. Which row in the table shows the effect of this change on the maximum kinetic energy of a photoelectron and the number of photoelectrons emitted per second?

	<i>Maximum kinetic energy of a photoelectron</i>	<i>Number of photoelectrons emitted per second</i>
A	no change	no change
B	no change	increases
C	increases	no change
D	increases	decreases
E	decreases	increases

10. Ultraviolet radiation of frequency 7.70×10^{14} Hz is incident on the surface of a metal. Photoelectrons are emitted from the surface of the metal.

The maximum kinetic energy of an emitted photoelectron is 2.67×10^{-19} J.

The work function of the metal is

- A 1.07×10^{-19} J
- B 2.44×10^{-19} J
- C 2.67×10^{-19} J
- D 5.11×10^{-19} J
- E 7.78×10^{-19} J.

11. A student makes the following statements about waves from coherent sources.

- I Waves from coherent sources have the same velocity.
- II Waves from coherent sources have the same wavelength.
- III Waves from coherent sources have a constant phase relationship.

Which of these statements is/are correct?

- A I only
- B II only
- C I and II only
- D I and III only
- E I, II and III

[Turn over

12. A ray of red light passes from a liquid to a transparent solid. The solid and the liquid have the same refractive index for this light. Which row in the table shows what happens to the speed and wavelength of the light as it passes from the liquid into the solid?

	<i>Speed</i>	<i>Wavelength</i>
A	decreases	decreases
B	decreases	increases
C	no change	increases
D	increases	no change
E	no change	no change

13. A ray of blue light passes from air into a transparent block as shown.

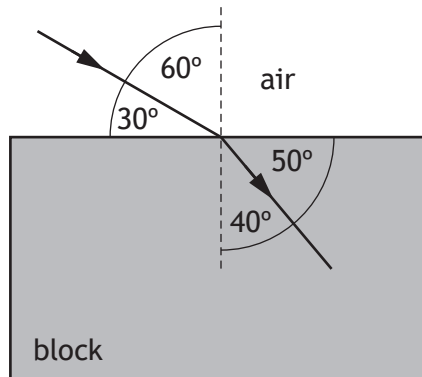

The speed of this light in the block is

- A $1.80 \times 10^8 \text{ m s}^{-1}$
- B $1.96 \times 10^8 \text{ m s}^{-1}$
- C $2.00 \times 10^8 \text{ m s}^{-1}$
- D $2.23 \times 10^8 \text{ m s}^{-1}$
- E $2.65 \times 10^8 \text{ m s}^{-1}$.

14. A student carries out an experiment to investigate how irradiance varies with distance.

A small lamp is placed at a distance d away from a light meter. The irradiance I at this distance is displayed on the meter. This measurement is repeated for a range of different distances.

The student uses these results to produce the graph shown.

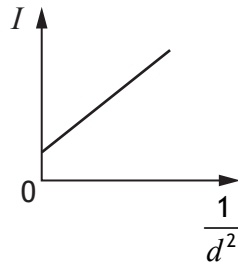

The graph indicates that there is a systematic uncertainty in this experiment.

Which of the following would be most likely to reduce the systematic uncertainty in this experiment?

- A Repeating the readings and calculating mean values.
 - B Replacing the small lamp with a larger lamp.
 - C Decreasing the brightness of the lamp.
 - D Repeating the experiment in a darkened room.
 - E Increasing the range of distances.
15. A point source of light is 8.00 m away from a surface. The irradiance, due to the point source, at the surface is 50.0 mW m^{-2} . The point source is now moved to a distance of 12.0 m from the surface.

The irradiance, due to the point source, at the surface is now

- A 22.2 mW m^{-2}
- B 26.0 mW m^{-2}
- C 33.3 mW m^{-2}
- D 75.0 mW m^{-2}
- E 267 mW m^{-2} .

[Turn over

16. The output from an a.c. power supply is connected to an oscilloscope. The trace seen on the oscilloscope screen is shown.

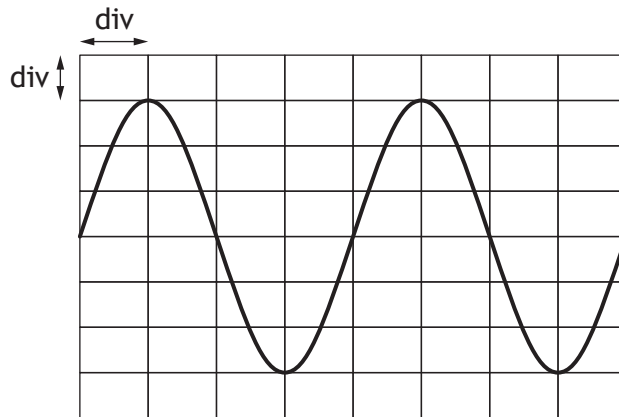

The Y-gain setting on the oscilloscope is 1.0 V/div .

The r.m.s. voltage of the power supply is

- A 2.1 V
 - B 3.0 V
 - C 4.0 V
 - D 4.2 V
 - E 6.0 V .
17. A $20\ \mu\text{F}$ capacitor is connected to a 12 V d.c. supply.
The maximum charge stored on the capacitor is
- A $1.4 \times 10^{-3}\text{ C}$
 - B $2.4 \times 10^{-4}\text{ C}$
 - C $1.4 \times 10^{-4}\text{ C}$
 - D $1.7 \times 10^{-6}\text{ C}$
 - E $6.0 \times 10^{-7}\text{ C}$.

18. A circuit containing a capacitor is set up as shown.

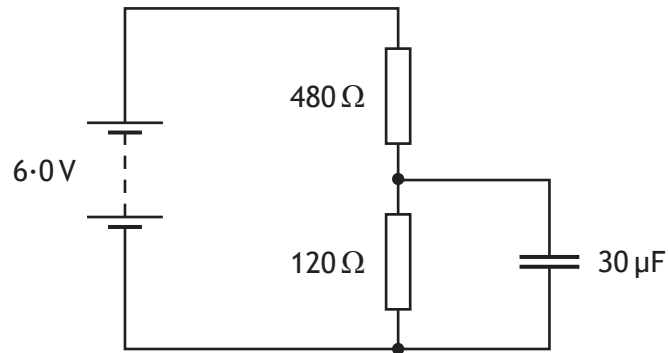

The supply has negligible internal resistance.

The maximum energy stored in the capacitor is

- A 5.4×10^{-4} J
 - B 3.5×10^{-4} J
 - C 1.4×10^{-4} J
 - D 3.4×10^{-5} J
 - E 2.2×10^{-5} J.
19. A student makes the following statements about conductors, insulators and semiconductors.
- I In conductors, the conduction band is completely filled with electrons.
 - II In insulators, the gap between the valence band and the conduction band is large.
 - III In semiconductors, increasing the temperature increases the conductivity.
- Which of these statements is/are correct?
- A I only
 - B II only
 - C III only
 - D I and II only
 - E II and III only

[Turn over for next question

20. Astronomers use the following relationship to determine the distance, d , to a star.

$$F = \frac{L}{4\pi d^2}$$

For a particular star the following measurements are recorded:

apparent brightness, $F = 4.4 \times 10^{-10} \text{ W m}^{-2}$

luminosity, $L = 6.1 \times 10^{30} \text{ W}$

Based on this information, the distance to this star is

- A $3.3 \times 10^{19} \text{ m}$
- B $1.5 \times 10^{21} \text{ m}$
- C $3.7 \times 10^{36} \text{ m}$
- D $1.1 \times 10^{39} \text{ m}$
- E $3.9 \times 10^{39} \text{ m}$.

[END OF SECTION 1. NOW ATTEMPT THE QUESTIONS IN SECTION 2 OF YOUR QUESTION AND ANSWER BOOKLET]