

X100/301

NATIONAL
QUALIFICATIONS
2011

WEDNESDAY, 18 MAY
9.00 AM – 10.30 AM

MATHEMATICS
HIGHER
Paper 1
(Non-calculator)

Read carefully

Calculators may NOT be used in this paper.

Section A – Questions 1–20 (40 marks)

Instructions for completion of **Section A** are given on page two.

For this section of the examination you must use an **HB pencil**.

Section B (30 marks)

- 1 Full credit will be given only where the solution contains appropriate working.
- 2 Answers obtained by readings from scale drawings will not receive any credit.



Read carefully

- 1 Check that the answer sheet provided is for **Mathematics Higher (Section A)**.
- 2 For this section of the examination you must use an **HB pencil** and, where necessary, an eraser.
- 3 Check that the answer sheet you have been given has **your name, date of birth, SCN** (Scottish Candidate Number) and **Centre Name** printed on it.
Do not change any of these details.
- 4 If any of this information is wrong, tell the Invigilator immediately.
- 5 If this information is correct, **print** your name and seat number in the boxes provided.
- 6 The answer to each question is **either** A, B, C or D. Decide what your answer is, then, using your pencil, put a horizontal line in the space provided (see sample question below).
- 7 There is **only one correct** answer to each question.
- 8 Rough working should **not** be done on your answer sheet.
- 9 At the end of the exam, put the **answer sheet for Section A inside the front cover of your answer book**.

Sample Question

A curve has equation $y = x^3 - 4x$.

What is the gradient at the point where $x = 2$?

- A 8
- B 1
- C 0
- D -4

The correct answer is **A—8**. The answer **A** has been clearly marked in **pencil** with a horizontal line (see below).

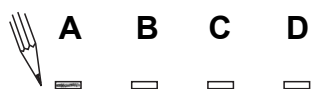

Changing an answer

If you decide to change your answer, carefully erase your first answer and, using your pencil, fill in the answer you want. The answer below has been changed to **D**.

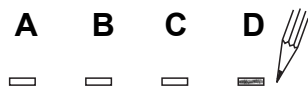

FORMULAE LIST

Circle:

The equation $x^2 + y^2 + 2gx + 2fy + c = 0$ represents a circle centre $(-g, -f)$ and radius $\sqrt{g^2 + f^2 - c}$.

The equation $(x - a)^2 + (y - b)^2 = r^2$ represents a circle centre (a, b) and radius r .

Scalar Product: $\mathbf{a} \cdot \mathbf{b} = |\mathbf{a}| |\mathbf{b}| \cos \theta$, where θ is the angle between \mathbf{a} and \mathbf{b}

or $\mathbf{a} \cdot \mathbf{b} = a_1 b_1 + a_2 b_2 + a_3 b_3$ where $\mathbf{a} = \begin{pmatrix} a_1 \\ a_2 \\ a_3 \end{pmatrix}$ and $\mathbf{b} = \begin{pmatrix} b_1 \\ b_2 \\ b_3 \end{pmatrix}$.

Trigonometric formulae: $\sin(A \pm B) = \sin A \cos B \pm \cos A \sin B$

$$\cos(A \pm B) = \cos A \cos B \mp \sin A \sin B$$

$$\sin 2A = 2 \sin A \cos A$$

$$\cos 2A = \cos^2 A - \sin^2 A$$

$$= 2 \cos^2 A - 1$$

$$= 1 - 2 \sin^2 A$$

Table of standard derivatives:

$f(x)$	$f'(x)$
$\sin ax$	$a \cos ax$
$\cos ax$	$-a \sin ax$

Table of standard integrals:

$f(x)$	$\int f(x) dx$
$\sin ax$	$-\frac{1}{a} \cos ax + C$
$\cos ax$	$\frac{1}{a} \sin ax + C$

[Turn over

SECTION A

ALL questions should be attempted.

1. Given that $\mathbf{p} = \begin{pmatrix} 2 \\ 5 \\ -7 \end{pmatrix}$, $\mathbf{q} = \begin{pmatrix} 1 \\ 0 \\ -1 \end{pmatrix}$ and $\mathbf{r} = \begin{pmatrix} -4 \\ 2 \\ 0 \end{pmatrix}$, express $2\mathbf{p} - \mathbf{q} - \frac{1}{2}\mathbf{r}$ in component form.

A $\begin{pmatrix} 1 \\ 9 \\ -15 \end{pmatrix}$

B $\begin{pmatrix} 1 \\ 11 \\ -13 \end{pmatrix}$

C $\begin{pmatrix} 5 \\ 9 \\ -13 \end{pmatrix}$

D $\begin{pmatrix} 5 \\ 11 \\ -15 \end{pmatrix}$

2. A line l has equation $3y + 2x = 6$.

What is the gradient of any line parallel to l ?

A -2

B $-\frac{2}{3}$

C $\frac{3}{2}$

D 2

3. The diagram shows the graph of $y = f(x)$.

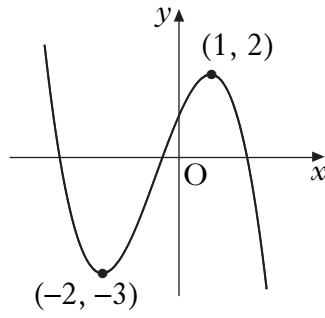

Which of the following shows the graph of $y = f(x + 2) - 1$?

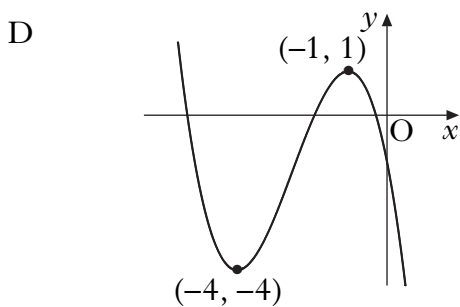
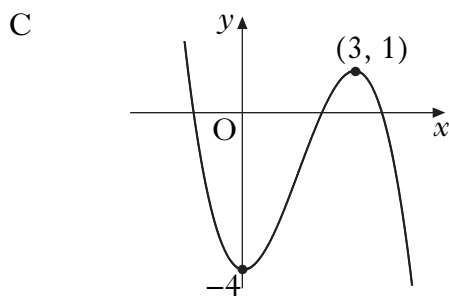
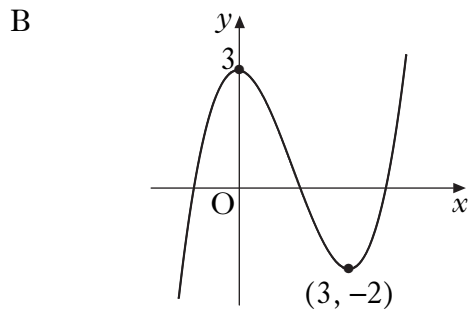
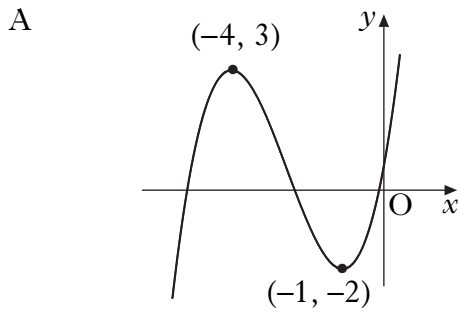

[Turn over

4. A tangent to the curve with equation $y = x^3 - 2x$ is drawn at the point $(2, 4)$.
What is the gradient of this tangent?
- A 2
B 3
C 4
D 10

5. If $x^2 - 8x + 7$ is written in the form $(x - p)^2 + q$, what is the value of q ?
- A -9
B -1
C 7
D 23

6. The point $P(2, -3)$ lies on the circle with centre C as shown.
The gradient of CP is -2 .
What is the equation of the tangent at P ?

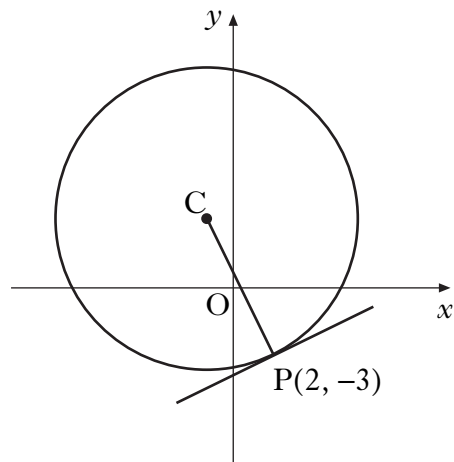

- A $y + 3 = -2(x - 2)$
B $y - 3 = -2(x + 2)$
C $y + 3 = \frac{1}{2}(x - 2)$
D $y - 3 = \frac{1}{2}(x + 2)$

7. A function f is defined on the set of real numbers by $f(x) = x^3 - x^2 + x + 3$.
What is the remainder when $f(x)$ is divided by $(x - 1)$?
- A 0
B 2
C 3
D 4

8. A line makes an angle of 30° with the positive direction of the x -axis as shown.

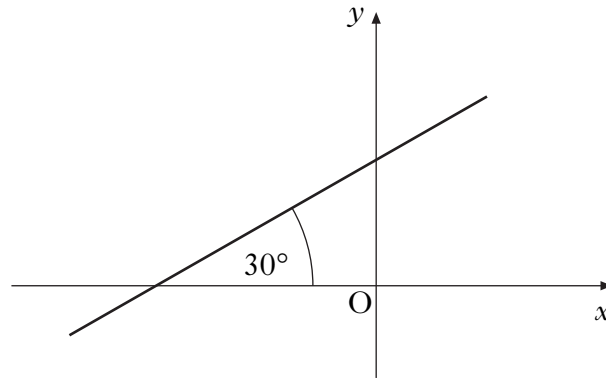

What is the gradient of the line?

- A $\frac{1}{\sqrt{3}}$
- B $\frac{1}{\sqrt{2}}$
- C $\frac{1}{2}$
- D $\frac{\sqrt{3}}{2}$
9. The discriminant of a quadratic equation is 23.
Here are two statements about this quadratic equation:
- (1) the roots are real;
 - (2) the roots are rational.

Which of the following is true?

- A Neither statement is correct.
- B Only statement (1) is correct.
- C Only statement (2) is correct.
- D Both statements are correct.

[Turn over

10. Solve $2 \cos x = \sqrt{3}$ for x , where $0 \leq x < 2\pi$.

A $\frac{\pi}{3}$ and $\frac{5\pi}{3}$

B $\frac{\pi}{3}$ and $\frac{2\pi}{3}$

C $\frac{\pi}{6}$ and $\frac{5\pi}{6}$

D $\frac{\pi}{6}$ and $\frac{11\pi}{6}$

11. Find $\int \left(4x^{\frac{1}{2}} + x^{-3} \right) dx$, where $x > 0$.

A $2x^{-\frac{1}{2}} - 3x^{-4} + c$

B $2x^{-\frac{1}{2}} - \frac{1}{2}x^{-2} + c$

C $\frac{8}{3}x^{\frac{3}{2}} - 3x^{-4} + c$

D $\frac{8}{3}x^{\frac{3}{2}} - \frac{1}{2}x^{-2} + c$

12. The diagram shows two right-angled triangles with sides and angles as given.

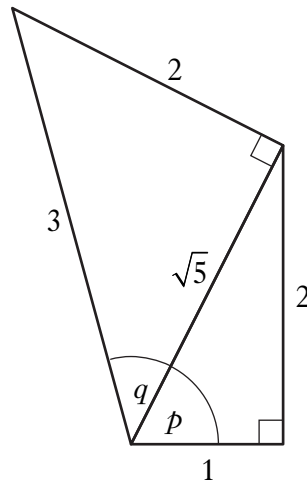

What is the value of $\sin(p + q)$?

- A $\frac{2}{\sqrt{5}} + \frac{2}{3}$
- B $\frac{2}{\sqrt{5}} + \frac{\sqrt{5}}{3}$
- C $\frac{2}{3} + \frac{2}{3\sqrt{5}}$
- D $\frac{4}{3\sqrt{5}} + \frac{1}{3}$
13. Given that $f(x) = 4 \sin 3x$, find $f'(0)$.

- A 0
- B 1
- C 12
- D 36

[Turn over

14. An equilateral triangle of side 3 units is shown.
The vectors \mathbf{p} and \mathbf{q} are as represented in the diagram.
What is the value of $\mathbf{p} \cdot \mathbf{q}$?

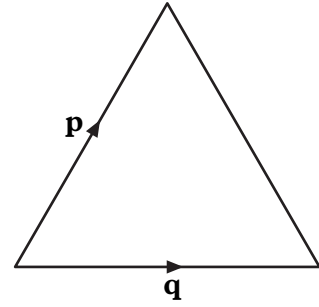

- A 9
B $\frac{9}{2}$
C $\frac{9}{\sqrt{2}}$
D 0
15. Given that the points $S(-4, 5, 1)$, $T(-16, -4, 16)$ and $U(-24, -10, 26)$ are collinear, calculate the ratio in which T divides SU .
- A 2 : 3
B 3 : 2
C 2 : 5
D 3 : 5

16. Find $\int \frac{1}{3x^4} dx$, where $x \neq 0$.

- A $-\frac{1}{9x^3} + c$
B $-\frac{1}{x^3} + c$
C $\frac{1}{x^3} + c$
D $\frac{1}{12x^3} + c$

17. The diagram shows the graph of a cubic.

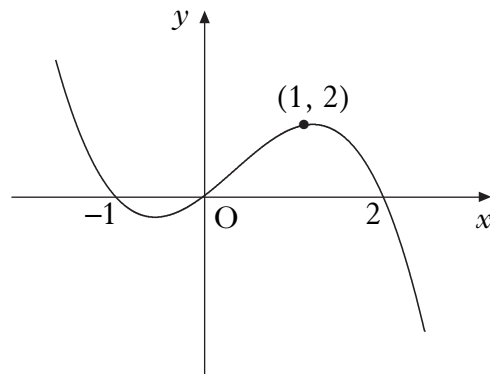

What is the equation of this cubic?

- A $y = -x(x + 1)(x - 2)$
 - B $y = -x(x - 1)(x + 2)$
 - C $y = x(x + 1)(x - 2)$
 - D $y = x(x - 1)(x + 2)$
18. If $f(x) = (x - 3)(x + 5)$, for what values of x is the graph of $y = f(x)$ above the x -axis?
- A $-5 < x < 3$
 - B $-3 < x < 5$
 - C $x < -5, x > 3$
 - D $x < -3, x > 5$

[Turn over

19. Which of the following diagrams represents the graph with equation $\log_3 y = x$?

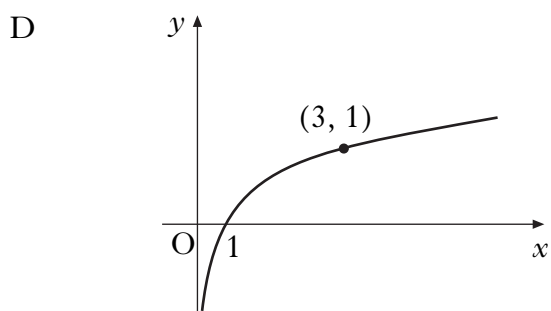
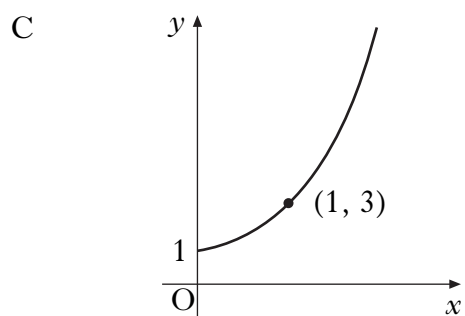
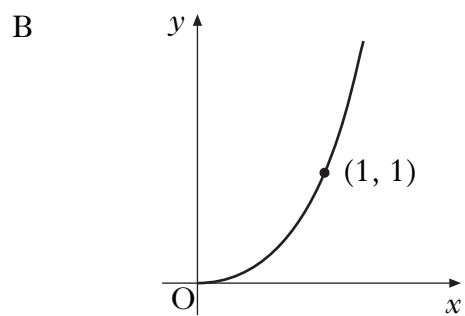
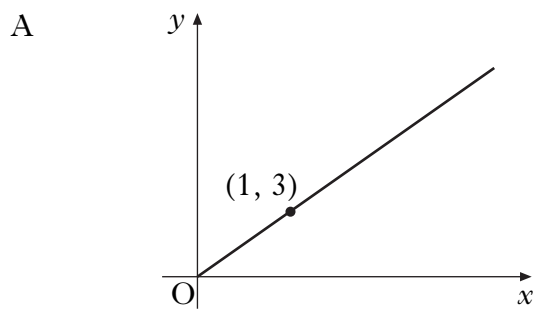

20. On a suitable domain, D, a function g is defined by $g(x) = \sin^2 \sqrt{x-2}$.

Which of the following gives the real values of x in D and the corresponding values of $g(x)$?

- A $x \geq 0$ and $-1 \leq g(x) \leq 1$
- B $x \geq 0$ and $0 \leq g(x) \leq 1$
- C $x \geq 2$ and $-1 \leq g(x) \leq 1$
- D $x \geq 2$ and $0 \leq g(x) \leq 1$

[END OF SECTION A]

[Turn over for SECTION B

SECTION B

ALL questions should be attempted.

21. A quadrilateral has vertices $A(-1, 8)$, $B(7, 12)$, $C(8, 5)$ and $D(2, -3)$ as shown in the diagram.

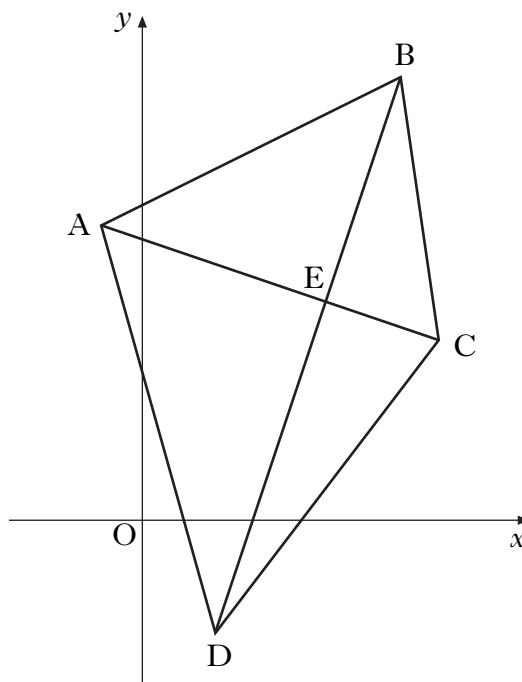

- (a) Find the equation of diagonal BD . 2
- (b) The equation of diagonal AC is $x + 3y = 23$.
Find the coordinates of E , the point of intersection of the diagonals. 3
- (c) (i) Find the equation of the perpendicular bisector of AB .
(ii) Show that this line passes through E . 5

22. A function f is defined on the set of real numbers by $f(x) = (x - 2)(x^2 + 1)$.
- (a) Find where the graph of $y = f(x)$ cuts:
- (i) the x -axis;
 - (ii) the y -axis. 2
- (b) Find the coordinates of the stationary points on the curve with equation $y = f(x)$ and determine their nature. 8
- (c) On separate diagrams sketch the graphs of:
- (i) $y = f(x)$;
 - (ii) $y = -f(x)$. 3
23. (a) Solve $\cos 2x^\circ - 3 \cos x^\circ + 2 = 0$ for $0 \leq x < 360$. 5
- (b) Hence solve $\cos 4x^\circ - 3 \cos 2x^\circ + 2 = 0$ for $0 \leq x < 360$. 2

[END OF SECTION B]

[END OF QUESTION PAPER]