

# X100/301

---

NATIONAL  
QUALIFICATIONS 2010

FRIDAY, 21 MAY  
9.00 AM – 10.30 AM

MATHEMATICS  
HIGHER  
Paper 1  
(Non-calculator)

**Read carefully**

**Calculators may NOT be used in this paper.**

**Section A – Questions 1–20 (40 marks)**

Instructions for completion of **Section A** are given on page two.

For this section of the examination you must use an **HB pencil**.

**Section B (30 marks)**

- 1 Full credit will be given only where the solution contains appropriate working.
- 2 Answers obtained by readings from scale drawings will not receive any credit.



## Read carefully

- 1 Check that the answer sheet provided is for **Mathematics Higher (Section A)**.
- 2 For this section of the examination you must use an **HB pencil** and, where necessary, an eraser.
- 3 Check that the answer sheet you have been given has **your name, date of birth, SCN** (Scottish Candidate Number) and **Centre Name** printed on it.  
Do not change any of these details.
- 4 If any of this information is wrong, tell the Invigilator immediately.
- 5 If this information is correct, **print** your name and seat number in the boxes provided.
- 6 The answer to each question is **either** A, B, C or D. Decide what your answer is, then, using your pencil, put a horizontal line in the space provided (see sample question below).
- 7 There is **only one correct** answer to each question.
- 8 Rough working should **not** be done on your answer sheet.
- 9 At the end of the exam, put the **answer sheet for Section A inside the front cover of your answer book**.

## Sample Question

A curve has equation  $y = x^3 - 4x$ .

What is the gradient at the point where  $x = 2$ ?

- A 8
- B 1
- C 0
- D -4

The correct answer is **A**—8. The answer **A** has been clearly marked in **pencil** with a horizontal line (see below).

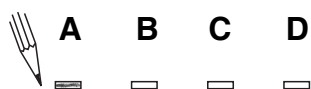

## Changing an answer

If you decide to change your answer, carefully erase your first answer and, using your pencil, fill in the answer you want. The answer below has been changed to **D**.

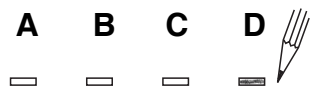

## FORMULAE LIST

### Circle:

The equation  $x^2 + y^2 + 2gx + 2fy + c = 0$  represents a circle centre  $(-g, -f)$  and radius  $\sqrt{g^2 + f^2 - c}$ .

The equation  $(x - a)^2 + (y - b)^2 = r^2$  represents a circle centre  $(a, b)$  and radius  $r$ .

**Scalar Product:**  $\mathbf{a} \cdot \mathbf{b} = |\mathbf{a}| |\mathbf{b}| \cos \theta$ , where  $\theta$  is the angle between  $\mathbf{a}$  and  $\mathbf{b}$

or  $\mathbf{a} \cdot \mathbf{b} = a_1 b_1 + a_2 b_2 + a_3 b_3$  where  $\mathbf{a} = \begin{pmatrix} a_1 \\ a_2 \\ a_3 \end{pmatrix}$  and  $\mathbf{b} = \begin{pmatrix} b_1 \\ b_2 \\ b_3 \end{pmatrix}$ .

**Trigonometric formulae:**  $\sin(A \pm B) = \sin A \cos B \pm \cos A \sin B$

$$\cos(A \pm B) = \cos A \cos B \mp \sin A \sin B$$

$$\sin 2A = 2 \sin A \cos A$$

$$\cos 2A = \cos^2 A - \sin^2 A$$

$$= 2 \cos^2 A - 1$$

$$= 1 - 2 \sin^2 A$$

**Table of standard derivatives:**

$f(x)$	$f'(x)$
$\sin ax$	$a \cos ax$
$\cos ax$	$-a \sin ax$

**Table of standard integrals:**

$f(x)$	$\int f(x) dx$
$\sin ax$	$-\frac{1}{a} \cos ax + C$
$\cos ax$	$\frac{1}{a} \sin ax + C$

[Turn over

SECTION A

ALL questions should be attempted.

1. A line L is perpendicular to the line with equation  $2x - 3y - 6 = 0$ .

What is the gradient of the line L?

A  $-\frac{3}{2}$

B  $-\frac{1}{2}$

C  $\frac{2}{3}$

D 2

2. A sequence is defined by the recurrence relation  $u_{n+1} = 2u_n + 3$  and  $u_0 = 1$ .

What is the value of  $u_2$ ?

A 7

B 10

C 13

D 16

3. Given that  $\mathbf{u} = \begin{pmatrix} 2 \\ 0 \\ 1 \end{pmatrix}$  and  $\mathbf{v} = \begin{pmatrix} -1 \\ 2 \\ 4 \end{pmatrix}$ , find  $3\mathbf{u} - 2\mathbf{v}$  in component form.

A  $\begin{pmatrix} 4 \\ -1 \\ -5 \end{pmatrix}$

B  $\begin{pmatrix} 4 \\ -4 \\ 11 \end{pmatrix}$

C  $\begin{pmatrix} 8 \\ -1 \\ 5 \end{pmatrix}$

D  $\begin{pmatrix} 8 \\ -4 \\ -5 \end{pmatrix}$

4. The diagram shows the graph with equation of the form  $y = a\cos bx$  for  $0 \leq x \leq 2\pi$ .

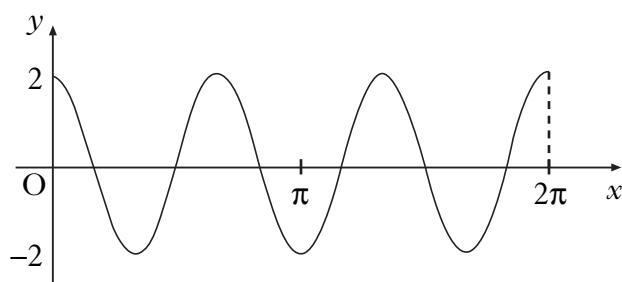

What is the equation of this graph?

- A  $y = 2\cos 3x$
  - B  $y = 2\cos 2x$
  - C  $y = 3\cos 2x$
  - D  $y = 4\cos 3x$
5. When  $x^2 + 8x + 3$  is written in the form  $(x + p)^2 + q$ , what is the value of  $q$ ?
- A  $-19$
  - B  $-13$
  - C  $-5$
  - D  $19$

**[Turn over**

6. The roots of the equation  $kx^2 - 3x + 2 = 0$  are equal.

What is the value of  $k$ ?

- A  $-\frac{9}{8}$
- B  $-\frac{8}{9}$
- C  $\frac{8}{9}$
- D  $\frac{9}{8}$

7. A sequence is generated by the recurrence relation  $u_{n+1} = \frac{1}{4}u_n + 7$ , with  $u_0 = -2$ .

What is the limit of this sequence as  $n \rightarrow \infty$ ?

- A  $\frac{1}{28}$
- B  $\frac{28}{5}$
- C  $\frac{28}{3}$
- D 28

8. The equation of the circle shown in the diagram is  $x^2 + y^2 - 6x - 10y + 9 = 0$ .  
The  $x$ -axis and the line  $l$  are parallel tangents to the circle.

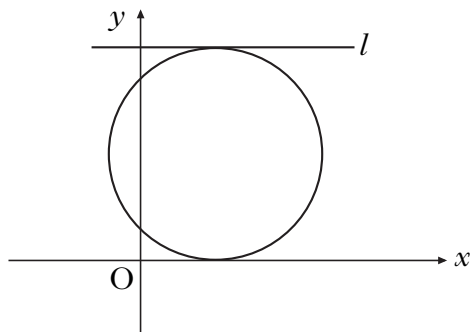

What is the equation of line  $l$ ?

- A  $y = 5$   
B  $y = 10$   
C  $y = 18$   
D  $y = 20$
9. Find  $\int (2x^{-4} + \cos 5x) dx$ .
- A  $-\frac{2}{5}x^{-5} - 5\sin 5x + c$   
B  $-\frac{2}{5}x^{-5} + \frac{1}{5}\sin 5x + c$   
C  $-\frac{2}{3}x^{-3} + \frac{1}{5}\sin 5x + c$   
D  $-\frac{2}{3}x^{-3} - 5\sin 5x + c$
10. The vectors  $x\mathbf{i} + 5\mathbf{j} + 7\mathbf{k}$  and  $-3\mathbf{i} + 2\mathbf{j} - \mathbf{k}$  are perpendicular.  
What is the value of  $x$ ?
- A 0  
B 1  
C  $\frac{4}{3}$   
D  $\frac{10}{3}$

[Turn over

11. Functions  $f$  and  $g$  are defined on suitable domains by  $f(x) = \cos x$  and  $g(x) = x + \frac{\pi}{6}$ .

What is the value of  $f\left(g\left(\frac{\pi}{6}\right)\right)$ ?

A  $\frac{1}{2} + \frac{\pi}{6}$

B  $\frac{\sqrt{3}}{2} + \frac{\pi}{6}$

C  $\frac{\sqrt{3}}{2}$

D  $\frac{1}{2}$

12. If  $f(x) = \frac{1}{\sqrt[5]{x}}$ ,  $x \neq 0$ , what is  $f'(x)$ ?

A  $-\frac{1}{5}x^{-\frac{6}{5}}$

B  $-\frac{1}{5}x^{-\frac{4}{5}}$

C  $-\frac{5}{2}x^{-\frac{7}{2}}$

D  $-\frac{5}{2}x^{-\frac{3}{2}}$

13. Which of the following diagrams shows a parabola with equation  $y = ax^2 + bx + c$ , where

- $a > 0$
- $b^2 - 4ac > 0$ ?

A

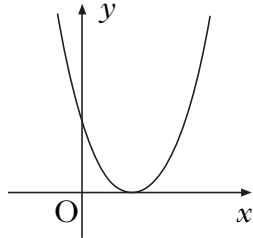

B

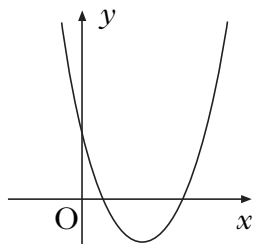

C

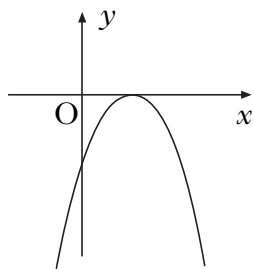

D

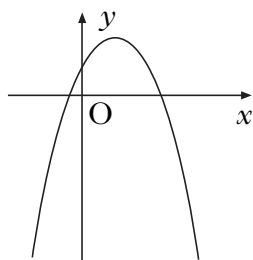

[Turn over

14. The diagram shows graphs with equations  $y = 14 - x^2$  and  $y = 2x^2 + 2$ .

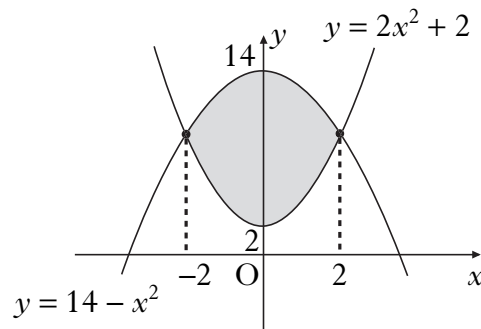

Which of the following represents the shaded area?

- A  $\int_2^{14} (12 - 3x^2) dx$
- B  $\int_2^{14} (3x^2 - 12) dx$
- C  $\int_{-2}^2 (12 - 3x^2) dx$
- D  $\int_{-2}^2 (3x^2 - 12) dx$
15. The derivative of a function  $f$  is given by  $f'(x) = x^2 - 9$ .  
Here are two statements about  $f$ :
- (1)  $f$  is increasing at  $x = 1$ ;  
(2)  $f$  is stationary at  $x = -3$ .

Which of the following is true?

- A Neither statement is correct.  
B Only statement (1) is correct.  
C Only statement (2) is correct.  
D Both statements are correct.

16. The diagram shows the graph with equation  $y = k(x - 1)^2(x + t)$ .

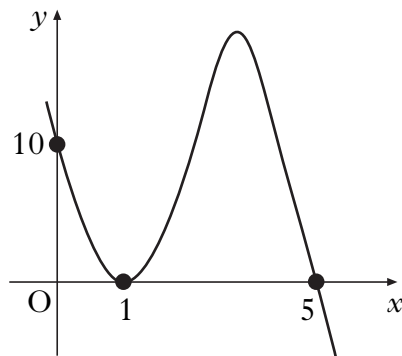

What are the values of  $k$  and  $t$ ?

	$k$	$t$
A	-2	-5
B	-2	5
C	2	-5
D	2	5

17. If  $s(t) = t^2 - 5t + 8$ , what is the rate of change of  $s$  with respect to  $t$  when  $t = 3$ ?
- A -5  
B 1  
C 2  
D 9
18. What is the solution of  $x^2 + 4x > 0$ , where  $x$  is a real number?
- A  $-4 < x < 0$   
B  $x < -4, x > 0$   
C  $0 < x < 4$   
D  $x < 0, x > 4$

[Turn over

19. The diagram shows the graph of  $y = f(x)$  where  $f$  is a logarithmic function.

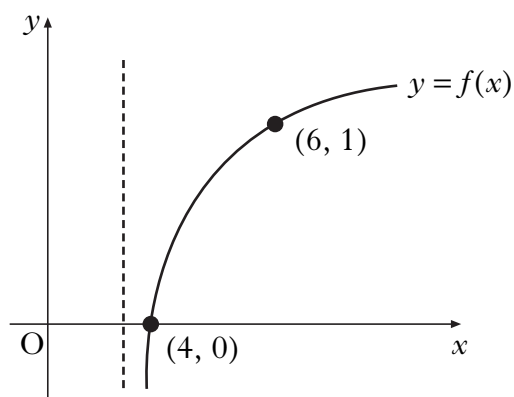

What is  $f(x)$ ?

- A  $f(x) = \log_6(x - 3)$
  - B  $f(x) = \log_3(x + 3)$
  - C  $f(x) = \log_3(x - 3)$
  - D  $f(x) = \log_6(x + 3)$
20. The diagram shows the graph of  $y = f(2x) - 3$ .

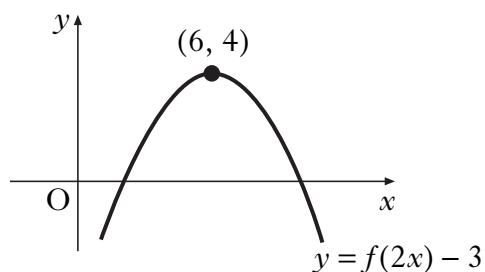

What are the coordinates of the turning point on the graph of  $y = f(x)$ ?

- A  $(12, 7)$
- B  $(12, 1)$
- C  $(3, 7)$
- D  $(3, 1)$

[END OF SECTION A]

## SECTION B

ALL questions should be attempted.

21. Triangle ABC has vertices A(4, 0), B(-4, 16) and C(18, 20), as shown in the diagram opposite.

Medians AP and CR intersect at the point T(6, 12).

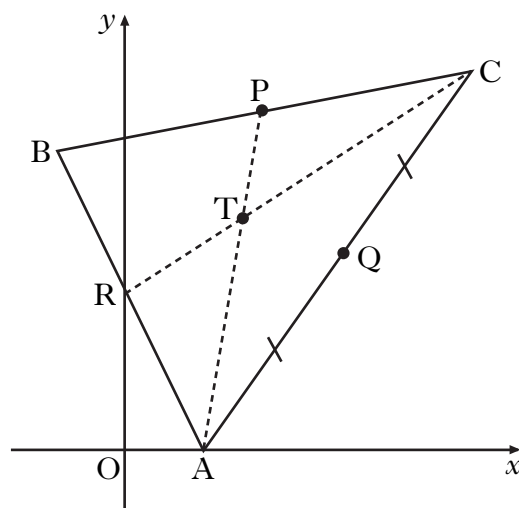

- (a) Find the equation of median BQ. 3
- (b) Verify that T lies on BQ. 1
- (c) Find the ratio in which T divides BQ. 2
22. (a) (i) Show that  $(x - 1)$  is a factor of  $f(x) = 2x^3 + x^2 - 8x + 5$ . 5
- (ii) Hence factorise  $f(x)$  fully. 1
- (b) Solve  $2x^3 + x^2 - 8x + 5 = 0$ . 5
- (c) The line with equation  $y = 2x - 3$  is a tangent to the curve with equation  $y = 2x^3 + x^2 - 6x + 2$  at the point G. 1
- Find the coordinates of G. 5
- (d) This tangent meets the curve again at the point H. 1
- Write down the coordinates of H. 1

[Turn over for Question 23 on Page fourteen

23. (a) Diagram 1 shows a right angled triangle, where the line OA has equation  $3x - 2y = 0$ .

(i) Show that  $\tan a = \frac{3}{2}$ .

(ii) Find the value of  $\sin a$ .

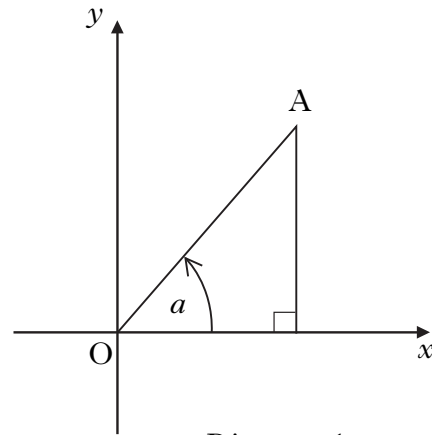

Diagram 1

4

(b) A second right angled triangle is added as shown in Diagram 2.

The line OB has equation  $3x - 4y = 0$ .

Find the values of  $\sin b$  and  $\cos b$ .

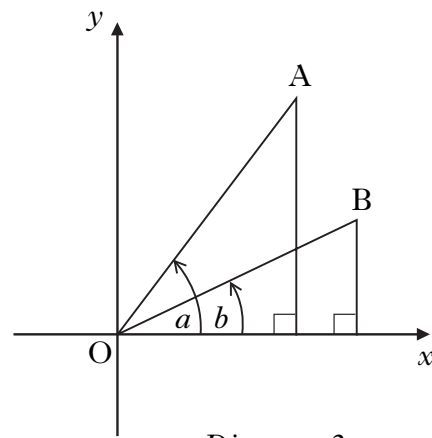

Diagram 2

4

(c) (i) Find the value of  $\sin(a - b)$ .

(ii) State the value of  $\sin(b - a)$ .

4

[END OF SECTION B]

[END OF QUESTION PAPER]