

1. Marks must be assigned in accordance with these marking instructions. In principle, marks are awarded for what is correct, rather than marks deducted for what is wrong.
2. Award one mark for each 'bullet' point. Each error should be underlined in RED at the point in the working where it first occurs, and not at any subsequent stage of the working.
3. The working subsequent to an error must be followed through by the marker with possible full marks for the subsequent working, provided that the difficulty involved is approximately similar. Where, subsequent to an error, the working is eased, a deduction(s) of mark(s) should be made.
This may happen where a question is divided into parts. In fact, failure to even answer an earlier section does not preclude a candidate from assuming the result of that section and obtaining full marks for a later section.
4. Correct working should be ticked (✓). This is essential for later stages of the SQA procedures. Where working subsequent to an error(s) is correct and scores marks, it should be marked with a crossed tick (✗). In appropriate cases attention may be directed to work which is not quite correct (e.g. bad form) but which has not been penalised, by underlining with a dotted or wavy line.
Work which is correct but inadequate to score any marks should be corrected with a double cross tick (✘).
5.
 - The total mark for each section of a question should be entered in red in the **outer** right hand margin, opposite the end of the working concerned.
 - Only the mark should be written, **not** a fraction of the possible marks.
 - These marks should correspond to those on the question paper and these instructions.
6. It is of great importance that the utmost care should be exercised in adding up the marks. Where appropriate, all summations for totals and grand totals must be carefully checked.
Where a candidate has scored zero marks for any question attempted, "0" should be shown against the answer.
7. As indicated on the front of the question paper, full credit should only be given where the solution contains appropriate working. Accept answers arrived at by inspection or mentally where it is possible for the answer so to have been obtained. Situations where you may accept such working will be indicated in the marking instructions.

cont/

8. Do not penalise:
 - working subsequent to a correct answer
 - omission of units
 - bad form
 - legitimate variations in numerical answers
 - correct working in the “wrong” part of a question
9. No piece of work should be scored through - even where a fundamental misunderstanding is apparent early in the answer. Reference should always be made to the marking scheme - answers which are widely off-beam are unlikely to include anything of relevance but in the vast majority of cases candidates still have the opportunity of gaining the odd mark or two provided it satisfies the criteria for the mark(s).
10. If in doubt between two marks, give an intermediate mark, but without fractions. When in doubt between consecutive numbers, give the higher mark.
11. In cases of difficulty covered neither in detail nor in principle in the Instructions, attention may be directed to the assessment of particular answers by making a referral to the P.A. Please see the general instructions for P.A. referrals.
12. No marks should be deducted at this stage for careless or badly arranged work. In cases where the writing or arrangement is very bad, a note may be made on the upper left-hand corner of the front cover of the script.
- 13 **Do not write any comments on the scripts.** A summary of acceptable notation is given on page 4.

Summary

Throughout the examination procedures many scripts are remarked. It is essential that markers follow common procedures:

- 1 **Tick** correct working.
- 2 Put a mark in the **right-hand margin to match the marks allocations on the question paper.**
- 3 Do **not** write marks as fractions.
- 4 Put each mark **at the end** of the candidate’s response to the question.
- 5 **Follow through** errors to see if candidates can score marks subsequent to the error.
- 6 Do **not** write any comments on the scripts.

1 (a) The diagram shows line OA with equation $x - 2y = 0$.
 The angle between OA and the x -axis is a° .
 Find the value of a . **3**

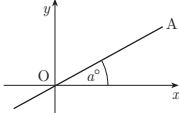

(b) The second diagram shows lines OA and OB. The angle between these two lines is 30° .
 Calculate the gradient of line OB correct to 1 decimal place. **1**

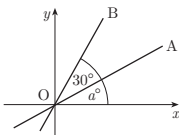

Qu.	part	marks	Grade	Syllabus Code	Calculator class	Source
1	a	3	C	1.1.3	CR	04/81
	b	1	C	1.1.3		

The Primary Method m/s is based on the following generic m/s. THIS GENERIC M/S MAY BE USED AS AN EQUIVALENCE GUIDE BUT ONLY WHERE A CANDIDATE DOES NOT USE THE PRIMARY METHOD OR ANY ALTERNATIVE METHOD SHOWN IN DETAIL IN THE MARKING SCHEME.

- ¹ ic : find gradient of a line
- ² ss : know gradient =tan(angle) and apply
- ³ pd : process
- ⁴ pd : process angle=tan⁻¹(angle)

Primary Method : Give 1 mark for each •

- ¹ gradient = $\frac{1}{2}$
- ² $\tan a^\circ = \text{gradient}$ stated or implied by •³
- ³ $\tan^{-1}\left(\frac{1}{2}\right) = 26.6^\circ$ 3 marks
- ⁴ $m_2 = \tan(30 + 26.6)^\circ = 1.5$ 1 mark

1	Common Error no.1
$m = -2$	× •1
$\tan a^\circ = m$	✓ •2
$a = \tan^{-1}(-2) = 116.6$	✓ •3

2	Common Error no.2
$m = 1$	× •1
$\tan a^\circ = m$	✓ •2
$a = \tan^{-1}(1) = 45$	✓ •3

3	Common Error no.3
$m = -2$	× •1
$\tan a^\circ = m$	✓ •2
$a = \tan^{-1}(-2) = -63.4 \text{ or } 63.4$	× •3

Notes

- 1 Accept any answer in (a) rounded correctly, so that e.g. if $a = 27^\circ$ (OK)
 $m_{OB} = \tan(30+27)^\circ = 1.5$
- 2 A candidate who states $m = \tan \theta$, and does not go on to use it, cannot be awarded •2.
- 3 Treat $\tan\left(\frac{1}{2}\right) = 26.6^\circ$ as very bad form.
- 4 In (b) do not penalise “not rounding to 1 d.p.” but accept any correct answer which rounds to 1.5

2 P, Q and R have coordinates (1, 3, -1), (2, 0, 1) and (-3, 1, 2) respectively.

(a) Express the vectors \vec{QP} and \vec{QR} in component form. 2

(b) Hence or otherwise find the size of angle PQR. 5

Qu.	part	marks	Grade	Syllabus Code	Calculator class	Source
2	a	2	C	3.1.8	CR	04/117
	b	5	C	3.1.9, 3.1.11		

The Primary Method m/s is based on the following generic m/s. THIS GENERIC M/S MAY BE USED AS AN EQUIVALENCE GUIDE BUT ONLY WHERE A CANDIDATE DOES NOT USE THE PRIMARY METHOD OR ANY ALTERNATIVE METHOD SHOWN IN DETAIL IN THE MARKING SCHEME.

- ¹ ic : interpret coordinates to vectors
- ² ic : interpret coordinates to vectors
- ³ ss : know to use eg scalar product
- ⁴ pd : process scalar product
- ⁵ pd : process length
- ⁶ pd : process length
- ⁷ pd : process angle

Note

1 in (a)

For calculating \vec{PQ} and \vec{RQ} , award 1 mark (out of 2)

2 in (a)

Treat e.g. (-1, 3, -2) as bad form

3 For candidates who do not attempt •7 : the formula quoted at •3 in both methods must relate to the labelling in the question to earn •3

Primary Method : Give 1 mark for each •

•¹ $\vec{QP} = \begin{pmatrix} -1 \\ 3 \\ -2 \end{pmatrix}$

•² $\vec{QR} = \begin{pmatrix} -5 \\ 1 \\ 1 \end{pmatrix}$

2 marks

•³ $\cos PQR = \frac{\vec{QP} \cdot \vec{QR}}{|\vec{QP}| |\vec{QR}|}$ stated or implied by •7

•⁴ $\vec{QP} \cdot \vec{QR} = 6$

•⁵ $|\vec{QP}| = \sqrt{14}$

•⁶ $|\vec{QR}| = \sqrt{27}$

•⁷ $P\hat{Q}R = 72.0^\circ$

5 marks

Alternative Method 1 for •3 and •7

•³ $\cos P\hat{Q}R = \frac{p^2 + r^2 - q^2}{2pr}$ stated or implied by •7

•⁴ $q = \sqrt{29}$

•⁵ $r = \sqrt{14}$

•⁶ $p = \sqrt{27}$

•⁷ $P\hat{Q}R = 72.0^\circ$

5 marks

CONTINUED

2 P, Q and R have coordinates (1, 3, -1), (2, 0, 1) and (-3, 1, 2) respectively.

(a) Express the vectors \vec{QP} and \vec{QR} in component form.

2

(b) Hence or otherwise find the size of angle PQR.

5

Qu.	part	marks	Grade	Syllabus Code	Calculator class	Source
2	a	2	C	3.1.8	CR	04/117
	b	5	C	3.1.9, 3.1.11		

3 Common errors no.1

•³ $\cos POR = \frac{\vec{OP} \cdot \vec{OR}}{|\vec{OP}| |\vec{OR}|}$ stated or implied by •7

•⁴ $\vec{OP} \cdot \vec{OR} = -2$

•⁵ $|\vec{OP}| = \sqrt{11}$

•⁶ $|\vec{OR}| = \sqrt{14}$

•⁷ $\hat{P}OR = 99.3^\circ$ or 1.733°

4 marks awarded : deduct 1 per error

4 Common errors no.2

•³ $\cos QOR = \frac{\vec{OQ} \cdot \vec{OR}}{|\vec{OQ}| |\vec{OR}|}$ stated or implied by •7

•⁴ $\vec{OQ} \cdot \vec{OR} = -4$

•⁵ $|\vec{OQ}| = \sqrt{5}$

•⁶ $|\vec{OR}| = \sqrt{14}$

•⁷ $\hat{Q}OR = 118.6^\circ$ or 2.069°

3 marks awarded : deduct 1 per error

5 Common errors no.3

•³ $\cos QOP = \frac{\vec{OQ} \cdot \vec{OP}}{|\vec{OQ}| |\vec{OP}|}$ stated or implied by •7

•⁴ $\vec{OQ} \cdot \vec{OP} = 1$

•⁵ $|\vec{OQ}| = \sqrt{11}$

•⁶ $|\vec{OP}| = \sqrt{5}$

•⁷ $\hat{Q}OR = 82.3^\circ$ or 1.436°

3 marks awarded : deduct 1 per error

6 Common errors no.4

•³ $\cos \hat{P}RQ = \frac{\vec{RP} \cdot \vec{RQ}}{|\vec{RP}| |\vec{RQ}|}$ stated or implied by •7

•⁴ $\vec{RP} \cdot \vec{RQ} = 21$

•⁵ $|\vec{RP}| = \sqrt{29}$

•⁶ $|\vec{RQ}| = \sqrt{27}$

•⁷ $\hat{P}RQ = 41.4^\circ$ or 0.722°

3 marks awarded : deduct 1 per error

7 Common errors no.5

•³ $\cos \hat{R}PQ = \frac{\vec{PR} \cdot \vec{PQ}}{|\vec{PR}| |\vec{PQ}|}$ stated or implied by •7

•⁴ $\vec{PR} \cdot \vec{PQ} = 8$

•⁵ $|\vec{PR}| = \sqrt{14}$

•⁶ $|\vec{PQ}| = \sqrt{29}$

•⁷ $\hat{R}PQ = 66.6^\circ$ or 1.163°

3 marks awarded : deduct 1 per error

3 Prove that the roots of the equation $2x^2 + px - 3 = 0$ are real for all values of p .

4

Qu.	part	marks	Grade	Syllabus Code	Calculator class	Source
3		4	C,B	1.3.4, 1.1.6	CN	03/85

The Primary Method m/s is based on the following generic m/s. THIS GENERIC M/S MAY BE USED AS AN EQUIVALENCE GUIDE BUT ONLY WHERE A CANDIDATE DOES NOT USE THE PRIMARY METHOD OR ANY ALTERNATIVE METHOD SHOWN IN DETAIL IN THE MARKING SCHEME.

- ¹ ss : know/use discriminant
- ² ic : identify discriminant
- ³ pd : simplify
- ⁴ ic : complete proof

Primary Method : Give 1 mark for each •

- ¹ *know to show* $b^2 - 4ac \geq 0$
- ² $p^2 - 4 \times 2 \times (-3)$
- ³ $p^2 + 24$
- ⁴ p^2 is positive
so $\Delta \geq 0$ and roots real

4 marks

Note

- 1 Evidence for •¹ will more than likely appear at the •⁴ stage.
- 2 Treat $b^2 - 4ac > 0$ as bad form

1 Alternative Method 1

- ¹ $x = \frac{-p \pm \sqrt{(-p)^2 - 4 \times 2 \times (-3)}}{4}$
- ² $x = \frac{-p \pm \sqrt{p^2 + 24}}{4}$
- ³ we need $p^2 + 24 \geq 0$
- ⁴ p^2 is positive and so roots real

4 marks

4	A sequence is defined by the recurrence relation $u_{n+1} = ku_n + 3$.	
(a)	Write down the condition on k for this sequence to have a limit.	1
(b)	The sequence tends to a limit of 5 as $n \rightarrow \infty$. Determine the value of k .	3

Qu.	part	marks	Grade	Syllabus Code	Calculator class	Source
4	a	1	C	1.4.3	CN	04/16
	b	3	B	1.4.3		

The Primary Method m/s is based on the following generic m/s. THIS GENERIC M/S MAY BE USED AS AN EQUIVALENCE GUIDE BUT ONLY WHERE A CANDIDATE DOES NOT USE THE PRIMARY METHOD OR ANY ALTERNATIVE METHOD SHOWN IN DETAIL IN THE MARKING SCHEME.

- ¹ ic : state condition for limit
- ² ss : know how to find limit
- ³ ic : substitute
- ⁴ pd : process

Primary Method : Give 1 mark for each •

- ¹ $-1 < k < 1$ 1 mark
- ² $l = \frac{b}{1-a}$ *stated or implied by* •³
- ³ $5 = \frac{3}{1-k}$
- ⁴ $k = \frac{2}{5}$ 3 marks

1 Alternative Method : no.1

- ¹ $-1 < k < 1$ 1 mark
- ² $L = kL + 3$ *stated or implied by* •³
- ³ $5 = 5k + 3$
- ⁴ $k = \frac{2}{5}$ 3 marks

Notes

- 1 $-1 \leq k \leq 1$ does not gain •¹
 but
 accept “between -1 and 1” for •¹
 accept $|k| < 1$ for •¹

 $-1 < a < 1$ does not gain •1 unless it has been replaced by k in subsequent working in (b)
- 2 Guess and check :
 Guessing $k = 0.4$ and checking algebraically that this does yield a limit of 5 may be awarded 2 marks
- 3 Guess and check :
 Guessing $k = 0.4$ and checking iteratively that this does yield a limit of 5 may be awarded 1 mark
- 4 No working :
 Simply stating that $k = 0.4$ earns no marks
- 5 Wrong formula :
 Work using an incorrect “formula” leading to a valid value of k may be awarded 1 mark.

- 5 The point $P(x, y)$ lies on the curve with equation $y = 6x^2 - x^3$.
- (a) Find the value of x for which the gradient of the tangent at P is 12. 5
- (b) Hence find the equation of the tangent at P. 2

Qu.	part	marks	Grade	Syllabus Code	Calculator class	Source
5	a	5	C	1.3.2, 1.3.9	CN	04/96
	b	2	C	1.1.6		

The Primary Method m/s is based on the following generic m/s.
 THIS GENERIC M/S MAY BE USED AS AN EQUIVALENCE GUIDE
 BUT ONLY WHERE A CANDIDATE DOES NOT USE THE PRIMARY
 METHOD OR ANY ALTERNATIVE METHOD SHOWN IN DETAIL IN
 THE MARKING SCHEME.

- ¹ ss : know to differentiate
- ² pd : differentiate
- ³ ss : set derivative = gradient
- ⁴ pd : start to solve
- ⁵ pd : process
- ⁶ pd : process
- ⁷ ic : state equation of tangent

Primary Method : Give 1 mark for each •

- ¹ $\frac{dy}{dx} =$ *stated or implied by* •²
- ² $12x - 3x^2$
- ³ $12x - 3x^2 = 12$
- ⁴ $3(x - 2)^2 = 0$
- ⁵ $x = 2$ 5 marks
- ⁶ $y = 16$
- ⁷ $y - 16 = 12(x - 2)$ 2 marks

1 Common error no.1

- ¹ $\sqrt{\frac{dy}{dx}} =$ *stated or implied by* •²
- ² $\sqrt{12x - 3x^2}$
- ³ $\times 12x - 3x^2 = 0$
- ⁴ $\times 3x(4 - x)$
- ⁵ $\times x = 0$ and $x = 4$ 2 marks awarded
- ⁶ $\sqrt{x = 4} \Rightarrow y = 32$
- ⁷ $\sqrt{y - 32} = 12(x - 4)$ 2 marks awarded

Notes

- 1 For $\frac{dy}{dx} = 12x - 3x^2$
 $12x - 3x^2 = 12$
 followed by a guess of $x = 2$ and no check, only
 •¹,•² and •³ can be awarded.
- 2 For $\frac{dy}{dx} = 12x - 3x^2$
 $12x - 3x^2 = 12$
 followed by a guess of $x = 2$ and a check that does
 in fact yield 12, •¹,•²,•³ and •⁴ can be awarded.

6	(a)	Express $3\cos(x^\circ) + 5\sin(x^\circ)$ in the form $k\cos(x^\circ - a^\circ)$ where $k > 0$ and $0 \leq a \leq 90$.	4
	(b)	Hence solve the equation $3\cos(x^\circ) + 5\sin(x^\circ) = 4$ for $0 \leq x \leq 90$.	3

Qu.	part	marks	Grade	Syllabus Code	Calculator class	Source
6	a	4	C	3.4.2	CR	04/122
6	b	3	B	3.4.2	CR	

The Primary Method m/s is based on the following generic m/s. THIS GENERIC M/S MAY BE USED AS AN EQUIVALENCE GUIDE BUT ONLY WHERE A CANDIDATE DOES NOT USE THE PRIMARY METHOD OR ANY ALTERNATIVE METHOD SHOWN IN DETAIL IN THE MARKING SCHEME.

- ¹ ss : expand
- ² ic : equate coefficients
- ³ pd : solve for k
- ⁴ pd : solve for a
- ⁵ ss : use transformed function
- ⁶ pd : solve trig equation for " $x - a$ "
- ⁷ pd : solve for x

Primary Method : Give 1 mark for each •	
• ¹ $k\cos x \cos a + k\sin x \sin a$	STATED EXPLICITLY
• ² $k\cos a = 3, k\sin a = 5$	STATED EXPLICITLY
• ³ $k = \sqrt{34}$	
• ⁴ $a = 59$	
	4 marks
• ⁵ $\sqrt{34}\cos(x - 59)^\circ = 4$	
• ⁶ $x - 59 = \text{any one of}$ $-46 \cdot 7, 46 \cdot 7, 313.3$	
• ⁷ $x = 12 \cdot 3$	
	3 marks

Note

- 1 Using $k\cos(x^\circ + a^\circ)$ etc:
candidates may use any form of wave equation to start with, as long as their answer is in the form $k\cos(x - a)$.
If it is not, then •⁴ is not available.
- 2 $k(\cos x \cos a + \sin x \sin a)$ is OK for •¹
- 3 $\sqrt{34}\cos x \cos a + \sqrt{34}\sin x \sin a$ is OK for •¹
- 4 Treat $k\cos x \cos a + \sin x \sin a$ as bad form provided •² is gained
- 5 Accept answers which round to 5.8 for k at •³
- 6 For •⁴, accept any answer which rounds to 59
- 7 Using $k\cos a = 5, k\sin a = 3$, leads to $a = 31$.
Only marks •¹, •³ and •⁴ are available

1	Alternative Method 1
• ¹	strategy : r / a triangle 3,5, $\sqrt{34}$
• ²	$\sqrt{34}\left(\cos x \cdot \frac{3}{\sqrt{34}} + \sin x \cdot \frac{5}{\sqrt{34}}\right)$
• ³	$\sqrt{34}(\cos x \cdot \cos a + \sin x \cdot \sin a)$ and $\tan a = \frac{5}{3}$
• ⁴	$a = 59^\circ$
	4 marks

CONTINUED

6	(a)	Express $3\cos(x^\circ) + 5\sin(x^\circ)$ in the form $k\cos(x^\circ - a^\circ)$ where $k > 0$ and $0 \leq a \leq 90$.	4
	(b)	Hence solve the equation $3\cos(x^\circ) + 5\sin(x^\circ) = 4$ for $0 \leq x \leq 90$.	3

Qu.	part	marks	Grade	Syllabus Code	Calculator class	Source
6	a	4	C	3.4.2	CR	04/122
6	b	3	B	3.4.2	CR	

2	Common wrong solution
• ¹ ✓	$k\cos x \cos a + k\sin x \sin a$ STATED EXPLICITLY
• ² ×	$k\cos a = 5, k\sin a = 3$ STATED EXPLICITLY
• ³ ✓	$k = \sqrt{34}$
• ⁴ ✓	$a = 31$
• ⁵ ✓	$\sqrt{34} \cos(x - 31)^\circ = 4$
• ⁶ ✓	$x - 31 = \text{any one of } 46.7, 313.3$
• ⁷ ×	$x = 77.7^\circ$ (this mark not awarded as working eased) so award 5 marks(5 ticks)

3	Early rounding
• ¹ ✓	$k\cos x \cos a + k\sin x \sin a$ STATED EX.
• ² ✓	$k\cos a = 3, k\sin a = 5$ STATED EX.
• ³ ✓	$k = 5.8$
• ⁴ ✓	$a = 59$
• ⁵ ✓	$6\cos(x - 59)^\circ = 4$
• ⁶ ✓	$x - 59 = \text{any one of } -48.2, 48.2, 311.8$
• ⁷ ✓	$x = 10.8^\circ$ so award 7 marks(7 ticks)

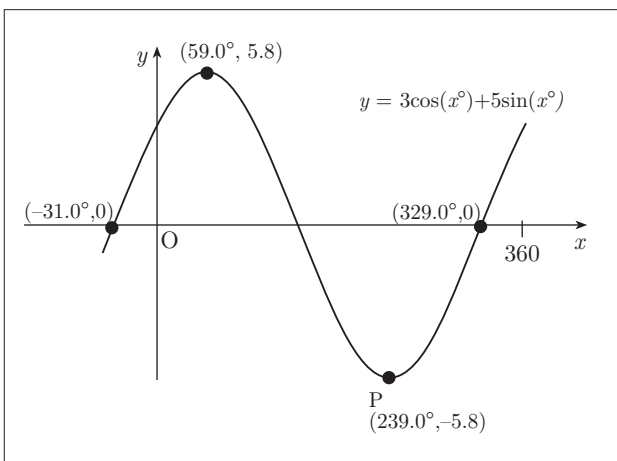

Alternative Method 2	via a Graphics Calculator
• ¹	annotated on diagram max at $(59.0, 5.8)$ and min at $(239.0, -5.8)$
• ²	annotated on diagram $(-31.0, 0)$ or $(149.0, 0)$ or $(329.0, 0)$
• ³	"from the amplitude $k = 5.8$ "
• ⁴	"from the shift $a = 59.0$ "
	4 marks
• ⁵	communication : eg solution will be where $y = 4$ meets the graph
• ⁶	annotated on diagram the line with equation $y = 4$
• ⁷	intersection gives $x = 12.3$
	3 marks

7 The graph of the cubic function $y = f(x)$ is shown in the diagram. There are turning points at $(1, 1)$ and $(3, 5)$.
Sketch the graph of $y = f'(x)$.

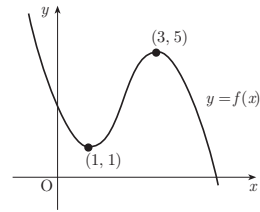

3

Qu.	part	marks	Grade	Syllabus Code	Calculator class	Source
7		3	B	1.3.13	CN	04/87

The Primary Method m/s is based on the following generic m/s. THIS GENERIC M/S MAY BE USED AS AN EQUIVALENCE GUIDE BUT ONLY WHERE A CANDIDATE DOES NOT USE THE PRIMARY METHOD OR ANY ALTERNATIVE METHOD SHOWN IN DETAIL IN THE MARKING SCHEME.

- ¹ ic : interpret stationary points
- ² ic : interpret between roots
- ³ ic : know $f'(\text{cubic}) = \text{parabola}$

Primary Method : Give 1 mark for each •

a sketch with the following details

- ¹ *only two intercepts on the x - axis at 1 and 3*
- ² *function is + ve between the roots and - ve outwith*
- ³ *a parabola (symmetrical about midpoint of x - intercepts), stated or implied by the accuracy of the diagram*

3 marks

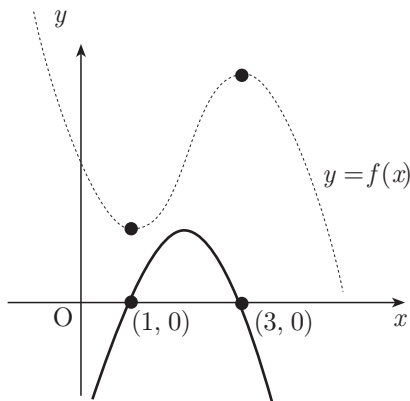

Note

- 1 The evidence for •¹ may be on a diagram or in a table or in words
- 2 For •³, with the intercepts unknown, they must lie on the positive branch of the x-axis
- 3 For a parabola passing through $(1, 1)$ and $(3, 5)$ award **ONLY 1 MARK**.

8 The circle with centre A has equation $x^2 + y^2 - 12x - 2y + 32 = 0$. The line PT is a tangent to this circle at the point P(5, -1).

(a) Show that the equation of this tangent is $x + 2y = 3$.

The circle with centre B has equation $x^2 + y^2 + 10x + 2y + 6 = 0$.

(b) Show that PT is also a tangent to this circle.

(c) Q is the point of contact. Find the length of PQ.

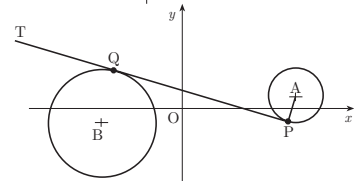
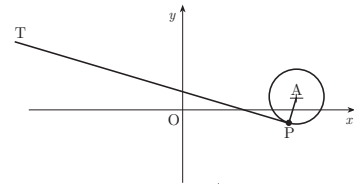

4

5

2

Qu.	part	marks	Grade	Syllabus Code	Calculator class	Source
8	a	4	C	2.4.2, 2.4.4	CN	04/113
	b	5	C	2.1.8		
	c	2	C	1.1.1		

The Primary Method m/s is based on the following generic m/s. THIS GENERIC M/S MAY BE USED AS AN EQUIVALENCE GUIDE BUT ONLY WHERE A CANDIDATE DOES NOT USE THE PRIMARY METHOD OR ANY ALTERNATIVE METHOD SHOWN IN DETAIL IN THE MARKING SCHEME.

- ¹ ic : interpret circle equation
- ² ic : find gradient
- ³ ss : know/find perpendicular gradient
- ⁴ pd : complete proof
- ⁵ pd : start solving process
- ⁶ ss : know/substitute
- ⁷ pd : arrange in standard form
- ⁸ ss : know how to justify tangency
- ⁹ ic : complete proof
- ¹⁰ ic : interpret solution from (b)
- ¹¹ pd : process distance formula

Notes

- 1 •³ is **ONLY AVAILABLE** if •² has been awarded.
- 2 •⁴ is only available if an attempt has been made to find a perpendicular gradient
- 3 completion at •⁴ :
the minimum acceptable would be

$$y + 1 = -\frac{1}{2}(x - 5)$$

$$2y + 2 = -x + 5$$

$$2y + x = 3$$

Primary Method : Give 1 mark for each •

- ¹ A(6,1)
- ² $m_{AP} = 2$ *STATED EXPLICITLY*
- ³ $m_{PQ} = -\frac{1}{2}$
- ⁴ $y + 1 = -\frac{1}{2}(x - 5)$ and complete 4 marks
- ⁵ $x = 3 - 2y$
- ⁶ $(3 - 2y)^2 + y^2 + 10(3 - 2y) + 2y + 6 = 0$
- ⁷ $5y^2 - 30y + 45 = 0$
- ⁸ solve and get double root \Rightarrow tangent
- ⁹ $5(y - 3)^2 = 0$ 5 marks
- ¹⁰ Q = (-3,3)
- ¹¹ $PQ = \sqrt{80}$ 2 marks

1 Alternative method for •1 to •4

- ¹ $(3 - 2y)^2 + y^2 - 12(3 - 2y) - 2y + 32 = 0$
- ² $5(y + 1)^2 = 0$
- ³ double root \Rightarrow tangent
- ⁴ $x = 3 - 2y = 3 - 2 \times (-1) = 5$ 4 marks

8 The circle with centre A has equation $x^2 + y^2 - 12x - 2y + 32 = 0$. The line PT is a tangent to this circle at the point P(5, -1).

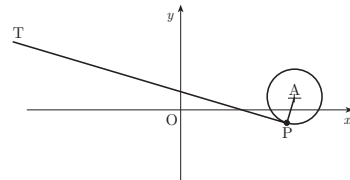

(a) Show that the equation of this tangent is $x + 2y = 3$.

The circle with centre B has equation $x^2 + y^2 + 10x + 2y + 6 = 0$.

(b) Show that PT is also a tangent to this circle.

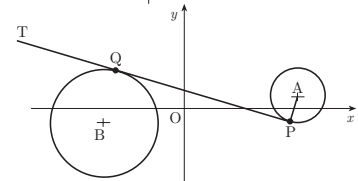

(c) Q is the point of contact. Find the length of PQ.

4
5
2

Notes cont

4 An “= 0” must appear at either the •⁶ or •⁷ stage. Failure to appear will forfeit one of these marks.

5 Evidence for (b) may appear in the working for (c)

1	Alternative for •8 and •9
• ⁸	<i>use discriminant, and get zero ⇒ tangent</i>
• ⁹	$b^2 - 4ac = (-30)^2 - 4.5.45 = 0$

2	Alternative for (c) (•10 and •11)
• ⁸	$BP = 10 \text{ units}, BQ = \text{radius} = \sqrt{20} \text{ units}$
• ⁹	<i>by Pythagoras</i> $PQ = \sqrt{80}$

3	Alternative Method for (b) (•5 to •9)
• ⁵	$y = \frac{1}{2}(3 - x)$
• ⁶	$(x)^2 + (\frac{1}{2}(3 - x))^2 + 10(x) + 2(\frac{1}{2}(3 - x)) + 6 = 0$
• ⁷	$5x^2 + 30x + 45 = 0$
• ⁸	$5(x + 3)^2 = 0$
• ⁹	<i>double root ⇒ tangency</i> <i>or</i> $b^2 - 4ac = 900 - 4.5.45 ⇒ \text{tangency}$
5 marks	

4	Alternative Method for (b) (•5 to •9)
• ⁵	<i>centre</i> $B = (-5, -1)$
• ⁶	<i>diam</i> : $y + 1 = 2(x + 5)$
• ⁷	$2x + 9 = \frac{3 - x}{2}$
• ⁸	$Q = (-3, 3)$
• ⁹	<i>check</i> : $9 + 9 - 30 + 6 + 6 = 0$
5 marks	

5	Common error for (b)
• ⁵	\times $x = 2y - 3$
• ⁶	$\sqrt{(2y - 3)^2 + y^2 + 10(2y - 3) + 2y + 6 = 0}$
• ⁷	$\sqrt{5y^2 + 10y - 15 = 0}$
• ⁸	$\sqrt{5(y + 3)(y - 1) = 0}$
• ⁹	$\sqrt{\text{intersects in two pts } (y=1 \text{ and } y=-3) ⇒ \text{not a tgt}}$
4 marks awarded	

9 An open cuboid measures internally x units by $2x$ units by h units and has an inner surface area of 12 units^2 .

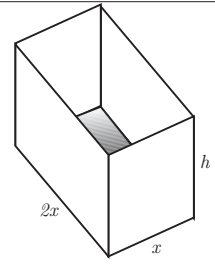

(a) Show that the volume, $V \text{ units}^3$, of the cuboid is given by

$$V(x) = \frac{2}{3}x(6 - x^2).$$

(b) Find the exact value of x for which this volume is a maximum.

3
5

Qu.	part	marks	Grade	Syllabus Code	Calculator class	Source
9	a	3	AB	1.3.15	CN	04/n
	b	5	C	1.3.15		

The Primary Method m/s is based on the following generic m/s. THIS GENERIC M/S MAY BE USED AS AN EQUIVALENCE GUIDE BUT ONLY WHERE A CANDIDATE DOES NOT USE THE PRIMARY METHOD OR ANY ALTERNATIVE METHOD SHOWN IN DETAIL IN THE MARKING SCHEME.

- ¹ ss : use area facts
- ² ss : use volume facts
- ³ ic : complete proof
- ⁴ pd : arrange in standard form
- ⁵ pd : differentiate
- ⁶ ss : set derivative to zero
- ⁷ pd : process
- ⁸ ic : justification

Primary Method : Give 1 mark for each •

- ¹ $A = 2x^2 + 2xh + 4xh = 12$
- ² $V = 2x \times x \times h$
- ³ $V = 2x \times \frac{12-2x^2}{6} = \& \text{ complete}$

3 marks

- ⁴ $V = 4x - \frac{2}{3}x^3$
- ⁵ $\frac{dV}{dx} = 4 - 2x^2$
- ⁶ $\frac{dV}{dx} = 0$ STATED EXPLICITLY
- ⁷ $x = \sqrt{2}$
- ⁸

x	$< \sqrt{2}$	$\sqrt{2}$	$> \sqrt{2}$
$\frac{dV}{dx}$	$+ve$	0	$-ve$
tgt	$/$	$-$	\backslash

max

5 marks

Alternative for •1, •2 and •3

- ¹ $2x^2 + 2xh + 4xh = 12$
- ² $h = \frac{12-2x^2}{6x}$
- ³ $V = 2x \times x \times \frac{12-2x^2}{6x} = \& \text{ complete}$

3 marks

Notes

- 1 Do not penalise the non-appearance of $-\sqrt{2}$ at the •⁷ stage.
- 2 $\frac{d^2V}{dx^2} = -4x < 0 \Rightarrow$ maximum may be accepted for •⁸.

- 10 The amount A_t micrograms of a certain radioactive substance remaining after t years decreases according to the formula $A_t = A_0 e^{-0.002t}$, where A_0 is the amount present initially.
- (a) If 600 micrograms are left after 1000 years, how many micrograms were present initially? **3**
- (b) The half-life of a substance is the time taken for the amount to decrease to half of its initial amount. What is the half-life of this substance? **4**

Qu.	part	marks	Grade	Syllabus Code	Calculator class	Source
10	a	3	C	3.3.4	CR	04/121
	b	4	AB	3.3.4		

The Primary Method m/s is based on the following generic m/s. THIS GENERIC M/S MAY BE USED AS AN EQUIVALENCE GUIDE BUT ONLY WHERE A CANDIDATE DOES NOT USE THE PRIMARY METHOD OR ANY ALTERNATIVE METHOD SHOWN IN DETAIL IN THE MARKING SCHEME.

- ¹ ss : substitute
- ² pd : change the subject
- ³ pd : process exponential power
- ⁴ ic : interpret half life
- ⁵ pd : process
- ⁶ ss : switch to logarithmic form
- ⁷ pd : solve logarithmic equation

Primary Method : Give 1 mark for each •

•¹ $600 = A_0 e^{-0.002 \times 1000}$

•² $A_0 = \frac{600}{e^{-0.002 \times 1000}}$

•³ 4433

3 marks

•⁴ $\frac{1}{2} A_0 = A_0 e^{-0.002t}$

•⁵ $0.5 = e^{-0.002t}$

•⁶ $-0.002t = \ln 0.5$

•⁷ $t = 347$ years

4 marks

1 Alternative method for (a)

•¹ $600 = A_0 e^{-0.002 \times 1000}$

•² $\ln A_0 = \ln 600 - \ln e^{-0.002 \times 1000}$

•³ $A_0 = 4433$

3 marks

Notes

- 1 Accept any correct answer which rounds to 4430.
For any other answer, rounding must be indicated.
- 2 A trial and improvement approach :
For $600 = A_0 e^{-2}$ award •¹
For eg $4000e^{-2} = 541$
 $4500e^{-2} = 609$
leading to an answer which rounds to 4430, award •³
- 3 At •⁴, A_0 may be replaced by any real number
- 4 For (b) an answer obtained by trial and improvement which rounds to 346 or 347 may be awarded 1 mark.

11 An architectural feature of a building is a wall with arched windows. The curved edge of each window is parabolic. The second diagram shows one such window. The shaded part represents the glass. The top edge of the window is part of the parabola with equation $y = 2x - \frac{1}{2}x^2$. Find the area in square metres of the glass in one window.

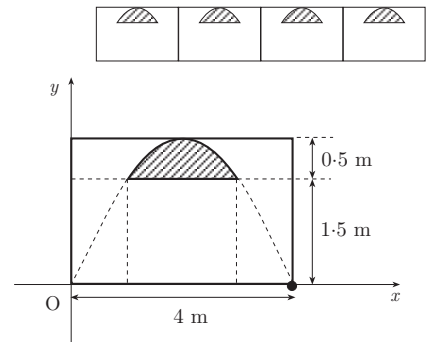

8

Qu.	part	marks	Grade	Syllabus Code	Calculator class	Source
11		8	A	2.1.0, 2.1.9	CN	04/110

The Primary Method m/s is based on the following generic m/s. THIS GENERIC M/S MAY BE USED AS AN EQUIVALENCE GUIDE BUT ONLY WHERE A CANDIDATE DOES NOT USE THE PRIMARY METHOD OR ANY ALTERNATIVE METHOD SHOWN IN DETAIL IN THE MARKING SCHEME.

- ¹ ss : find intersections
- ² pd : process quadratic to solution
- ³ ss : decide on appropriate areas
- ⁴ ss : know to integrate
- ⁵ ic : state limits
- ⁶ pd : integrate
- ⁷ pd : evaluate using limits
- ⁸ pd : evaluate area

Primary Method : Give 1 mark for each •

- ¹ $2x - \frac{1}{2}x^2 = 1.5$
- ² $x = 1, x = 3$
- ³ "split area up" *stated or implied by* •⁴
- ⁴ $\int (2x - \frac{1}{2}x^2 - \frac{3}{2}) dx$
- ⁵ $\int_1^3 \dots dx$
- ⁶ $[x^2 - \frac{1}{6}x^3 - \frac{3}{2}x]_1^3$
- ⁷ $(3^2 - \frac{1}{6} \cdot 3^3 - \frac{3}{2} \cdot 3) - (1^2 - \frac{1}{6} \cdot 1^3 - \frac{3}{2} \cdot 1)$
- ⁸ $\frac{2}{3}$

8 marks

Notes

- 1 The first two marks may be obtained as follows:
 Guess $x = 1$ and check that $y = 1.5$, award •¹
 Guess $x = 3$ and check that $y = 1.5$, award •²
- 2 In the Primary method, •³ is clearly not available for subtracting the wrong way round.
 •⁸ will also be lost for statements such as
 $-\frac{2}{3} = \frac{2}{3}$
 $-\frac{2}{3}$ so ignore the negative
 $-\frac{2}{3} = \frac{2}{3}$ squ units
 •⁸ can still be gained for statements such as
 $\dots - \frac{2}{3}$ and so the area = $\frac{2}{3}$

1 Alternative Method

- ¹ $2x - \frac{1}{2}x^2 = 1.5$
- ² $x = 1, x = 3$
- ³ $\int (2x - \frac{1}{2}x^2) dx$
- ⁴ choose limits, a and b : $0 \leq a \leq b \leq 4$
- ⁵ $[x^2 - \frac{1}{6}x^3]$
- ⁶ evaluate $[x^2 - \frac{1}{6}x^3]_a^b$ for chosen values of a and b
- ⁷ state areas to be added/subtracted *st / imp by* •⁸
- ⁸ $\frac{2}{3}$

8 marks

S1 A die has three red faces, two blue faces and one yellow face. An experiment consists of noting the uppermost colour after a roll of the die.

Random Numbers

2 7 9 8 9 6 4 7 2 8 1 0 7 4 4 0 8 3 9 6 5 6 2 4 2
 9 0 9 8 5 2 8 8 6 8 9 9 4 3 1 5 0 9 9 5 2 0 5 0 7

- (a) Use the given random numbers to simulate 18 trials of the experiment. Explain your strategy. **2**
 (b) How closely do the results of your simulation agree with the theoretical probability of obtaining blue? **2**

replacing qu.2

Qu.	part	marks	Grade	Syllabus Code	Calculator class	Source
S1	a	2	C	4.2	CR	04/124
	b	2	C	4.2		

The Primary Method m/s is based on the following generic m/s. THIS GENERIC M/S MAY BE USED AS AN EQUIVALENCE GUIDE BUT ONLY WHERE A CANDIDATE DOES NOT USE THE PRIMARY METHOD OR ANY ALTERNATIVE METHOD SHOWN IN DETAIL IN THE MARKING SCHEME.

- ¹ ic : define simulation
- ² pd : process simulation
- ³ pd : find probability
- ⁴ ic : comment

Primary Method : Give 1 mark for each •
<ul style="list-style-type: none"> •¹ define simulation •² results of simulation •³ $P(\text{blue}_{\text{theoretical}}) = \frac{1}{3}$ •³ cf simulation $P(\text{blue}_{\text{experimental}})$ with $\frac{1}{3}$ <p style="text-align: right;"><i>4 marks</i></p>

S2 As part of a study on intensive exercise, a sports scientist recorded the peak heart rates of a random selection of sixteen volunteers of different ages who took regular exercise. The linear regression equation was calculated for the data shown in the scatter diagram and found to be $y = 209 - 0.727x$.

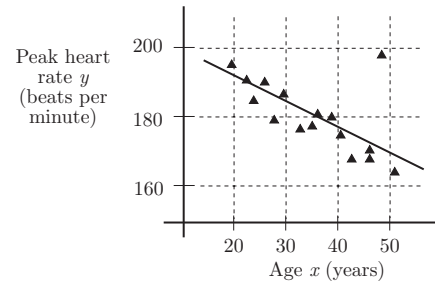

However after considering the scatter diagram for the data, it was realised that one piece of data had been misrecorded and this volunteer's data was ignored.

- (a) State the approximate age of the volunteer whose data was ignored. 1
- (b) Calculate the new regression equation using the values $\Sigma x = 509, \Sigma x^2 = 18\,477, \Sigma y = 2738, \Sigma y^2 = 501\,192, \Sigma xy = 91\,694$. 6
- (c) Comment on the difference this makes to the prediction for the average peak heart rate of a 45 year old volunteer. 2

replacing qu.6

Qu.	part	marks	Grade	Syllabus Code	Calculator class	Source
S2	a	1	B	4.4.2	CR	04/131
	b	6	B	4.4.2		
	c	2	A	4.4.2		

The Primary Method m/s is based on the following generic m/s. THIS GENERIC M/S MAY BE USED AS AN EQUIVALENCE GUIDE BUT ONLY WHERE A CANDIDATE DOES NOT USE THE PRIMARY METHOD OR ANY ALTERNATIVE METHOD SHOWN IN DETAIL IN THE MARKING SCHEME.

- ¹ ic : estimate from graph
- ² ic : state n
- ³ pd : process
- ⁴ pd : process
- ⁵ pd : determine regression coefficients
- ⁶ pd : determine regression coefficients
- ⁷ ic: state regression equation
- ⁸ pd : use regression equation
- ⁹ ic : interpret results

Primary Method : Give 1 mark for each •

- ¹ 48 1 mark
- ² $n = 15$
- ³ $S_{xx} = 1204.93$
- ⁴ $S_{xy} = -1215.47$
- ⁵ $a = 217$
- ⁶ $b = -1.01$
- ⁷ $y = 217 - 1.01x$ 6 marks
- ⁸ $est_{old} = 176, est_{new} = 172$
- ⁹ removing outlier improves estimate 2 marks

S3 The selection procedure for a Police force consists of 3 independent tests, Intelligence(I), Fitness (F) and Communication(C). The outcome of each test is an independent event and is either pass or fail. A candidate must pass all three tests to enter training. It has been established that the probability of failing each test is as follows:

Test	I	F	C
P(failing)	0.2	0.6	0.3

- (a) Calculate the probability that a candidate will be selected for training. 2
- (b) Five candidates are being tested for selection. Find the probability that
 - (i) all five candidates will be accepted
 - (ii) all five candidates will be rejected. 3

replacing qu.10

Qu.	part	marks	Grade	Syllabus Code	Calculator class	Source
S3	a	2	B	4.2.7	CN	04/126
	b	32	B	4.2.10		

The Primary Method m/s is based on the following generic m/s. THIS GENERIC M/S MAY BE USED AS AN EQUIVALENCE GUIDE BUT ONLY WHERE A CANDIDATE DOES NOT USE THE PRIMARY METHOD OR ANY ALTERNATIVE METHOD SHOWN IN DETAIL IN THE MARKING SCHEME.

- ¹ ss : use approp. strategy P(Pass) or 1 – P(fail)
- ² pd : process
- ³ pd : process all pass
- ⁴ pd : process one fail
- ⁵ pd : process all fail

Primary Method : Give 1 mark for each •	
<ul style="list-style-type: none"> •¹ P(selected) = $0.8 \times 0.4 \times 0.7$ •² 0.224 or $\frac{28}{125}$ 	2 marks
<ul style="list-style-type: none"> •³ $0.224^5 = 0.000564$ •⁴ P(1 not selected) = 0.776 •⁵ $0.776^5 = 0.281$ 	3 marks

S4 Show that the diagram represents a probability density function for a continuous random variable X .

replacing *qu.10*

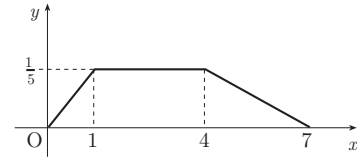

3

Qu.	part	marks	Grade	Syllabus Code	Calculator class	Source
S4		3	A	4.3.4	CN	04/129

The Primary Method m/s is based on the following generic m/s.
THIS GENERIC M/S MAY BE USED AS AN EQUIVALENCE GUIDE
BUT ONLY WHERE A CANDIDATE DOES NOT USE THE PRIMARY
METHOD OR ANY ALTERNATIVE METHOD SHOWN IN DETAIL IN
THE MARKING SCHEME.

- ¹ ic : state requirement for pdf
- ² ic : state requirement for pdf
- ³ pd : complete proof

Primary Method : Give 1 mark for each •

- ¹ function above $x -$ axis
- ² total area must be 1
- ³ $\frac{1}{2} \times 1 \times \frac{1}{5} + 3 \times \frac{1}{5} + \frac{1}{2} \times 3 \times \frac{1}{5}$
 $= \frac{1}{10} + \frac{6}{10} + \frac{3}{10} = 1$

3 marks