

FOR OFFICIAL USE



National
Qualifications
2021 ASSESSMENT RESOURCE

Mark

X840/76/01

**Human Biology
Paper 2**

Duration — 2 hours 20 minutes



Fill in these boxes and read what is printed below.

Full name of centre

Town

Forename(s)

Surname

Number of seat

Date of birth

Day

Month

Year

Scottish candidate number

Total marks — 95

Attempt ALL questions.

You may use a calculator

Question 14 contains a choice.

Write your answers clearly in the spaces provided in this booklet. Additional space for answers and rough work is provided at the end of this booklet. If you use this space you must clearly identify the question number you are attempting. Any rough work must be written in this booklet. Score through your rough work when you have written your final copy.

Use **blue** or **black** ink.

Before leaving the examination room you must give this booklet to the Invigilator; if you do not, you may lose all the marks for this paper.



[BLANK PAGE]

DO NOT WRITE ON THIS PAGE



* X 8 4 0 7 6 0 1 0 2 *

Total marks — 95
 Attempt ALL questions
 Question 14 contains a choice

1. The diagram shows a range of cell types produced by blood stem cells.

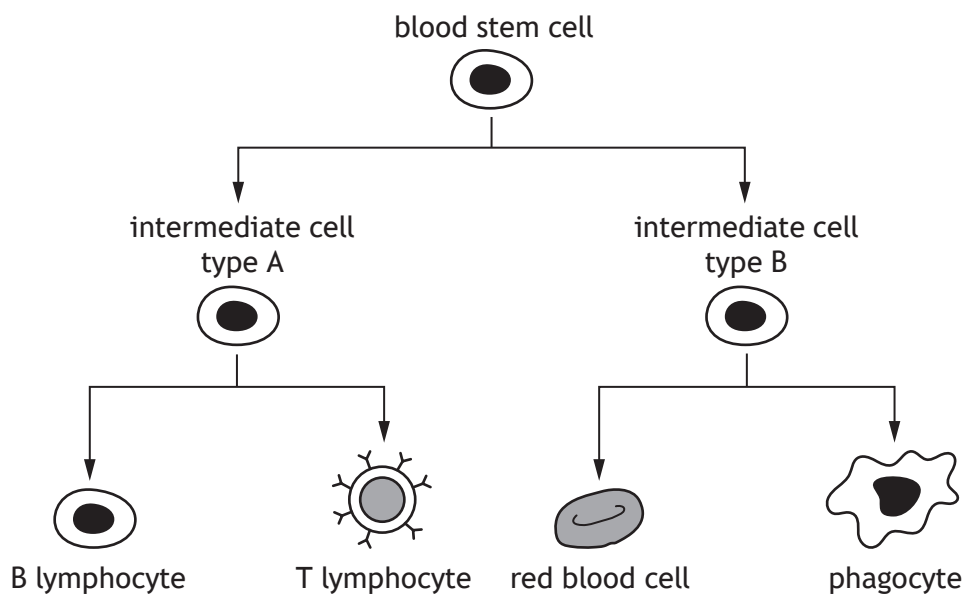

(a) State the location of blood stem cells in the body. 1

(b) Use information in the diagram to explain why blood stem cells are described as tissue stem cells. 1

(c) Describe one therapeutic use and one research use of stem cells. 2

Therapeutic use _____

Research use _____



2. (a) The tables show the number of deaths from some common types of cancer in males and females in Scotland in 2016.

MARKS
DO NOT
WRITE IN
THIS
MARGIN

The tables also show the percentage change in the number of deaths since 2007 due to these types of cancer.

Table 1 Males

Type of cancer	Number of deaths in 2016	Change in number of deaths since 2007 (%)
Lung	2036	-24.3
Prostate	986	-6.2
Bowel	884	-15.1
Head and neck	377	+17.1
Liver	375	+47.4
Bladder	311	-7.7
Stomach	273	-32.8
Other	3085	—
Total	8327	-12.4

Table 2 Females

Type of cancer	Number of deaths in 2016	Change in number of deaths since 2007 (%)
Lung	2033	-7.1
Breast	946	-17.2
Bowel	803	-5.8
Ovary	400	
Liver	256	+92.8
Uterus		+59.1
Bladder	166	-8.5
Other	2138	—
Total	7774	-7.5

- (i) State which type of cancer in males shows the largest percentage decrease in the number of deaths since 2007.

1



* X 8 4 0 7 6 0 1 0 4 *

2. (a) (continued)

MARKS

DO NOT
WRITE IN
THIS
MARGIN

- (ii) Calculate the number of female deaths from cancer of the uterus in 2016.

1

Space for calculation

- (iii) There were 500 deaths from cancer of the ovary in 2007.

Calculate the percentage decrease in the number of deaths due to this type of cancer since 2007.

1

Space for calculation

- (iv) **Using information from Table 1**, explain why it may **not** be correct to state that there were no male deaths from breast cancer in 2016.

1

- (v) Suggest a reason for the difference in the percentage change in the number of deaths due to lung cancer between males and females since 2007.

1

- (b) Since 2007, all people in Scotland between the ages of 50 and 74 have been offered regular screening for bowel cancer.

Suggest how this screening programme may have contributed to the percentage decrease in the number of deaths from bowel cancer between 2007 to 2016.

1

- (c) Cancer cells may divide excessively to form a tumour.

Describe how secondary tumours can then form from this tumour.

1



* X 8 4 0 7 6 0 1 0 5 *

3. (a) The diagram represents a section of DNA from a chromosome undergoing replication.

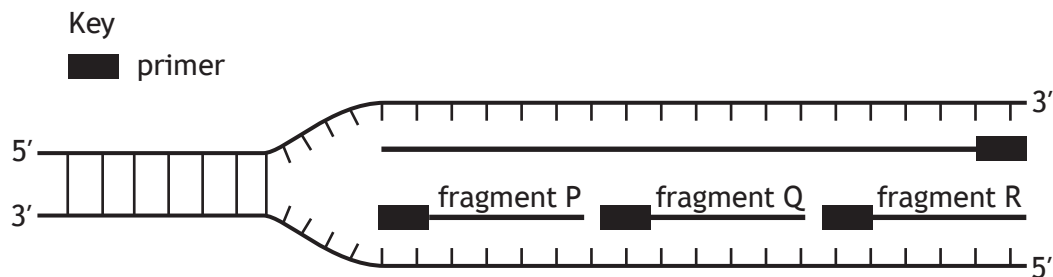

(i) Describe the role of primers in allowing DNA replication to start. 2

(ii) Fragments P, Q and R are joined together to replicate the lagging strand.
 Explain why the lagging strand is replicated in fragments. 1

(iii) Identify the first fragment produced from the lagging strand. 1

(iv) Name the enzyme that joins the fragments together. 1



3. (continued)

(b) The graph shows changes in the temperature of a reaction tube during one cycle of the polymerase chain reaction (PCR).

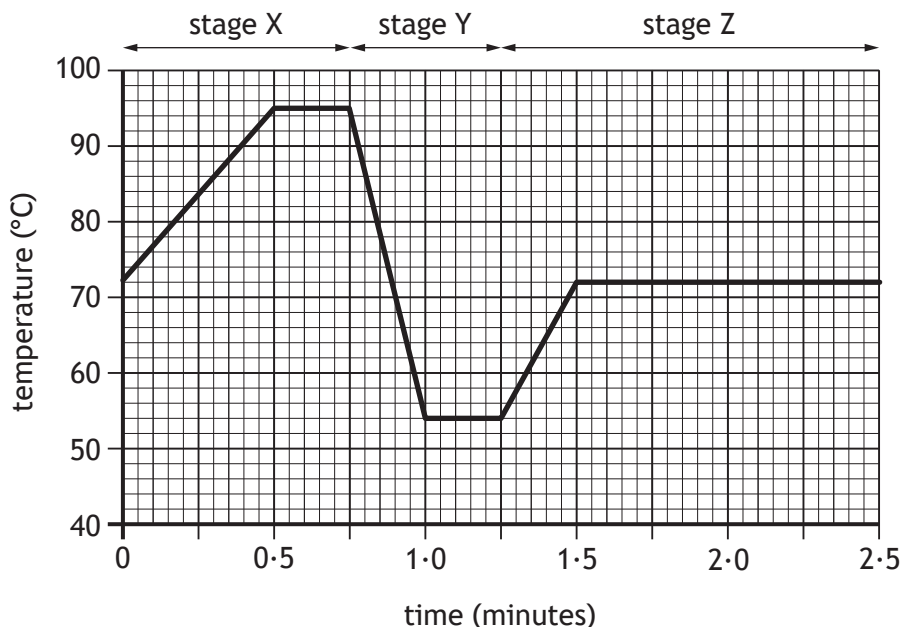

(i) Before the reaction began there were 1000 copies of a DNA fragment in the reaction tube.

Calculate the time it would take until there were at least one million copies of this DNA fragment present.

1

Space for calculation

_____ minutes

(ii) Explain why the reaction tube is heated in stage X.

1

(iii) Explain why the reaction tube is cooled in stage Y.

1



4. An investigation was carried out to show the effect of two different inhibitors on the rate of a reaction, catalysed by an enzyme.

The graph shows the results of this investigation.

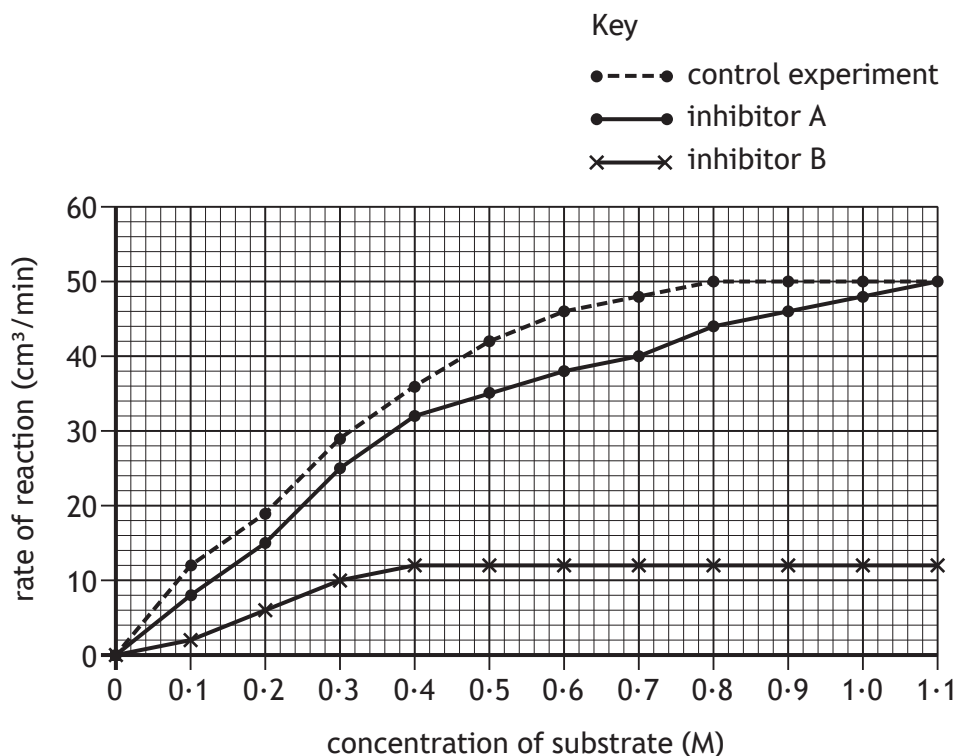

- (a) Name the substances present in the control experiment. 1

- (b) Use the information in the graph to select which inhibitor is non-competitive and give a reason for your choice. 1

Inhibitor _____

Reason _____

- (c) Calculate the decrease in the rate of reaction caused by inhibitor B at 0.7 M substrate concentration. 1

Space for calculation

_____ cm³/min



4. (continued)

(d) Predict the rate of reaction using inhibitor A at a substrate concentration of 1.2 M.

1

_____ cm³/min

(e) The diagram represents a reaction in a metabolic pathway.

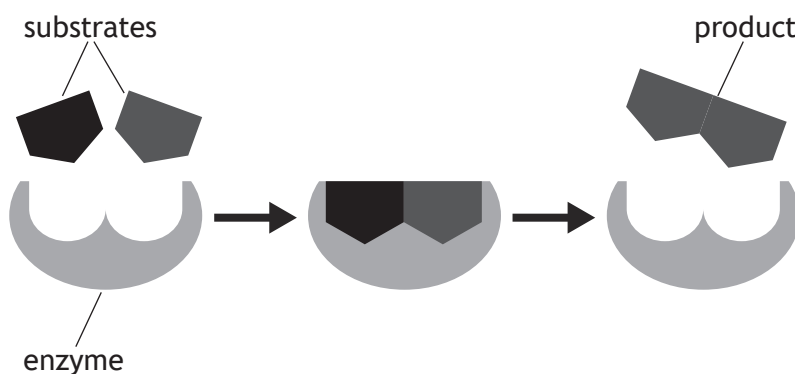

(i) Name the type of reaction shown in the diagram and give a reason for your answer.

2

Type of reaction _____

Reason _____

(ii) Describe the role of induced fit in this enzyme-catalysed reaction.

2

[Turn over



5. Proton pumps are proteins found in the membranes of cells lining the stomach.

Protons are hydrogen ions that increase acidity.

An investigation was carried out to determine the effect of a drug that acts as a proton pump inhibitor.

The inhibitor drug is usually given to people who produce too much stomach acid.

The diagrams show how the drug works.

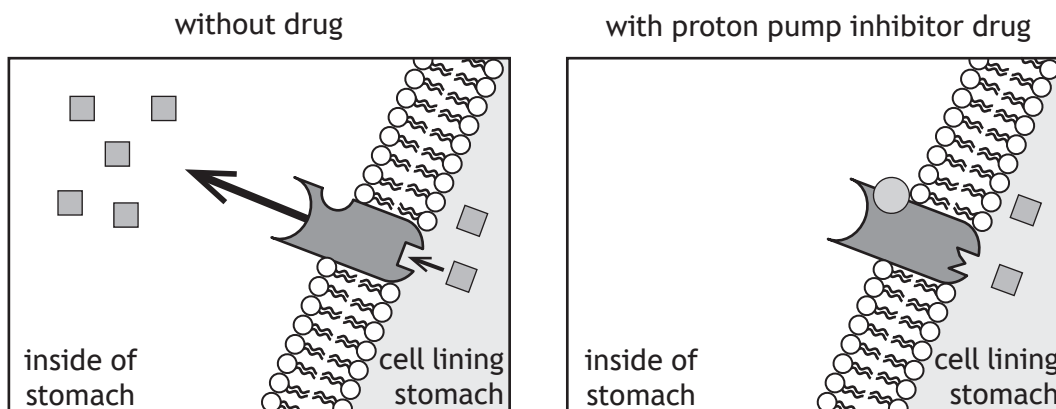

Key

■ proton (hydrogen ion)



proton pump



proton pump inhibitor drug

- (a) Use the diagrams to describe how this proton pump inhibitor drug works. 2

- (b) A large number of individuals who produced too much acid in their stomachs were divided into two groups.

Individuals in Group A consumed a tablet containing the proton pump inhibitor drug at the start of the investigation.

Individuals in Group B formed the control group.

- (i) State how the individuals would be assigned to each group in order to reduce bias. 1



* X 8 4 0 7 6 0 1 1 0 *

5. (b) (continued)

MARKS

DO NOT
WRITE IN
THIS
MARGIN

- (ii) The average acid production of each group was measured every two hours over an eight hour period and the results are shown in the graph.

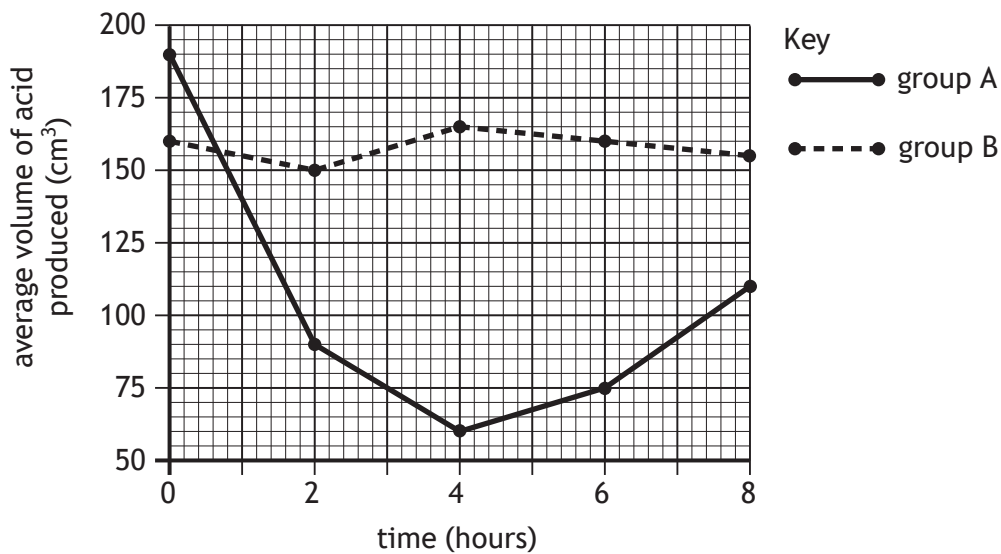

Use data from the graph to describe the changes that occurred in the acid production of group A during the investigation.

2

- (iii) A student analysed these results and concluded that the drug was most effective at four hours.

Explain why this conclusion may **not** be correct.

1

- (c) Apart from their role in making the stomach more acidic, hydrogen ions are required for ATP synthesis in the mitochondria.

Describe the role of hydrogen ions in ATP synthesis.

2



* X 8 4 0 7 6 0 1 1 1 *

6. The graph shows changes in a female's FSH and LH concentrations over 36 days.

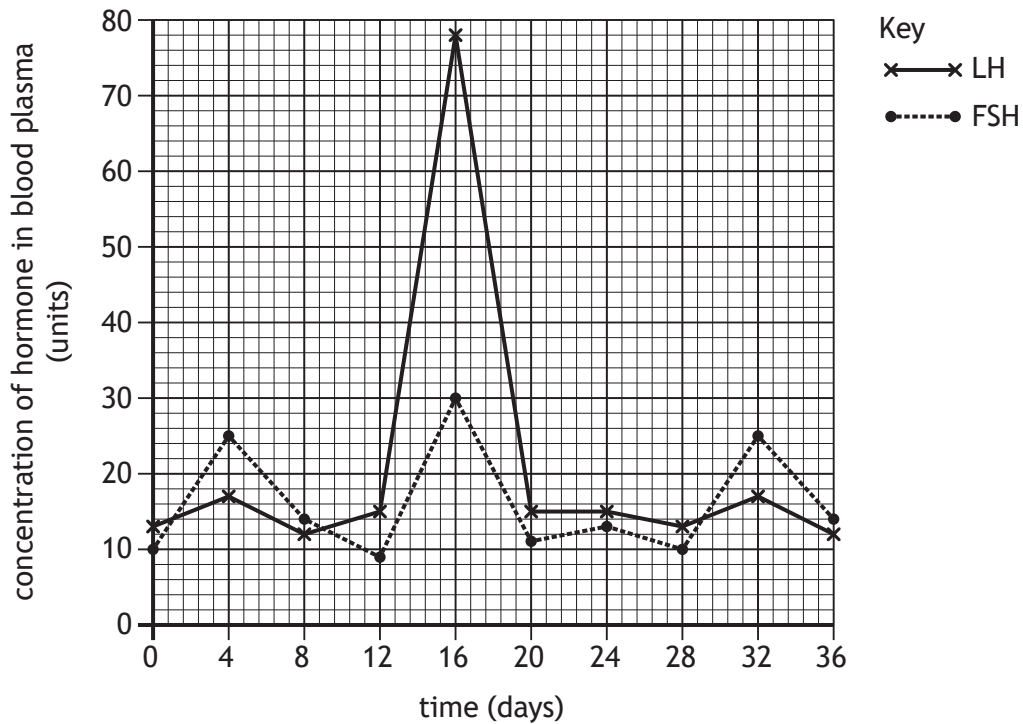

- (a) Name the part of the brain that produces the releaser hormone, which triggers FSH and LH secretion at puberty.

1

- (b) Describe **one** role of FSH in females.

1

- (c) Calculate the increase that occurs in the concentration of LH between day 12 and day 16.

1

Space for calculation

_____ units



* X 8 4 0 7 6 0 1 1 2 *

6. (continued)

(d) A surge in LH triggers ovulation.

Name the phase of the menstrual cycle that takes place after ovulation.

1

(e) Describe how a decrease in LH concentration leads to menstruation.

2

(f) Explain how the information in the graph indicates that this female has cyclical fertility.

1

(g) Explain one way that fertility drugs stimulate ovulation.

1

[Turn over



* X 8 4 0 7 6 0 1 1 3 *

7. Familial hypercholesterolaemia (FH) is a genetic disorder caused by a **dominant** allele that raises blood cholesterol concentrations.

(a) The diagram shows the family history of this condition over three generations.

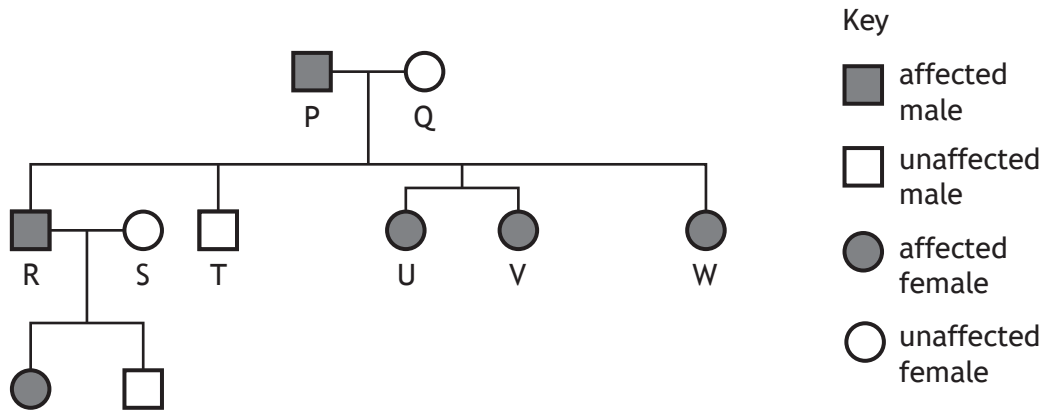

(i) FH is caused by a mutation on chromosome 19.

State the name for a chromosome that is **not** a sex chromosome.

1

(ii) Referring to individuals labelled in the diagram, describe how the inheritance pattern shown indicates that this condition cannot be caused by a sex-linked allele.

1

(iii) If daughter W had a child with a man who is heterozygous, calculate the percentage chance of the child inheriting FH.

1

Space for calculation

_____ %

(iv) State the relationship between sisters U and V.

1



* X 8 4 0 7 6 0 1 1 4 *

7. (continued)

- (b) FH results in non-functional LDL receptors.

Explain why non-functional LDL receptors can lead to an individual having high blood pressure.

2

- (c) (i) Name a type of medication used to reduce blood cholesterol concentrations.

1

- (ii) Explain the benefit of regular physical activity to individuals suffering from high blood cholesterol.

2

[Turn over



* X 8 4 0 7 6 0 1 1 5 *

8. An investigation was set up to study the effect of the intensity of exercise on cardiac output.

An individual was asked to run on a treadmill and their heart rate and stroke volume were measured.

At the start of the investigation the gradient of the treadmill was set at 0.

To increase the intensity of exercise the gradient was increased in evenly stepped stages from 0 through to 10.



Heart rate and stroke volume were measured and used to calculate the cardiac output.

- (a) (i) State **one** variable that should be kept constant during this investigation.

1

- (ii) Describe how the reliability of the results from this investigation could be increased.

1



8. (continued)

MARKS
DO NOT WRITE IN THIS MARGIN

(b) The results of this investigation are shown in the table.

Treadmill gradient	Heart rate (beats/min)	Stroke volume (cm ³)	Cardiac output (litres/min)
0	100	86	8.6
2	109	90	9.8
4	124	100	12.4
6	151	110	16.6
8	174	100	17.4
10	185		17.6

(i) Calculate the stroke volume when the treadmill gradient was set at 10.

1

Space for calculation

_____ cm³

(ii) Draw a line graph to show the effect of treadmill gradient on cardiac output.

2

(Additional graph paper, if required, can be found on page 28.)

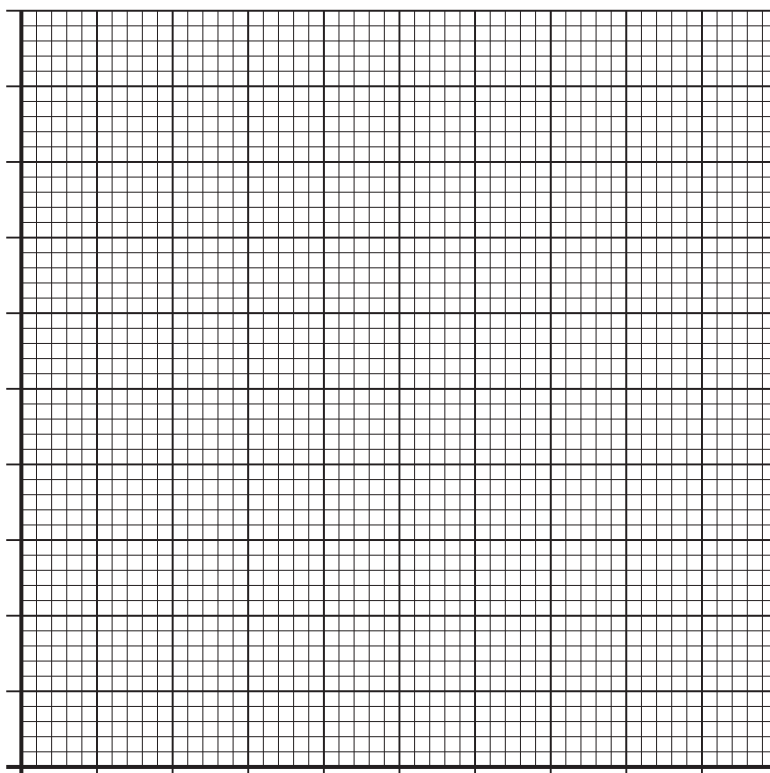

MARKS

DO NOT
WRITE IN
THIS
MARGIN

8. (b) (continued)

(iii) State a conclusion that can be drawn from the results of this investigation.

1

(c) Suggest why stroke volume was observed to decrease after treadmill gradient 6.

1



* X 8 4 0 7 6 0 1 1 8 *

9. The diagram represents a neuron from an individual who has an autoimmune disease.

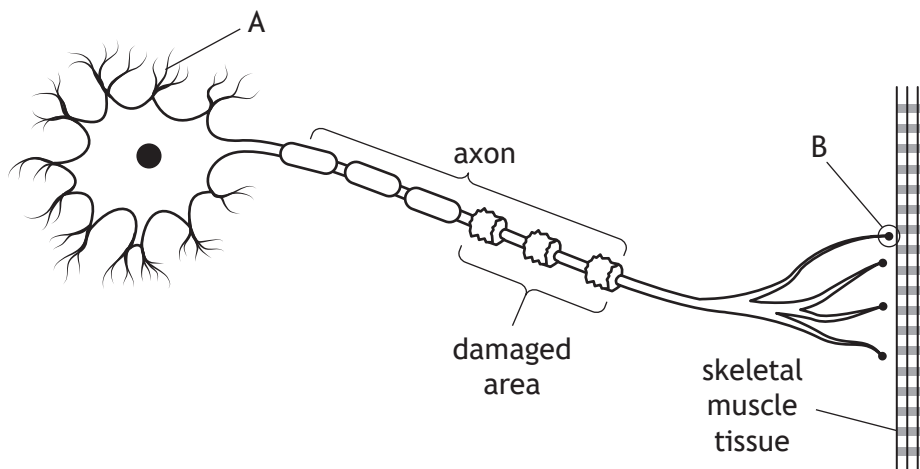

- (a) Name A and B.

2

A _____

B _____

- (b) Describe the role of the immune system in causing this autoimmune disease.

2

- (c) Explain why this individual has a loss of muscle coordination.

1

[Turn over



* X 8 4 0 7 6 0 1 1 9 *

10. The diagram shows divisions of the nervous system.

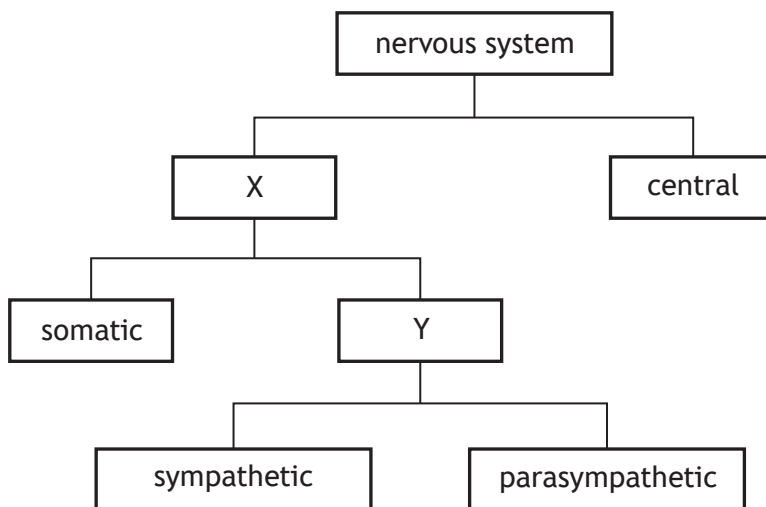

(a) Name the divisions of the nervous system labelled X and Y. 2

X _____

Y _____

(b) The somatic nervous system contains sensory neurons. Describe the function of sensory neurons. 1

(c) Describe an effect of the parasympathetic nervous system on breathing and the digestive system. 2

Breathing _____

Digestive system _____



11. (a) A biology teacher was teaching a lesson about the heart.

- (i) Name the level of memory involved when students first saw and heard information on the heart.

1

- (ii) As part of the lesson, students coloured in and labelled a diagram of the heart.

Suggest how a diagram of the heart in an exam might provide a contextual cue to this activity.

1

- (b) Describe **three** methods that help transfer information from short-term to long-term memory during learning.

3

[Turn over



* X 8 4 0 7 6 0 1 2 1 *

12. The number of excess winter deaths is calculated by subtracting the average number of deaths in autumn and spring from the number of deaths in winter.

(a) The table shows the number of deaths in Scotland in 2017/18.

Season	Number of deaths
autumn 2017	18 694
winter 2017/18	23 137
spring 2018	17 986

Calculate the number of excess winter deaths in 2017/18.

1

Space for calculation

(b) The graph shows the number of excess winter deaths in Scotland and England between 2013/14 and 2016/17.

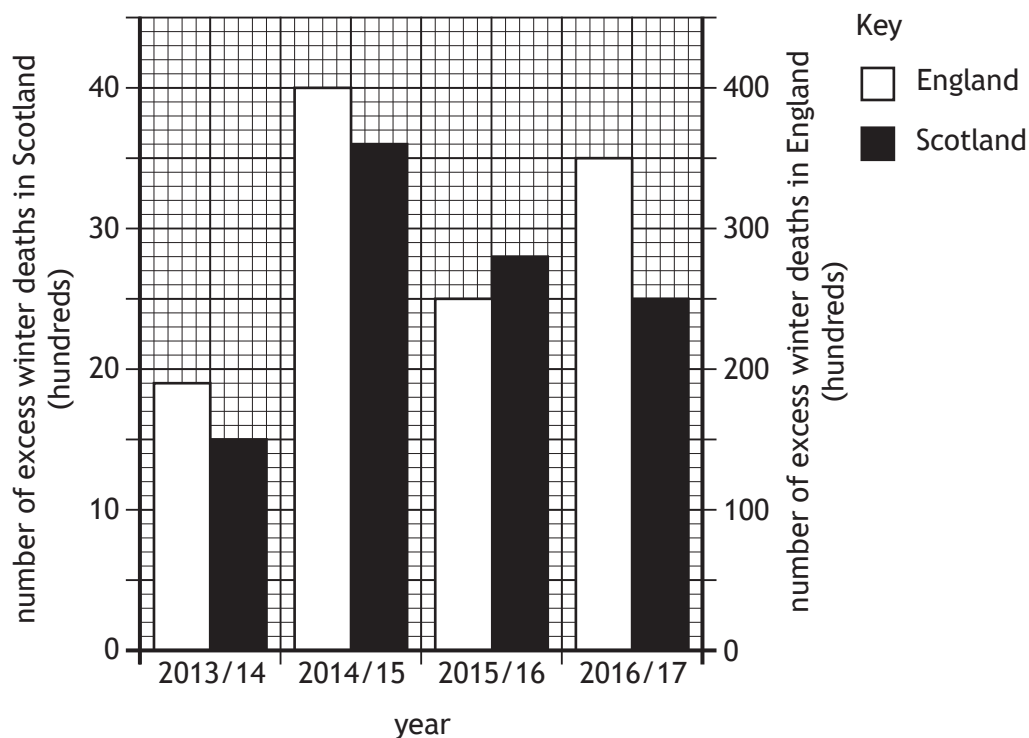

12. (b) (continued)

MARKS

DO NOT
WRITE IN
THIS
MARGIN

- (i) Describe one similarity and one difference in the trends in the number of excess winter deaths between the two countries.

2

Similarity _____

Difference _____

- (ii) Explain how the data should be expressed to allow a valid comparison of excess winter deaths in Scotland compared to England in each year.

1

- (iii) Express, as a simple whole number ratio, the number of excess winter deaths in Scotland compared to those in England in the winter of 2014/15.

1

Space for calculation

_____ : _____
Scotland England

- (c) The table shows the percentage of excess winter deaths caused by respiratory and circulatory diseases in England in the winter of 2015/16.

Diseases	Excess winter deaths (%)
circulatory	18
respiratory	39

Use information in the table and graph to calculate the number of excess winter deaths in England caused by respiratory diseases in 2015/16.

1

Space for calculation



* X 8 4 0 7 6 0 1 2 3 *

12. (continued)

- (d) The influenza virus can cause respiratory diseases.

Describe how the influenza virus can change from one winter to the next.

1

- (e) Name the type of cells that form a physical barrier in the inner lining of the respiratory system.

1



* X 8 4 0 7 6 0 1 2 4 *

13. Whooping cough is an infectious disease caused by a bacterium.
The graph shows the number of whooping cough cases in Scotland between 2012 and 2016.

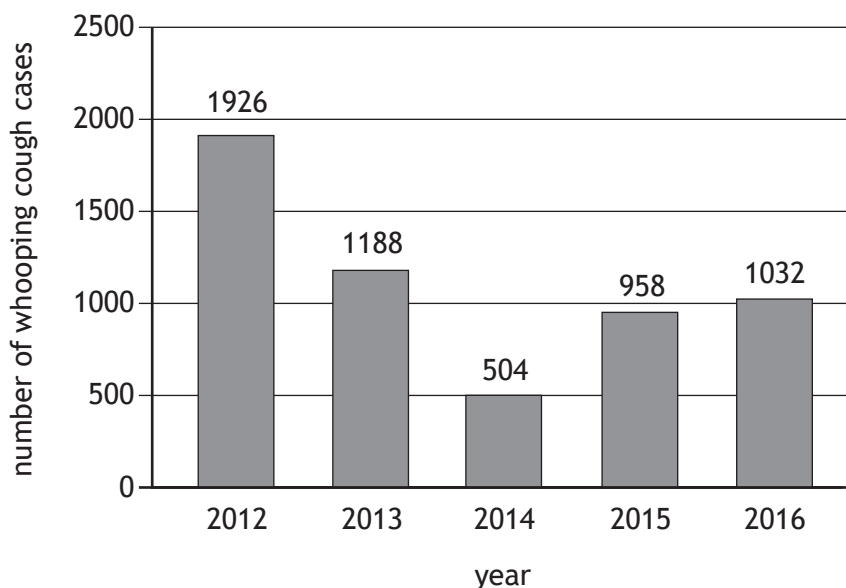

- (a) A vaccine for whooping cough was first introduced for pregnant women in Scotland in 2012.
- (i) Suggest a reason for the increase in the number of cases of whooping cough between 2014 and 2016. 1
- _____
- _____
- (ii) Calculate the percentage increase in cases from 2014 to 2016. 1
- Space for calculation*
- _____ %
- (b) Explain why vaccines do not cause disease in vaccinated individuals. 1
- _____
- _____
- (c) Name a substance that is added to a vaccine to make it more effective. 1
- _____



14. Attempt **either** A or B. Write your answer in the space below and on *page 27*.

A Discuss the use of antenatal screening and diagnostic testing to monitor the health of the developing fetus during pregnancy.

9

OR

B Discuss the structure and function of arteries, veins and capillaries in the circulatory system.

9

You may use labelled diagrams where appropriate.



* X 8 4 0 7 6 0 1 2 6 *

MARKS

DO NOT
WRITE IN
THIS
MARGIN

ADDITIONAL SPACE FOR ANSWER to question 14

[END OF QUESTION PAPER]



* X 8 4 0 7 6 0 1 2 7 *

MARKS

DO NOT
WRITE IN
THIS
MARGIN

ADDITIONAL SPACE FOR ANSWERS AND ROUGH WORK

Additional graph paper for question 8 (b) (ii)

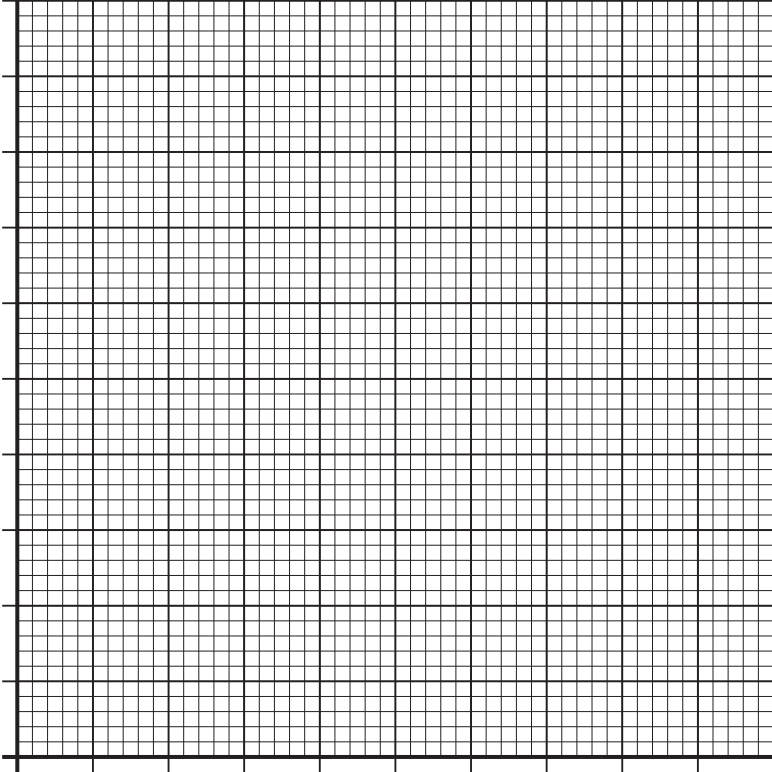

MARKS

DO NOT
WRITE IN
THIS
MARGIN

ADDITIONAL SPACE FOR ANSWERS AND ROUGH WORK



* X 8 4 0 7 6 0 1 2 9 *

MARKS

DO NOT
WRITE IN
THIS
MARGIN

ADDITIONAL SPACE FOR ANSWERS AND ROUGH WORK



* X 8 4 0 7 6 0 1 3 0 *

[BLANK PAGE]

DO NOT WRITE ON THIS PAGE



* X 8 4 0 7 6 0 1 3 1 *

[BLANK PAGE]

DO NOT WRITE ON THIS PAGE

Acknowledgement of copyright

Question 8 peart.ru/shutterstock.com



* X 8 4 0 7 6 0 1 3 2 *