



National
Qualifications
2018

X735/76/11

**Graphic Communication
Supplementary Sheets**

THURSDAY, 10 MAY

1:00 PM – 3:00 PM

Supplementary sheets for use with questions 4 (a), 5 and 6 (f)–(j).



* X 7 3 5 7 6 1 1 *

Supplementary sheet for use with question 4 (a)

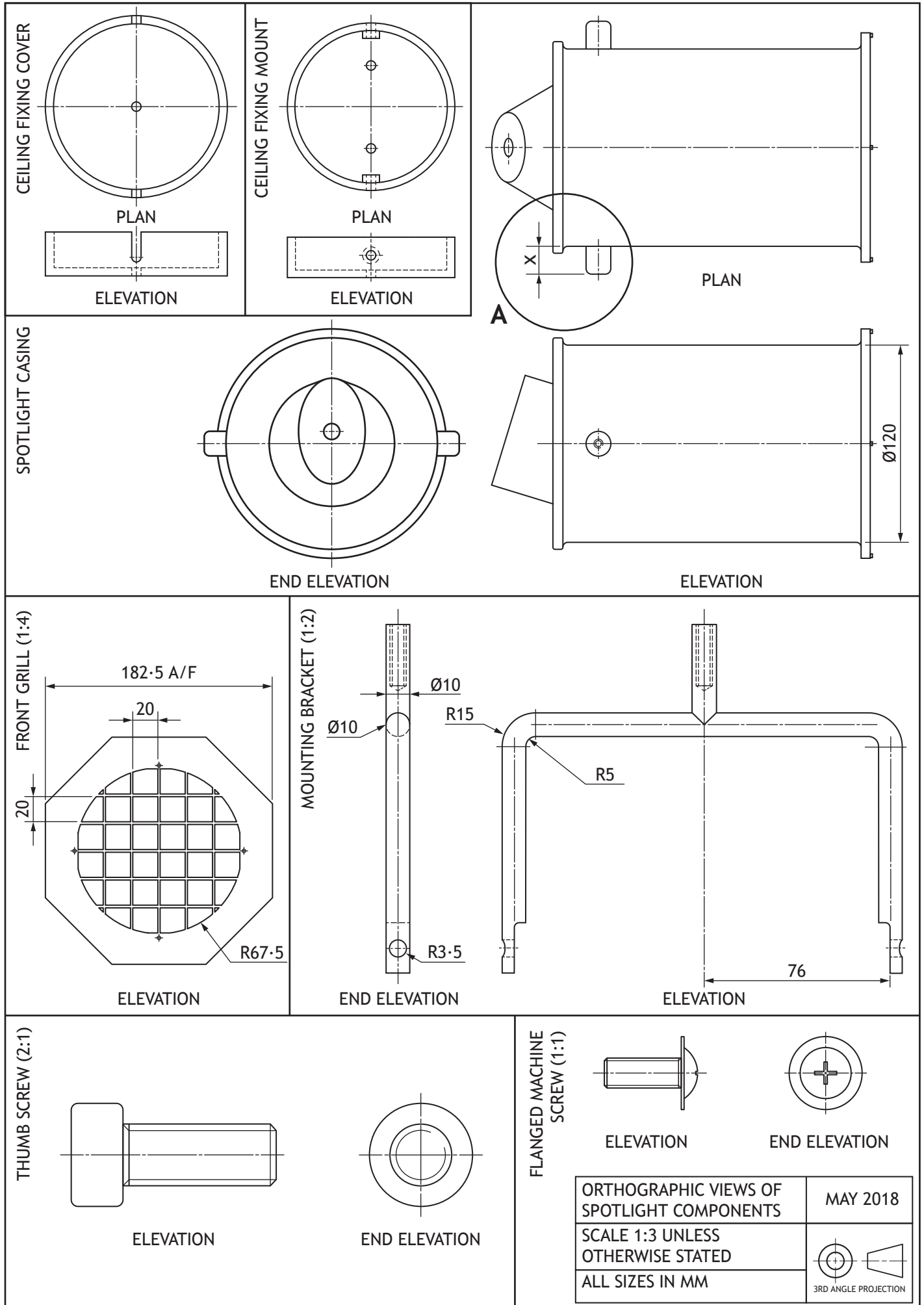

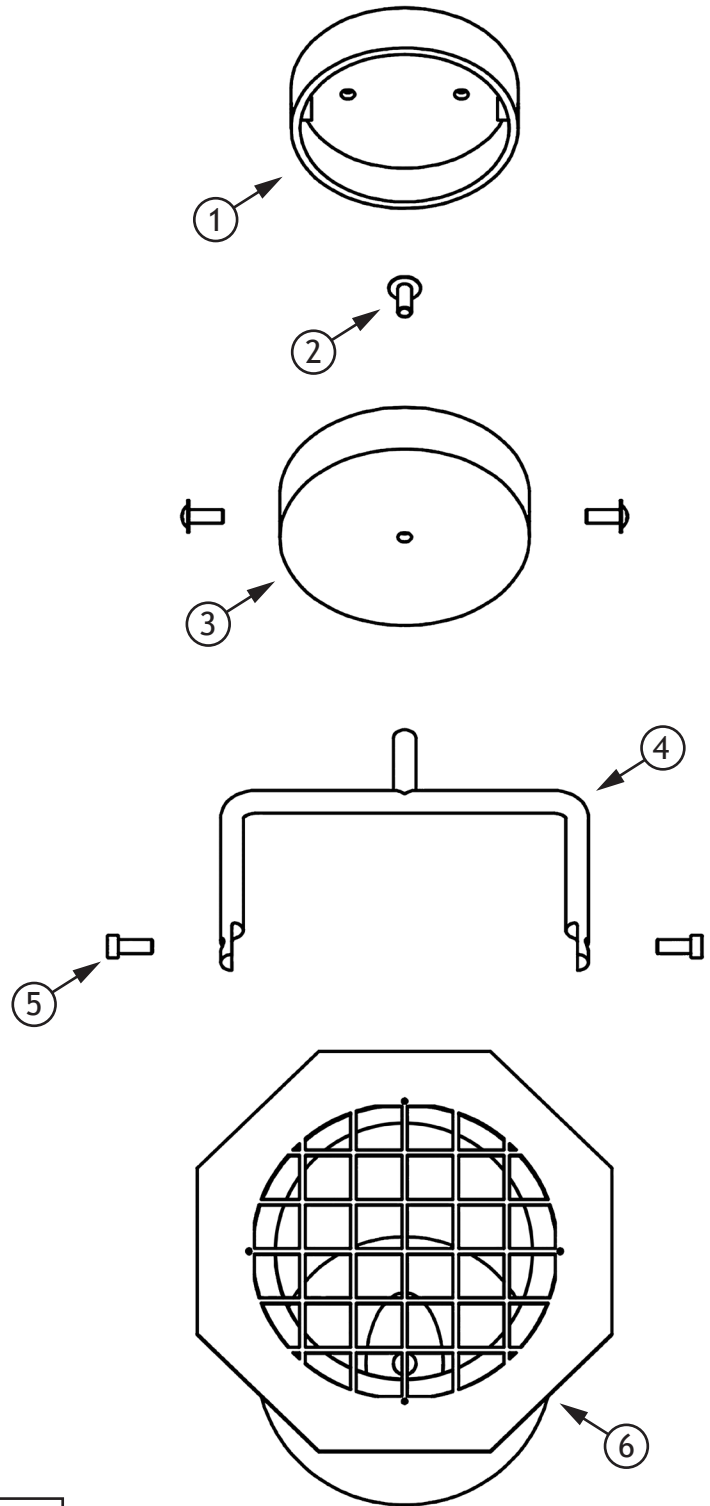

PARTS LIST		
PART NO.	PART NAME	NO. OF PARTS
1	CEILING FIXING MOUNT	1
2	FLANGED MACHINE SCREW	3
3	FIXING COVER	1
4	MOUNTING BRACKET	1
5	THUMB SCREW	2
6	SPOTLIGHT CASING AND GRILL	1

Infographic

Reducing your

Energy Bill

1. CHANGE THE WAY YOU PAY

<p>BEFORE</p> <p>Prellentesque efficitur tempus felis ac tristique. Nunc pulvinar cursus molestie. Cras enim enim, laoreet id suscipit eu, commodo volutpat ex. Vestibulum eget faucibus turpis, quis placerat dolor. Nam hendrerit sem quis purus ver fe maximus egestas. Quisque eu nibh eb re id ipsum mattis egestas eu a nibh.</p>	<p>AFTER</p> <p>Mlla lacinia molestie scelerisque. Sed placerat pellentesque erat sit amet accumsan. In hac habitasse platea dictumst. Sed ver vehicula interdum tellus, non molestie libero. Class aptent taciti sociosqu ad litora torquent per conubia nostra, per ver ser inceptos himenaeos. </p>
---	---

2. WRAP UP TO STAY WARM

<p>BEFORE</p> <p>Ptiam sit amet pretium odio, id gravida lectus. Ut felis ligula, vehicula id mauris veras ac, placerat pretium der magna. Donec interdum cursus velit, a accumsan nulla dictum sed. Aenean placerat augue sit amet porta efficitur. Suspendisse sem tellus, egestas quis iaculis et, efficitur a nulla. </p>	<p>AFTER</p> <p>Nud sed ger seur posuere velit. Suspendisse med faseuismod leo mauris, non tristique ligula fringilla eget. Nam sed vehicula dolor, mattis placerat leo. Donec vel lobortis ligula. Quisque pharetra ligula sed purus dignissim, at vehicula ante cursus. Praesent non neque enim.</p>
--	--

3. GO SOLAR AND SAVE

<p>BEFORE</p> <p>Soed sed ner masa posuere velit. Suspendisse euismod leo mauris, non tristique ligula fringilla eget. Nam sed vehicula dolor, mattis placerat leo. Donec vel lobortis ligula. Quisque pharetra ligula sed purus dignissim, at vehicula ante cursus.</p>	<p>AFTER</p> <p>Tliquam purus ver sapien, placerat aliquam der as diam pellentesque, tempus blandit per em nibh. Aenean convallis ipsum ar sa ne vel metus scelerisque vera auctor. Cras iaculis tempus tellus, id dignissim libero tincidunt a. Curabitur luctus ne ver pretium egestas. Bitasse platea dictumst. </p>
--	--

4. GET SMART ABOUT IT

<p>BEFORE</p> <p>Huis commodo faucibus enim, id convallis vera es ex auctor eget. Maecenas porttitor ea semper metus quis imperdiet. Nullam id cursus dui. Fusce non turpis maximus, egestas ante non, iaculis sapien. Quisque dictum ersa sapien ers at turpis accumsan, ut finibus elit iaculis. Proin vel viverra elit. </p>	<p>AFTER</p> <p>Sonsectetur adipiscing elit. Ut sed vulputate turpis. Ut ac vehicula nulla. Nam mattis risus eu urna tincidunt suscipit vel varius magna. Vivamus ersa voreau viverra, risus blandit pulvinar pretium, libero augue suscipit diam, quis consectetur nulla urna quis sapien. Etiam semper quis quam vel mattis.</p>
--	--



Produit:Paris | Editor's word

Bright Spark!

Nulla vestibulum eleifend nulla. Suspendisse potenti. Aliquam turpis nisi, venenatis non, accumsan nec, imperdiet laoreet, lacus. In purus est, mattis eget, imperdiet nec, fermentum congue, tortor. Aenean ut nibh. Nullam hendrerit viverra dolor. Vestibulum fringilla, lectus id viverra malesuada, enim mi adipiscing ligula, et bibendum lacus lectus id sem. Cras risus turpis, varius ac, feugiat id, faucibus vitae, massa. Nunc gravida nonummy felis. Etiam suscipit, est sit amet suscipit sodales, est neque suscipit erat, nec suscipit sem enim eget leo. In porttitor rutrum leo. Ut eget leo.



Nulla quis nibh. Proin ac pede vel ligula facilisis gravida. Phasellus purus. Etiam sapien. Duis diam urna, iaculis ut, vehicula ac, varius sit amet, mi. Donec id nisl. Aliquam erat volutpat. Integer fringilla. Duis lobortis, quam non volutpat suscipit, magna sem consequat libero, ac hendrerit urna ante id mi. Quisque commodo facilisis tellus. Integer sodales lorem sed nisl. Morbi consetetuer mauris quis odio. Ut dolor lorem, viverra vitae, viverra eu, euismod nec, enim. Lorem ipsum dolor sit amet, consetetuer adipiscing elit.

Morbi nisl eros, dignissim nec, malesuada et, convallis quis, augue. Vestibulum ante ipsum primis in faucibus orci luctus et ultrices posuere cubilia Curae; Proin aliquam, leo at luctus tempus, eros lectus eleifend massa, quis sollicitudin erat magna non leo. Vestibulum vel metus. Donec sagittis velit vel augue. Fusce in nisl vitae massa venenatis rhoncus. Praesent orci velit, lobortis eget, suscipit semper, congue eu, est. Quisque malesuada volutpat enim. Vestibulum leo sem, molestie a, mattis bibendum, feugiat facilisis, nisl. Nam scelerisque odio. Suspendisse fermentum faucibus felis. Praesent pharetra. In consequat felis in tellus. In mi enim, rhoncus ullamcorper, sagittis at, placerat eget, mauris.

C. Findlay

Best wishes
Calum Findlay
Editor



Produit:Parisonline.com

1 | Produit:Paris | issue 120

Produit  Paris

Inside this month's issue:

congue ac, faucibus ut, erat. Donec sit amet neque. Donec posuere tempus massa. Duis vulputate mauris sit amet purus. Duis vestibulum.



Vestibulum semper enim non eros. Sed vitae arcu. Aliquam erat volutpat. nisl, suscipit at, rhoncus sit amet, porttitor sit, leo. Aenean hendrerit est. Etiam ac augue. Morbi tincidunt neque.



Morbi nisl eros, dignissim nec, malesuada et, convallis quis, augue. Vestibulum ipsum primis in faucibus luctus et ultrices posuere cubilia Curae; Proin aliquam, leo at.



[BLANK PAGE]

DO NOT WRITE ON THIS PAGE

[BLANK PAGE]

DO NOT WRITE ON THIS PAGE

ACKNOWLEDGEMENTS

Q6 Magazine Layout – Smiling man: ESB Professional/Shutterstock.com
Rocking chair: Robert Kneschke/Shutterstock.com
Light bulbs: grmarc/Shutterstock.com
Antique silver jewellery: Ti Santi/Shutterstock.com

Q6 Magazine Layout – Facebook logo.

SQA has made every effort to trace the owners of copyright materials in this question paper, and seek permissions. We will be happy to incorporate any missing acknowledgements. Please contact question.papers@sqa.org.uk.

Q6 Magazine Layout – Twitter logo.

SQA has made every effort to trace the owners of copyright materials in this question paper, and seek permissions. We will be happy to incorporate any missing acknowledgements. Please contact question.papers@sqa.org.uk.