



National  
Qualifications  
2016

---

## 2016 Graphic Communication

### Higher

## Finalised Marking Instructions

© Scottish Qualifications Authority 2016

The information in this publication may be reproduced to support SQA qualifications only on a non-commercial basis. If it is to be used for any other purposes written permission must be obtained from SQA's NQ Assessment team.

Where the publication includes materials from sources other than SQA (secondary copyright), this material should only be reproduced for the purposes of examination or assessment. If it needs to be reproduced for any other purpose it is the centre's responsibility to obtain the necessary copyright clearance. SQA's NQ Assessment team may be able to direct you to the secondary sources.

These Marking Instructions have been prepared by Examination Teams for use by SQA Appointed Markers when marking External Course Assessments. This publication must not be reproduced for commercial or trade purposes.



## General Marking Principles for Higher Graphic Communication

*This information is provided to help you understand the general principles you must apply when marking candidate responses to questions in this paper. These principles must be read in conjunction with the detailed marking instructions, which identify the key features required in candidate responses.*

- (a) Marks for each candidate response must always be assigned in line with these General Marking Principles and the Detailed Marking Instructions for this assessment.
- (b) Marking should always be positive. This means that, for each candidate response, marks are accumulated for the demonstration of relevant skills, knowledge and understanding: they are not deducted from a maximum on the basis of errors or omissions.
- (c) If a specific candidate response does not seem to be covered by either the principles or detailed Marking Instructions, and you are uncertain how to assess it, you must seek guidance from your Team Leader.
- (d) For each candidate response, the following provides an overview of the marking principles. Refer to the Specific Marking Instructions for further guidance on how these principles should be applied.
  - (i) **Questions that ask candidates to describe**  
Candidates must provide a statement or structure of characteristics and/or features. This should be more than an outline or a list. Candidates may refer to, for instance, a concept, experiment, situation, or facts in the context of and appropriate to the question. Candidates will normally be required to make the same number of factual/appropriate points as are awarded in the question.
  - (ii) **Questions that ask candidates to explain**  
Candidates must generally relate cause and effect and/or make relationships between things clear. These will be related to the context of the question or a specific area within a question.
  - (iii) **Questions that ask candidates to compare**  
Candidates must generally demonstrate knowledge and understanding of the similarities and/or differences between, for instance, things, methods, or choices. These will be related to the context of the question or a specific area within a question.
- (e) Candidates can respond to any question using text, sketching, annotations or combinations where they prefer. No marks shall be awarded for the quality of sketching. Marking will relate only to the information being conveyed.

## Marking Instructions for each question

Question			Expected Response	Max Mark	Additional Guidance
1.	(a)		<ul style="list-style-type: none"> <li>• Reduce time required to model each component</li> <li>• Reduce likelihood of CAD technician making errors</li> <li>• Represents actual standard component parts</li> <li>• A library would contain all common component parts</li> <li>• The same parts would be used by all CAD technicians in the company</li> <li>• Library components can be used by CAD users worldwide</li> </ul>	2	<p>Any two points</p> <p>No marks for “much quicker/faster” unless justification is given eg Much quicker as you don’t have to create the components.</p>
	(b)	(i)	<ul style="list-style-type: none"> <li>• Gives a realistic representation of what the final product will look like.</li> <li>• 3D models can be used to create photorealistic renders</li> <li>• 3D models can be used to show different materials, colours and textures</li> <li>• 3D models can be animated</li> <li>• 3D models can be put into different scenes or contexts</li> <li>• Used for promotional material (print or digital)</li> </ul>	1	<p>Any one point</p> <p>Do not accept ‘for advertising’</p>
		(ii)	<ul style="list-style-type: none"> <li>• 3D models can be used to directly manufacture (CNC/CAM)</li> <li>• To enable dimensions to be extracted from the CAD model, without production drawings</li> <li>• 3D models can be used to show how complex items are assembled</li> <li>• 3D models do not need a manufacturer to interpret complex production drawings</li> <li>• Production drawings can be created and fully dimensioned from the CAD model.</li> </ul>	1	<p>Any one point</p> <p>Do not accept ‘for manufacture’, without reference to CNC or CAM technologies.</p> <p>Candidates must justify the purpose of the drawing eg dimensions, tolerances, materials, surface finish.</p>

Question		Expected Response	Max Mark	Additional Guidance
	(c)	<ul style="list-style-type: none"> <li>• Top down modelling allows sizes to be captured from another part, without measuring</li> <li>• Top down modelling allows geometry (form &amp; shape) to be captured without redrawing</li> <li>• Top down modelling ensures the 3D CAD model is automatically assembled</li> <li>• Top down modelling allows the change of one component to automatically update another component</li> <li>• Components can be created in context within an assembly</li> </ul>	2	A generic description of top down modelling can be given or top down modelling in relation to the guitar.
	(d) (i)	Use 'Offset' command	1	
	(ii)	Select the bottom edge of the guitar and set a distance	1	Accept use of offset from bottom edge of guitar.

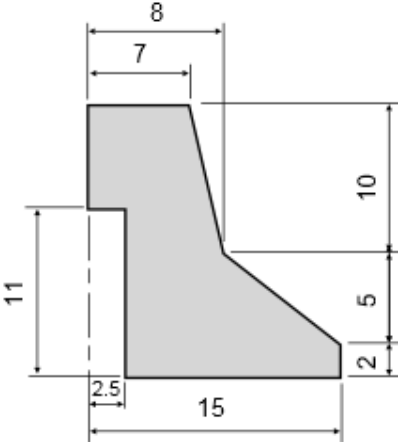
Question	Expected Response	Max Mark	Additional Guidance
(e)	<p><b>Revolve method</b></p> <ul style="list-style-type: none"> <li>Using the revolve command (1 mark)</li> <li>Describing the profile to be revolved, with dimensions (1 mark)</li> <li>Creating a circle on a perpendicular plane and extrude subtract (1 mark)</li> <li>Describing the dimensioning of circle diameter 4mm on the perpendicular workplane and its' position 9mm up from the from the base (1 mark)</li> <li>Creating diameter 5mm circle on the base, extrude subtract to 11mm depth. (1 mark)</li> </ul> <p><b>Creating ridges: Extrude along a path method</b></p> <ul style="list-style-type: none"> <li>Create circle for ridge on top face (1 mark)</li> <li>Creating a sketch-path to correct length, extrude-along-a-path (subtract) (1 mark)</li> <li>Radial Array ridge feature 38 times over PCD 14 (1 mark)</li> </ul>	8	 <p>Candidate who added this feature in the revolve will also be awarded this 1 mark</p>

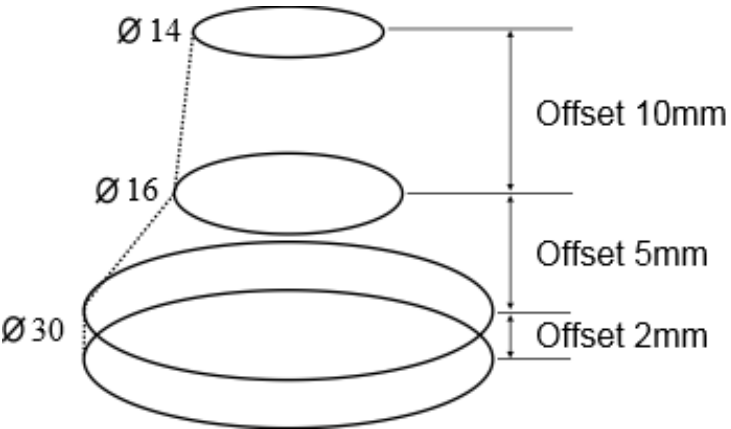
Question	Expected Response	Max Mark	Additional Guidance
(e)	<p><b>Loft Method</b></p> <ul style="list-style-type: none"> <li>Using the loft command (1 mark)</li> <li>Describing relevant dimensions, 3 offset distances for 4 workplanes (1 mark)</li> <li>Creating a circle on a perpendicular plane and extrude subtract (1 mark)</li> <li>Describing the dimensioning of circle diameter 4mm on the perpendicular workplane and its' position 9mm up from the from the base (1 mark)</li> <li>Creating diameter4 5mm circle on the base, extrude subtract to 11mm depth. (1 mark)</li> </ul> <p>Creating ridges: <b>Loft method</b></p> <ul style="list-style-type: none"> <li>Create circle for ridge on top face (1 mark)</li> <li>Creating bottom circle and loft between profiles (subtract) (1 mark)</li> <li>Radial Array ridge feature 38 times over PCD 14 (1 mark)</li> </ul>	8	<p>(Also accept extrude for bottom lip and loft between 3 workplanes)</p> 

Question		Expected Response	Max Mark	Additional Guidance
(f)	(i)	Correct symbol Correct position (1 mark)	1	Both for 1 mark
	(ii)	Correct symbol Correct position (1 mark)		
			1	Both for 1 mark
(g)	(i)	90mm	1	
	(ii)	12mm	1	
(h)		Describing using loft command (1 mark) Describing workplanes offset (1 mark) Describing profiles (1 mark)	3	No marks for extrude (question asks for single modelling technique)  Candidates can still be awarded marks for workplane and loft where extrude has been used for the first segment

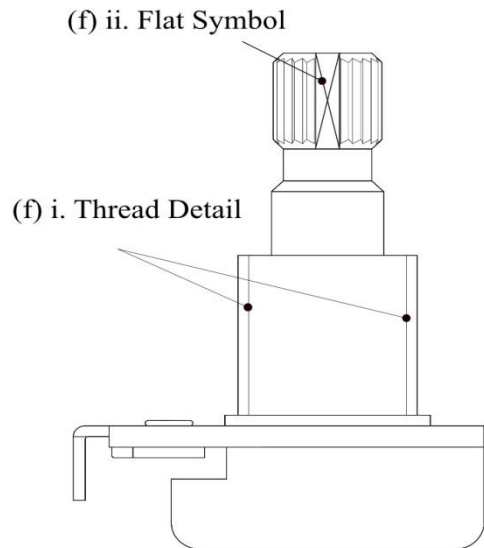

Question			Expected Response	Max Mark	Additional Guidance
2.	(a)	(i)	<ul style="list-style-type: none"> <li>• Area of white space underneath “fab” emphasises the heading and attracts the eye to it</li> <li>• Area of white space bleeds from left page onto the right</li> <li>• Area of white space creates breathing space/a rest for the eye</li> <li>• Areas of white space make the page look less cluttered</li> </ul> <p>Triangular white space creates</p> <ul style="list-style-type: none"> <li>• Balance</li> <li>• Interest</li> <li>• Rhythm</li> </ul>	2	Any two
		(ii)	<ul style="list-style-type: none"> <li>• Warm colour yellow is used that has connotations of summer and warmth</li> <li>• Harmonious colour scheme</li> <li>• The repeated use of the colour yellow creates unity in the layout</li> <li>• Contrast in colours on sunglasses blue and yellow</li> </ul>	2	Any two
		(iii)	<ul style="list-style-type: none"> <li>• Sans serif fonts used for FAB title. Its’ simplicity works well with the image behind it.</li> <li>• The layout has a combination of serif and sans serif and script fonts creating a stylised feel - reflecting the target market</li> <li>• Contrasting fonts in the layout create visual interest</li> </ul>	2	When referring to a specific typeface, candidates must mention serif, sans serif or script fonts  Any two

Question	Expected Response	Max Mark	Additional Guidance
(b)	<ul style="list-style-type: none"> <li>• Emphasis created by enlarged heading being larger than all other elements</li> <li>• Triangular images very similar in size, helping to create unity/consistency - also means that no image is more dominant than the other</li> <li>• Areas of body text are similar in size which helps create consistency and balance</li> <li>• Enlarged cropped images within triangular frames creates visual interest</li> </ul>	4	
(c)	<ul style="list-style-type: none"> <li>• Pictorial/perspective view of the sunglasses themselves give the illusion of depth against the flat background</li> <li>• Drop shadow on RayBan logo yellow background</li> <li>• Drop shadow on sunglasses image</li> <li>• Drop shadow on bottom yellow box</li> <li>• Image behind FAB transparency gives depth</li> <li>• Transparencies added to top-left image creates illusion of depth</li> <li>• Different sizes of figures in images creates depth</li> </ul>	2	<p>Any two</p> <p>Do not accept drop shadow on its' own</p>
(d)	<ul style="list-style-type: none"> <li>• The yellow colour of the line creates unity with other yellow elements on the page</li> <li>• The line draws the readers eye from left to right and around the image</li> <li>• The stroke/thickness of the line is consistent and narrow meaning it is not overpowering/dominant</li> <li>• Angle of lines create interest/shape on the page</li> <li>• Lines are used to emphasise the triangular image and the triangular white space</li> <li>• Lines separate/split elements on the page</li> </ul>	2	Any two

Question		Expected Response	Max Mark	Additional Guidance	
	(e)	<ul style="list-style-type: none"> <li>• Scalable without pixelation</li> <li>• The red background could be easily changed to yellow within the DTP software. Had the image been a bitmap it would have to have been edited using specialist software</li> <li>• The white text can be made transparent within the DTP software</li> <li>• The red background could be stretched easily within the DTP software without the need for prior editing in another package</li> </ul>	2	Any two	
	(f)	<ul style="list-style-type: none"> <li>• Text and images can be edited separately</li> <li>• Layers can be turned on and off to improve clarity during the production of the layout</li> <li>• The mask for “FAB” could be easily created</li> <li>• The layers can provide a master-page for similar future layouts</li> <li>• Edit layers without effecting other parts of the layout</li> <li>• Layers can be reordered, moved to front, moved to back</li> </ul>	3	Any three	
	(g)	(i)	Centred justification for all the text on the left-hand page creates balance and/or symmetry or alignment or contrast	1	No mark for simply stating centred justification
		(ii)	<ul style="list-style-type: none"> <li>• Fully-justified text provides neatness as there are no “jagged” edges on the sides of columns</li> </ul>	1	No mark for simply stating full justification
	(h)	(i)	<ul style="list-style-type: none"> <li>• No white spaces will appear outside of the yellow boxes after cropping</li> </ul>	1	
		(ii)	<ul style="list-style-type: none"> <li>• To allow the multicolour printing to be set up correctly.</li> <li>• Each register mark should overprint exactly for accurate registration</li> </ul>	2	

Question		Expected Response	Max Mark	Additional Guidance
3.	(a)	<p>Answer should summarise points that will include:</p> <p><b>CAD location plans show</b></p> <ul style="list-style-type: none"> <li>• Location of building in relation to streets</li> <li>• Location of building in relation to other buildings</li> <li>• Size of building to scale</li> <li>• Contours show the slope in the land</li> <li>• Geographical features eg rivers, woodland, greenbelt</li> <li>• Position of existing railways, bridges</li> <li>• North Symbol will show the direction the building is facing</li> </ul> <p><b>CAD site plans show</b></p> <ul style="list-style-type: none"> <li>• Proposed building in relation to the property boundaries</li> <li>• Size and position of the building</li> <li>• Position of drainage</li> <li>• Landscape elements</li> <li>• Gas, electrical and water supplies</li> <li>• Contours show the slope in the land</li> <li>• Trees shown in position</li> <li>• North Symbol will show the direction the building is facing</li> <li>• Size of the building and site to scale</li> </ul>	4	<p>Candidates should give two answers from location and two from site plan for the 4 marks</p> <p>No mark should be awarded for simply stating the scale</p> <p>No marks awarded for simply stating a feature</p> <p>No repetition of answers</p>

Question		Expected Response	Max Mark	Additional Guidance
	(b)	<ul style="list-style-type: none"> <li>• Photo real image of how the building will look</li> <li>• Realistic representation of materials</li> <li>• Adjacent buildings shown</li> <li>• Building is shown in its proposed environment</li> <li>• Shows adjacent roads and direction of traffic flow</li> <li>• Realistic representations of different lighting conditions day time, night time.</li> <li>• Useful for users who cannot read or interpret 2D drawings such as floor plans, site plans and location plans</li> <li>• Rendered CAD pictorials can be sent out to the community by email</li> </ul>	3	Any three points for 3 marks
	(c) (i)	The sketches would have to be captured/scanned using a suitable device (flatbed, hand, photocopier used as a scanner, digital camera, digitiser/graphics tablet)	1	No marks for simply stating the hardware device candidates must mention the use of the device
	(ii)	<ul style="list-style-type: none"> <li>• Jpeg files are compressed</li> <li>• Jpeg files are a small size</li> <li>• Jpeg is a common file type</li> <li>• Jpegs are easily accessible without any specialist software</li> </ul>	1	
	(d)	<ul style="list-style-type: none"> <li>• The sketches could include realistic material representations</li> <li>• They can be built up in a series of layers to ease editing</li> <li>• They are automatically stored electronically and do not require scanning to upload to the website</li> <li>• Able to show client changes instantly</li> <li>• Sketches can be exported into other packages</li> <li>• Easy to share through email</li> </ul>	2	Any two points

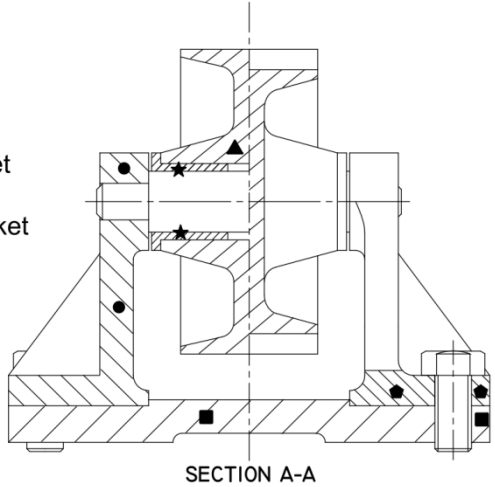
Question	Expected Response	Max Mark	Additional Guidance
4.	<p>1 mark for each correctly sectioned component (5 in total)</p> <ul style="list-style-type: none"> <li>▲ 1 mark Pulley</li> <li>★ 1 mark Bush</li> <li>● 1 mark Left Bracket</li> <li>■ 1 mark Base</li> <li>◆ 1 mark Right Bracket</li> </ul>  <p style="text-align: center;">SECTION A-A</p>	5	<p>No marks deducted for extra areas hatched</p> <p>Each component which has two areas hatched, the hatching style must match</p> <p>Clear distinction between components should be reflected in the hatching style applied</p>

Question		Expected Response	Max Mark	Additional Guidance
5.	(a)	Symbols for existing trees OR proposed trees OR trees to be removed OR trees accepted North symbol Contour lines Boundary lines	3	Accept any type of tree in this question as candidates cannot tell from the plan if they are existing, proposed or to be removed.  Any three
	(b)	Four	1	
	(c)	(i)	1	Insulated board, Insulation board
		(ii)	1	Towel rail
		(iii)	1	Drainage

[END OF MARKING INSTRUCTIONS]