



Higher  
Coursework  
Assessment Task



---

# Higher Engineering Science Assignment Finalised Marking instructions

© Scottish Qualifications Authority 2024

These marking instructions have been prepared by examination teams for use by SQA appointed markers when marking external course assessments.

The information in this document may be reproduced in support of SQA qualifications only on a non-commercial basis. If it is reproduced, SQA must be clearly acknowledged as the source. If it is to be reproduced for any other purpose, written permission must be obtained from [permissions@sqa.org.uk](mailto:permissions@sqa.org.uk).

## General marking principles

This information is provided to help you understand the general principles that must be applied when marking candidate responses in this assignment. These principles must be read in conjunction with the detailed/specific marking instructions, which identify the key features required in candidate responses.

- a Marks for each candidate response must always be assigned in line with these general marking principles and the specific marking instructions for this assessment.
- b Marking should always be positive. This means that, for each candidate response, marks are accumulated for the demonstration of relevant skills, knowledge and understanding: they are not deducted from a maximum on the basis of errors or omissions.
- c If a specific candidate response is not covered by either the general marking principles or detailed marking instructions, you must seek guidance from your team leader.

### Detailed marking instructions

Task		Expected answer(s)	Max mark	Additional guidance
1	a	<p>The system must:</p> <p><b>Input:</b></p> <ol style="list-style-type: none"> <li>1. Detect the wind direction</li> <li>2. Sense the turbine head position</li> <li>3. Send both signals to the control unit</li> </ol> <p><b>Process:</b></p> <ol style="list-style-type: none"> <li>4. Use proportional control</li> <li>5. Make use of negative feedback</li> <li>6. Use closed loop control</li> <li>7. Compare turbine head position with the wind direction</li> <li>8. Use a driver to amplify the signal to the motor</li> </ol> <p><b>Output:</b></p> <ol style="list-style-type: none"> <li>9. Start to move the motor/ turbine head quickly</li> <li>10. Slow the motor as the turbine head position gets closer to the desired position</li> <li>11. Turn the motor to rotate the turbine head</li> <li>12. Stop the motor when the turbine head is in the correct position</li> <li>13. Use a driver to spin the motor in both directions</li> </ol>	6	1 mark for each correct point (max 6 points).

Task		Expected answer(s)	Max mark	Additional guidance
1	b	<p>variable voltage supply <math>V_1</math></p> <p>variable voltage supply <math>V_2</math></p> <p>0V</p>	3	<p>1 mark - op-amp in difference configuration with <math>V_1</math> connected to inverting input and <math>V_2</math> connected to non-inverting input.</p> <p>1 mark - <math>R_f</math> and <math>R_i</math> resistors correctly connected, with appropriate resistor values giving gain of 30.</p> <p>1 mark - + 9 V and -9 V op-amp supplies (terminals not required).</p>

Task		Expected answer(s)	Max mark	Additional guidance
1	c	<p>The diagram shows an inverting operational amplifier circuit. The non-inverting input (+) is connected to a biasing network consisting of a 9 V DC supply, a 1 kΩ resistor, and a 30 kΩ resistor connected to ground. The inverting input (-) is connected to a 10 kΩ resistor that receives a 10 mV AC input signal. A feedback resistor of 300 kΩ is connected between the output and the inverting input. The output is measured by a voltmeter, which displays a reading of 0.00 μV. A 0 V reference point is also indicated at the bottom left of the circuit.</p>	2	<p>FTE applied for correct simulation from design in Q1(b).</p> <p>1 mark - input and output (variable supplies and voltmeter).</p> <p>1 mark - op-amp (with resistor values and supply voltages from Q1(b)).</p> <p>Second mark not available if comparator configuration is used due to simplification of simulation.</p>

Task		Expected answer(s)				Max mark	Additional guidance
1	d	Planned test	Expected result	Actual result	Amendments made	4	Marked based on the circuit provided in 1(c).  1 mark - correct actual result.  1 mark - correct actual result.  1 mark - correct amendment.    1 mark - correct actual result based on test 2 amendments.
		Set both $V_1$ and $V_2$ to 5 mV.	The output voltage is 0 V.	The output voltage is 0 V.	None required.		
		Set $V_1$ to 10 mV and set $V_2$ to 0 mV.	The output voltage should be + 300 mV.	The output voltage is -300 mV.	Alter the circuit by adding a further op-amp in an inverting configuration after the first op-amp.  OR  Swapping the inputs to the op-amp so that $V_1$ is connected to the non-inverting input and $V_2$ is connected to the inverting input.		
		Set $V_1$ to 4 mV and set $V_2$ to 6 mV.	The output voltage should be - 60 mV.	The output voltage is - 60 mV.	None required.		

Task		Expected answer(s)	Max mark	Additional guidance
1	e	<p>iv - the op-amp initially had a gain of 30, achieved by the ratio of <math>R_f</math> and <math>R_i</math> values, 30:1. The circuit works as specified, and this specification is fully met.</p> <p>v - the op-amp has both a positive and negative supply voltage which allows for a positive or negative output voltage. As the circuit can produce both 300 mV and 60 mV output voltages, this specification point is met.</p> <p>Overall, the system performs well to meet the specification after amendments - the voltage changes polarity correctly as <math>V_1</math> and <math>V_2</math> are altered, the gain is correct, and the voltage magnitude increases and decreases as required.</p> <p>However, the system could be improved with an emergency braking system/ override switch to prevent any damage to parts. The system could be improved by adding warning lights/ buzzer when the turbine head is in motion.</p>	4	<p>1 mark - identification of how specification iv is met.</p> <p>1 mark - describing how specification v is met.</p> <p>1 mark - evaluative comments on overall effectiveness.</p> <p>1 mark - practical suggestion for improvement.</p>

Task	Expected answer(s)	Max mark	Additional guidance
2 a	<p style="text-align: center;">Flowchart_1</p> <pre> graph TD     Start([Start PIC 100 010]) --&gt; D1{a_Input1 &gt; 128 ?}     D1 -- Y --&gt; S1[/Set: Output6 On, Output7 Off/]     D1 -- N --&gt; D2{a_Input1 = 128 ?}     D2 -- Y --&gt; S2[/Set: Output6 Off, Output7 Off/]     D2 -- N --&gt; D3{a_Input1 &lt; 128 ?}     D3 -- Y --&gt; S3[/Set: Output7 On, Output6 Off/]     D3 -- N --&gt; D4{a_Input0 ≥ 100 ?}     D4 -- Y --&gt; S4[/Set: Output0 On/]     D4 -- N --&gt; D5{a_Input0 &lt; 100 ?}     S4 --&gt; D5     D5 -- Y --&gt; S5[/Set: Output0 Off/]     D5 -- N --&gt; D1     S1 --&gt; D1     S2 --&gt; D2     S3 --&gt; D3     S5 --&gt; D1   </pre>	4	1 mark - must match flowchart as given in task.

Task	Expected answer(s)	Max mark	Additional guidance
2 a			<p>1 mark - digital input (switch with 10 kΩ resistor in series) and 5 V supply.</p> <p>1 mark - two analogue inputs (10 kΩ potentiometer to analogue input 1, LDR and 5 kΩ resistor in series, to analogue input 0).</p> <p>1 mark - output motor circuit with 5 V supply and solenoid circuit with 9 V supply.</p>

Task		Expected answer(s)				Max mark	Additional guidance
2	b	Planned test	Expected result	Actual result	Amendments made	7	<p>Marks based on circuit given in the question.</p> <p>1 mark - correct actual result with descriptive reference to the 'master' switch.</p> <p>1 mark - correct amendment with location of decision.</p> <p>1 mark - correct actual result.</p> <p>1 mark - correct first amendment.</p> <p>1 mark - correct second amendment.</p>
		Activate the flowchart. Press the 'master' switch.	The robot program will run.	The robot program does run, but there is no 'master' switch decision to start it.	Decision box inserted to test input 7 ('master' switch) operation after start terminus.		
		Alter analogue input 1 maximum value, then activate the flowchart. Press the 'master' switch.	Output 7 switches on and the motor turns.	Output 6 switches on and the motor turns.	<p>The outputs are inverted ie 'output 6 on, output 7 off' to 'output 6 off, output 7 on' and therefore 'output 6 off, output 7 on' to 'output 6 on, output 7 off'.</p> <p>OR</p> <p>The inequalities are inverted ie '&gt;' to '&lt;' and therefore '&lt;' to '&gt;'.</p>		

Task		Expected answer(s)				Max mark	Additional guidance
2	b	Alter analogue input 0 LDR to the maximum light level, then activate the flowchart. Press the 'master' switch. Repeat this test.	The solenoid will energise and actuate each time.	The solenoid energises once and the transistor fails/ explodes. This was not repeatable.	An 18 k $\Omega$ base resistor is added to the transistor, and a diode in parallel with solenoid.		<p>1 mark - correct actual result must refer to transistor, solenoid and repeatability.</p> <p>1 mark - correct amendment with base resistor value 18 k<math>\Omega</math> (or greater) and diode.</p> <p>Note:</p> <ol style="list-style-type: none"> <li>1. MOSFET can replace transistor along with diode parallel to solenoid.</li> <li>2. Collector resistor (value minimum 150 <math>\Omega</math>) can be used to prevent failure of transistor.</li> <li>3. Alternative simulation software may require different base resistor values (greater than 7.6 k<math>\Omega</math>) and fly away diode parallel to solenoid.</li> </ol>

Task		Expected answer(s)	Max mark	Additional guidance
2	c	<p><b>Specification point i.</b></p> <p>The robot operated without pressing the ‘master’ switch. There was an error in the flowchart program, which was corrected by adding a decision box to confirm input 7 is on. The robot now works as specified, and specification i is now fully met.</p> <p><b>Specification point ii.</b></p> <p>The input control did enable the motor to switch on and off at the correct levels, but rotated in the wrong direction. This was corrected by changing outputs 6 to ‘off’ and output 7 to ‘on’ when analogue input 1’s value is greater than 128. After this change, specification ii is fully met.</p> <p>However, to ensure the flowchart works fully, output 6 was changed to ‘on’ and output 7 changed to ‘off’ when analogue input 1’s value was less than 128.</p> <p><b>Specification point iii.</b></p> <p>The solenoid did not operate as specified as the transistor was damaged as it turns on. This was corrected by adding a base resistor to prevent a large current flowing to the base of the transistor. Specification iv is now fully met.</p>	4	<p>1 mark - evaluative statement including the identification of the error and correction.</p> <p>1 mark - evaluative statement including the identification of the error and correction.</p> <p>1 mark - consequential amendment.</p> <p>1 mark - evaluative statement including the identification of the error and correction.</p>

Task	Expected answer(s)	Max mark	Additional guidance												
3	 <div data-bbox="365 817 1243 1173" style="background-color: #2c3e50; color: white; padding: 10px;"> <p><b>Reactions</b> <span style="float: right;">✔ Results Verified </span></p> <table border="1" style="width: 100%; border-collapse: collapse; text-align: center;"> <thead> <tr> <th>Support at</th> <th>X</th> <th>Y</th> <th>Mx</th> </tr> </thead> <tbody> <tr> <td>0</td> <td>0 kN</td> <td>55.508 kN</td> <td>0 kN-m</td> </tr> <tr> <td>6</td> <td>0 kN</td> <td>95.492 kN</td> <td>0 kN-m</td> </tr> </tbody> </table> </div>	Support at	X	Y	Mx	0	0 kN	55.508 kN	0 kN-m	6	0 kN	95.492 kN	0 kN-m	3	<p>1 mark - simulation which includes UDL, point load and two supports (reaction forces acceptable).</p> <p>1 mark - correct data entered on simulation.</p> <p>1 mark - correct reactions at A (55.5 kN) and B (95.5 kN).</p>
Support at	X	Y	Mx												
0	0 kN	55.508 kN	0 kN-m												
6	0 kN	95.492 kN	0 kN-m												

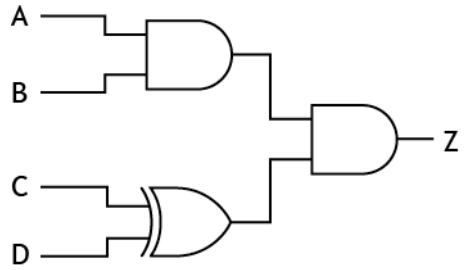
Task		Expected answer(s)	Max mark	Additional guidance
4	a	 <p>The diagram shows a logic circuit with four inputs: A, B, C, and D. Inputs A and B are connected to an AND gate. Inputs C and D are connected to an XOR gate. The outputs of these two gates are connected to a third AND gate, which produces the final output Z.</p>	2	<p>1 mark - both AND gates correct with connections.</p> <p>1 mark - XOR correct with connections.</p>

Task	Expected answer(s)	Max mark	Additional guidance
4 b		8	<p>1 mark - <math>V_3</math> with correct actuators, plus connection to <math>C_B</math>.</p> <p>1 mark - single-acting cylinder, showing outstroke direction correctly.</p> <p>1 mark - <math>V_1</math> with correct actuators, connected to <math>V_2</math>.</p> <p>1 mark - <math>V_2</math> with correct actuators, connected to 5/2 valve.</p> <p>1 mark - <math>V_4</math> with correct actuators, connected to pin 4 and 5/2 valve.</p> <p>1 mark - UDR on <math>C_A</math> outstroke exhaust.</p> <p>1 mark - correct line types to indicate main air going to both cylinders and pilot air to 5/2 valve.</p> <p>1 mark - connection of 5/2 valve to double-acting cylinder <math>C_A</math>.</p>

Task		Expected answer(s)		Max mark	Additional guidance
4	c	<b>Planned test</b>		<b>3</b>	<p>1 mark - correct test and expected result (no mark if valve or lever are not described as actuated, or speed of outstroke is not specified).</p> <p>1 mark - correct test and expected result (must indicate correct duty cycle, must relate signal from pin 7/ valve V<sub>3</sub>).</p> <p>1 mark - correct test and expected result (V<sub>2</sub> unactuated must be specified).</p>
		<b>Expected result</b>			
		Set pin 6 high/ actuate V <sub>1</sub> , and actuate V <sub>2</sub> .	Cylinder C <sub>A</sub> slowly outstrokes.		
		Send a PWM signal with a mark:space ratio of 1:3 (25%) from pin 7.	Cylinder C <sub>B</sub> instrokes and outstrokes repeatedly with the PWM ratio.		
Set pin 4 high/ actuate V <sub>4</sub> , and unactuate V <sub>2</sub> .	Cylinder C <sub>A</sub> instrokes.				

[END OF MARKING INSTRUCTIONS]