



Higher Engineering Science Assignment

Assessment task: wildlife filming

This document provides information for teachers and lecturers about the coursework component of this course in terms of the skills, knowledge and understanding that are assessed. It must be read in conjunction with the course specification.

Valid for session 2019-20 only.

This assessment is given to centres in strictest confidence. You must keep it in a secure place until it is used.

This edition: January 2020 (version 1.0)

© Scottish Qualifications Authority 2020

Contents

Introduction	1
Instructions for teachers and lecturers	2
Instructions for candidates	5
Worksheets	24

Introduction

This document contains instructions for teachers and lecturers, and instructions for candidates for the Higher Engineering Science assignment. It must be read in conjunction with the course specification.

This assignment has 50 marks out of a total of 160 marks available for the course assessment.

This is one of two course assessment components. The other component is a question paper.

Instructions for teachers and lecturers

This task is valid for session 2019-20 only. Once complete, you must send the assignment responses to SQA to be marked.

You must conduct the assignment under a high degree of supervision and control.

This means:

- ◆ all candidates must be within your direct sight
- ◆ candidates must not interact with each other
- ◆ candidates must not have access to e-mail, the internet and mobile phones
- ◆ candidates must complete their work independently – no group work is permitted
- ◆ classroom display materials that might provide assistance must be removed or covered
- ◆ there must be no interruption for learning and teaching
- ◆ candidates must be in a classroom environment

Time

Candidates have 8 hours to complete the assignment, starting at an appropriate point in the course after all content has been delivered. Once candidates begin their assignment, they must continue in each subsequent class period until the permitted time allocation has been used up.

You have a responsibility to manage candidates' work, distributing it at the beginning and collecting it at the end of each period, and storing it securely in-between. This activity does not count towards the total time permitted for candidates to complete the assignment.

Resources

This is a closed-book assessment. Candidates must not have access to learning and teaching materials, the internet, notes, exemplar materials, resources on classroom walls or anything similar.

A data booklet containing relevant data and formulae is available on the Higher Engineering Science subject page on SQA's website. This can be used for the assignment.

Each assessment task includes instructions and details of any equipment or materials required for the assignment. Candidates can also use normal classroom equipment, software and hardware (such as drawing instruments, pneumatics, mechanisms and electronics kit, simulation software, and PCs to run the software) to complete the tasks.

There may be instances where restriction of internet and/or network use is not practical or feasible (for example, if you have a local authority-managed network with specific limitations, software that is web-based, or something similar), however, it remains your professional responsibility to make every effort to meet the assessment conditions.

Reasonable assistance

Candidates must progress through each stage of the assignment without your intervention or guidance, having acquired the skills earlier in the course.

Once candidates complete the assignment, you must not return it to them for further work. You must not provide feedback to candidates or offer your opinion on the perceived quality or completeness of the assignment response at any stage.

You can provide reasonable assistance to support candidates with the following aspects of their assignment:

- ◆ printing, collating and labelling their evidence to ensure it is in the format specified by SQA
- ◆ ensuring candidates have all the materials and equipment required to complete the assignment
- ◆ understanding the information outlined in these instructions

Evidence

All candidate evidence (whether created manually or electronically) must be submitted to SQA in paper-based format.

Each task details what evidence is required and how many pages are expected. This is a guide to ensure that candidates do not produce too much or spend too long on a single task.

Candidates must submit single-sided A4 pages. The pages must not have anything fixed to them. Any screenshots, simulation printouts and/or images must be clear and easy to read.

Alteration or adaptation

You must not alter, adapt or modify the assignment in any way. This includes moving the content of the assignment into a different format or workbook. All candidates must undertake the assignment exactly as it is provided by SQA.

Submission

Each piece of work must be labelled with the task number, for example task 2a, and the back of each page must be clearly labelled with the candidate's details.

Photographs must show the candidate's name next to the piece of work.

Only pages containing candidate evidence are to be submitted and evidence must be submitted in task order.

Volume

There is no word or page count.

Specific instructions for teachers and lecturers: 2019-20 assignment

You must follow these specific instructions. You must ensure that candidates are aware of the assessment conditions and know what they should do for each task, and any specific information contained in this section.

This assignment has **four** mandatory tasks. Candidates can complete the tasks in the order presented or in an order that helps manage classroom equipment.

Each task has a notional time allocated to it – this provides an indication of how long candidates should spend on the task.

All tasks must be completed on A4 single-sided paper or the worksheet provided, with the task number clearly labelled.

Any evidence printed (screenshots or images) **must be clear and easy to read**.

Task 1 (17 marks)

Notional time: 2 hours

- ◆ task 1: completed on up to five single-sided A4 pages
- ◆ tasks 1a, 1c and 1e: a worksheet is provided for each task
- ◆ task 1e: candidates **must not use simulation software** for this task

Task 2 (10 marks)

Notional time: 1 hour 30 minutes

- ◆ task 2: completed on up to six single-sided A4 pages
- ◆ task 2b and 2d: a single worksheet is provided for both these tasks

Task 3 (21 marks)

Notional time: 4 hours

- ◆ task 3: completed on up to four single-sided A4 pages
- ◆ task 3a: In the flowchart, the analogue values '100' and '200' can be replaced with 2V and 4V respectively or other equivalent values depending on the software being used
- ◆ task 3b: a worksheet is provided for this task

Task 4 (2 marks)

Notional time: 30 minutes

- ◆ task 4: completed on up to two single-sided A4 pages
- ◆ task 4: candidates **must use simulation software for this task**

Note: electronically-generated evidence (for example, simulations and coding) is included in the expected number of pages for each task. This must be printed off and compiled for uplift by SQA.

Instructions for candidates

This assessment applies to the assignment for Higher Engineering Science.

The assignment has 50 marks out of a total of 160 marks for the course assessment.

It assesses the following skills, knowledge and understanding:

- ◆ demonstrating engineering science skills and creativity
- ◆ analysing engineering problems
- ◆ designing and building (simulating and/or constructing) solutions to engineering problems
- ◆ testing and evaluating solutions to engineering problems

This is a closed-book assessment. Your teacher or lecturer will let you know how the assessment will be carried out and any specific conditions for doing it.

In this assessment, you have to:

- ◆ analyse a problem
- ◆ design a solution to the problem
- ◆ simulate or construct your solution
- ◆ test your solution
- ◆ evaluate your work

You have 8 hours to complete the assignment. The time to set and clear away equipment you need, and for any printing that is necessary, does not count towards the 8 hours.

You should complete all of the tasks in the order presented, unless otherwise instructed.

The assignment has four tasks, with marks allocated as follows:

Task 1 – 17 marks: analysis, building, testing, and designing a solution (analogue electronics)
(analysis = 6 marks, building = 2 marks, testing = 5 marks, designing a solution = 4 marks)

Task 2 – 10 marks: building, testing, designing a solution and evaluating (digital electronics and programmable control)
(building = 2 marks, testing = 2 marks, designing a solution = 2 marks, evaluating = 4 marks)

Task 3 – 21 marks: building, testing, designing a solution and evaluating (electronics and programmable control)
(building = 6 marks, testing = 6 marks, designing a solution = 3 marks, evaluating = 6 marks)

Task 4 – 2 marks: building a solution (structures and forces)
(building = 2 marks)

For each task, you are provided with an engineering science context or situation.

Submitting your work

Your teacher or lecturer will let you know the approximate amount of time to spend on each task, along with any specific information you need and an indication of the number of single-sided A4 pages of evidence that you should produce.

You must label each piece of your work with the task number (for example, task 2a), and on the back of each page include your:

- ◆ name
- ◆ date of birth
- ◆ Scottish Candidate Number (SCN)
- ◆ centre name
- ◆ centre number

Candidate data sheets – wildlife filming

You can use these data sheets and SQA’s Higher Data Booklet when completing this assignment. **No other resource material is permitted.**

Electronic components

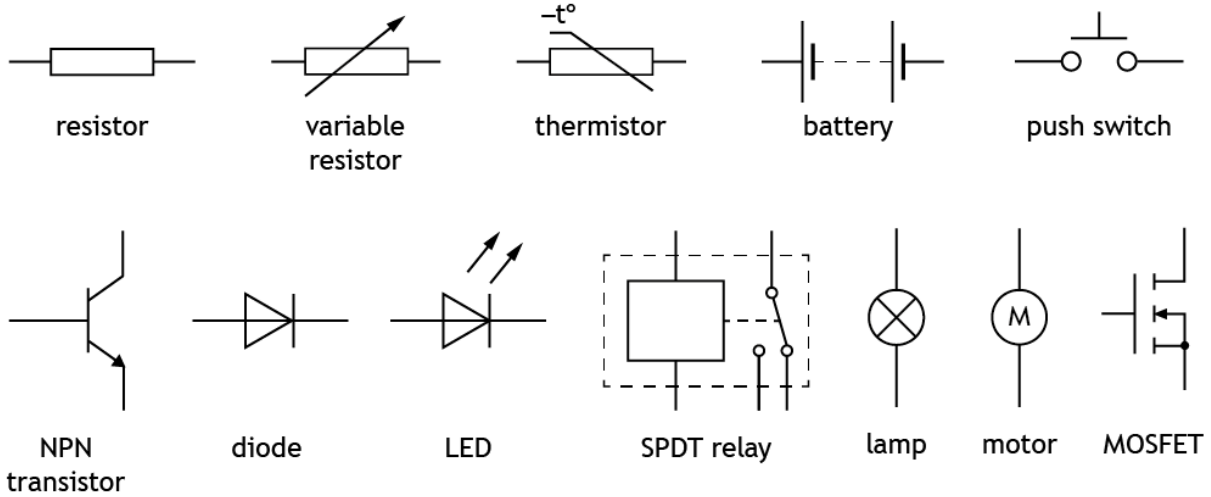

IC pinout diagrams

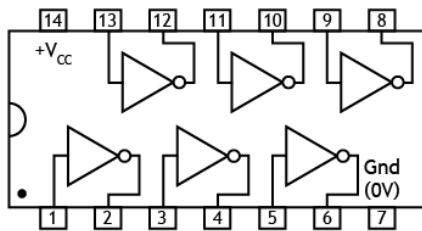

7404

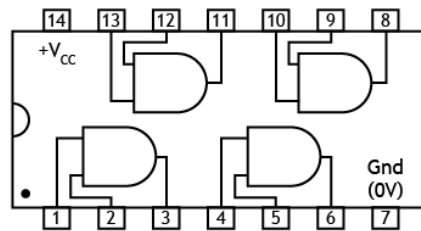

7408

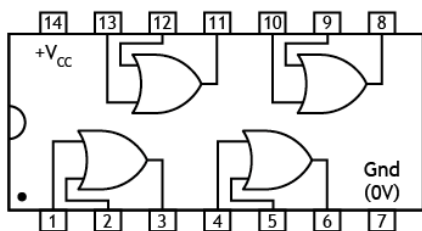

7432

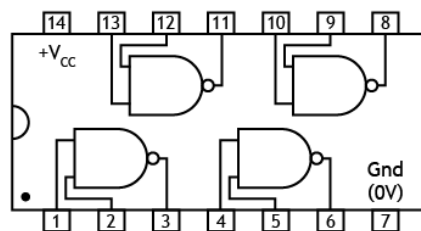

7400

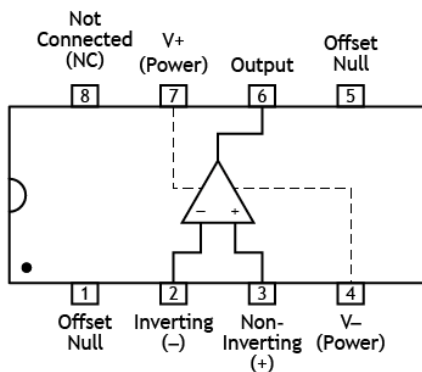

741

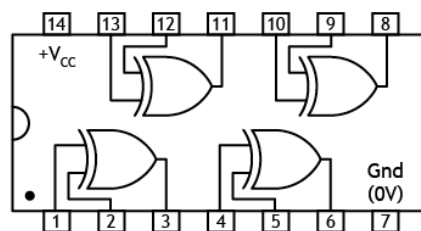

7486

Logic gates

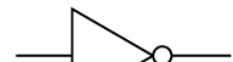

NOT gate

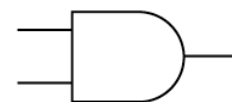

AND gate

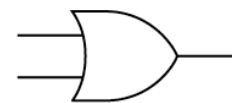

OR gate

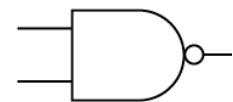

NAND gate

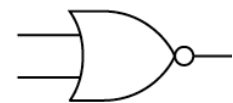

NOR gate



XOR gate

Thermistor graph

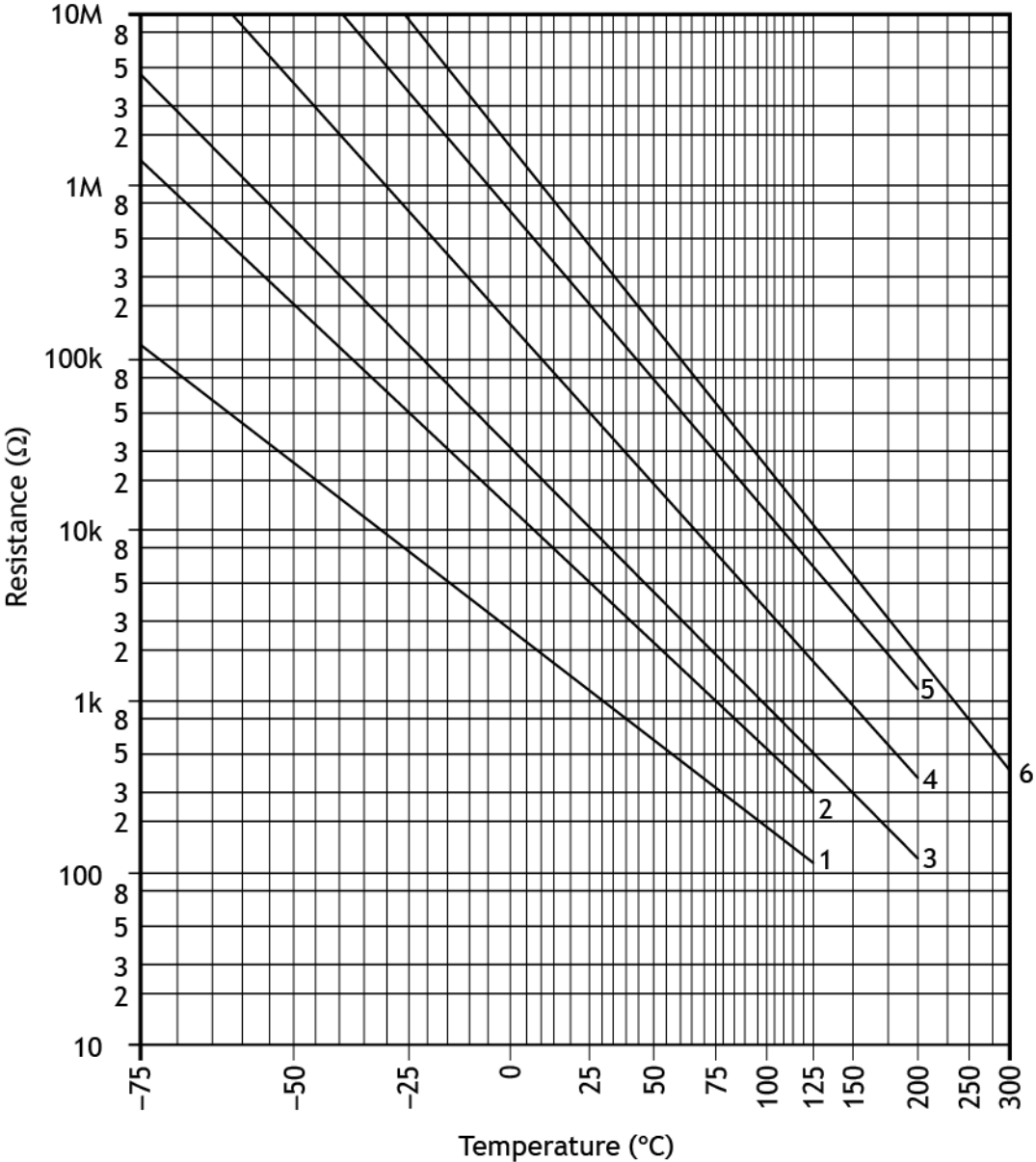

Light Dependent Resistor (LDR) graph for an ORP12 LDR

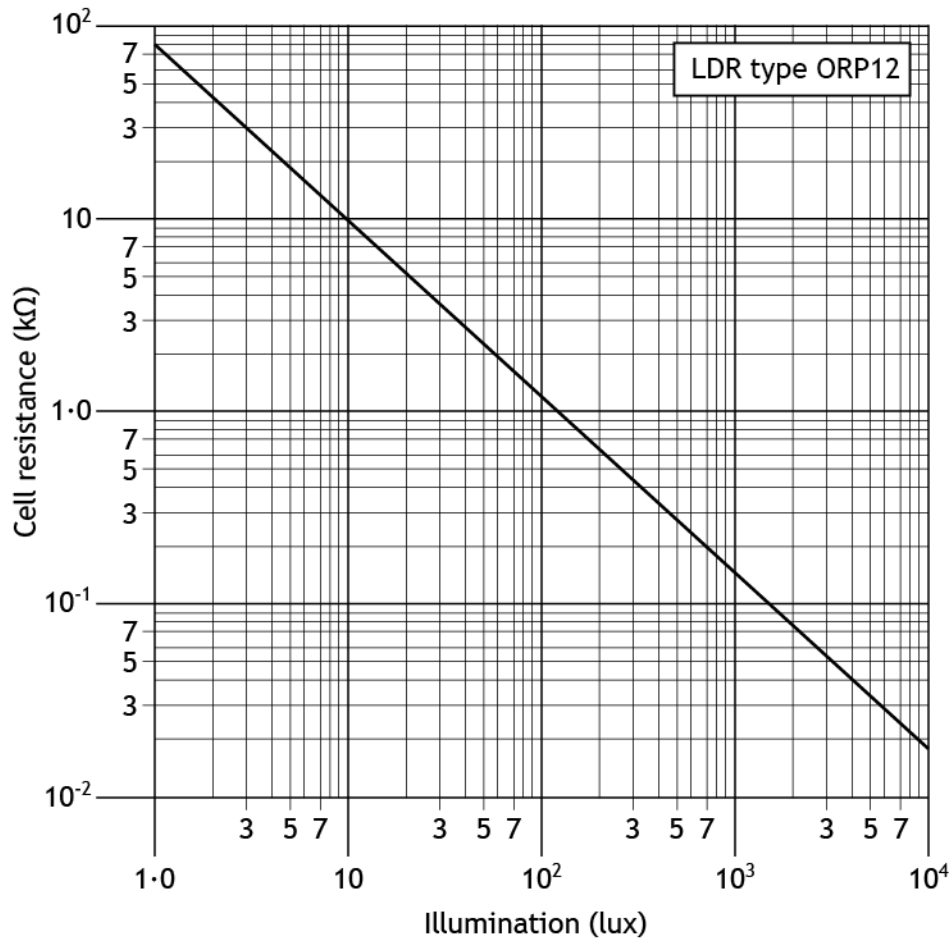

Pneumatic components

Actuators



solenoid



plunger



diaphragm



spring
return

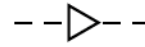

pilot air



Push button

Valves

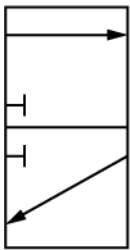

3/2 valve

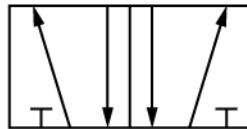

5/2 valve



main air



exhaust

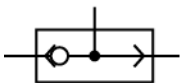

Shuttle
Valve

Components and cylinders



unidirectional
restrictor



reservoir

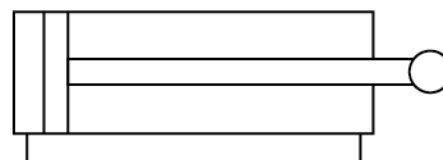

double acting cylinder

Wildlife filming

A team of engineers is developing equipment to allow a TV crew to film animals in the wild.

They need to develop a camera tracking system to allow the filming of the animals and a humane trapping system to allow animals to be tagged for research purposes.

The tasks include the development of proposals for the following:

Task 1 – camera tracking system

Task 2 – sensing control system

Task 3 – trapping system

Task 4 – camera rail

Task 1 – camera tracking system

The TV crew must film an animal as it moves along a path in a forest.

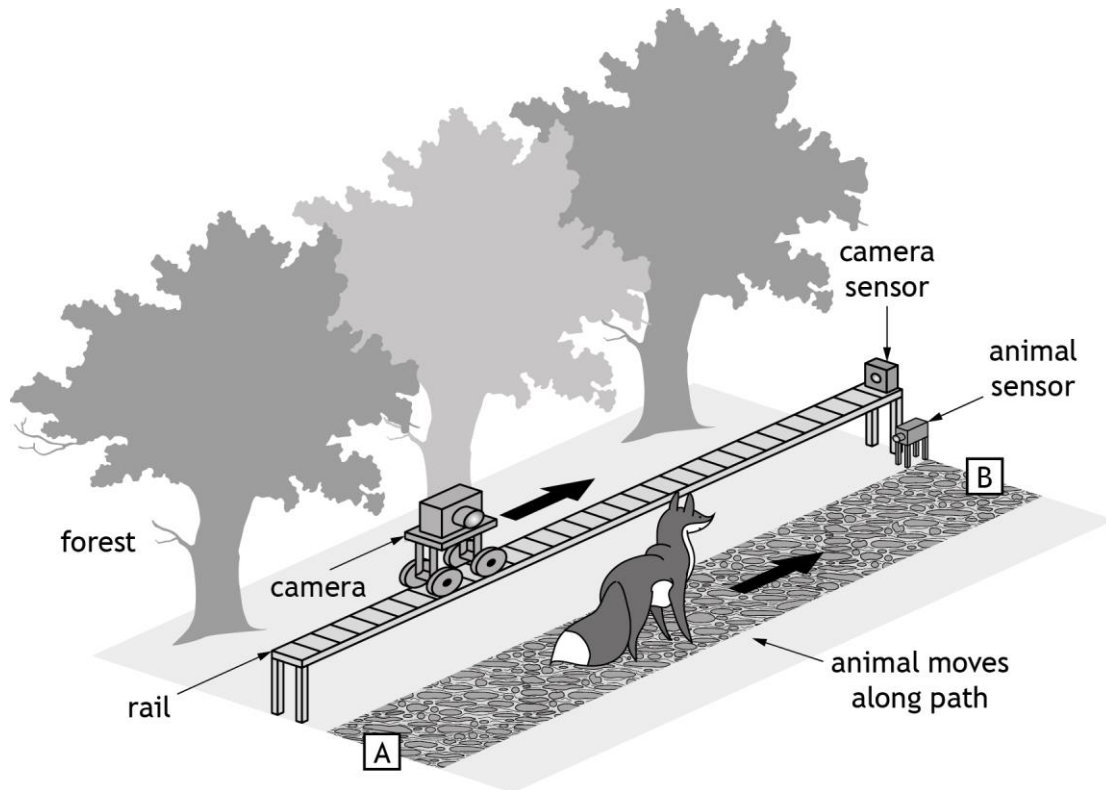

An electronic system is required to control the motion of the camera on a mechanical rail as the animal moves from point A to B.

The animal sensor signals how far the animal is from point 'B'. A camera sensor signals how far the camera is from point 'B'. When there is a difference between the two signals the electronic control system sends an output signal to a motor to move the camera along the rail.

The system must meet the following specification:

- i. When the position of the camera is in line with the animal the electronic control system gives out a 0 V signal.
- ii. When the camera is at point A and the animal is at point B the electronic control system gives out a +2.5 V signal.
- iii. As the two get closer together, the output voltage of the electronic control system decreases.

1a Analyse this specification by completing, on **worksheet 1a**, a control diagram for the electronic control and tracking system.

You must present your evidence on A4 single-sided pages, with the task number clearly labelled.

(6 marks)

The circuit diagram below shows a proposal for part of the electronic control system. The potentiometers represent the animal and camera sensors.

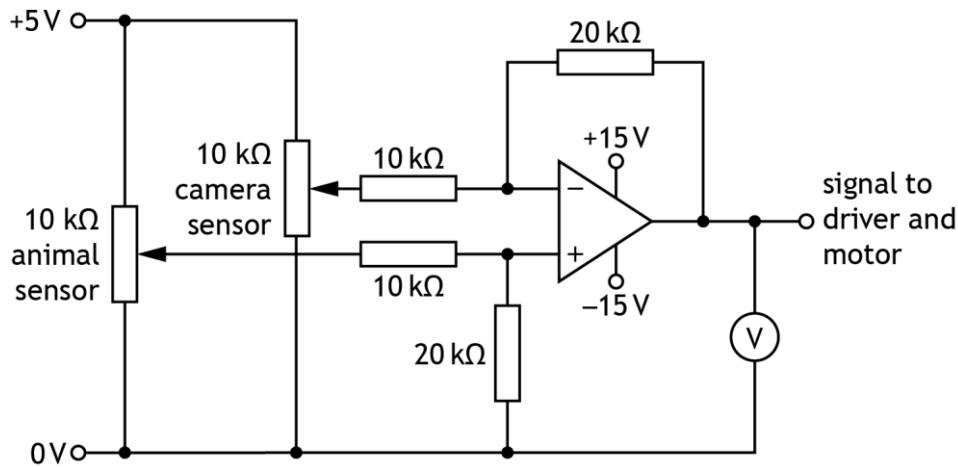

- 1b Simulate or construct this circuit. You must clearly label the camera and animal sensors.

You must present your evidence on A4 single-sided pages, with the task number clearly labelled. Screenshots or images **must be clear and easy to read**.

(2 marks)

The animal sensor must give its highest output when the animal is at point A. The camera sensor must give its highest output when the camera is at point A.

- 1c Complete the testing table on **worksheet 1c** by carrying out the planned tests given in the table. **You should make amendments, as necessary, before moving onto the next test.**

You must write descriptions of the actual results you observed during testing and any appropriate amendments you made to enable the system to meet the specification.

You must present your evidence on A4 single-sided pages, with the task number clearly labelled.

(5 marks)

- 1d Using your results from **task 1c**, simulate or construct your amended circuit. You must clearly label the camera and animal sensors.

You must present your evidence on A4 single-sided pages, with the task number clearly labelled. Screenshots or images **must be clear and easy to read**.

(2 marks)

The output from the circuit must operate a MOSFET driven motor.

- 1e Design, on **worksheet 1e**, a suitable circuit to drive the motor. The circuit must include a motor and a MOSFET.

You must not use simulation software to complete this task.

You must present your evidence on A4 single-sided pages, with the task number clearly labelled.

(2 marks)

Task 2 – sensing control system

To ensure the system is only triggered by the correct type of animal a more complex set of sensors and control is introduced. The following logic diagram describes the conditions that will activate the system:

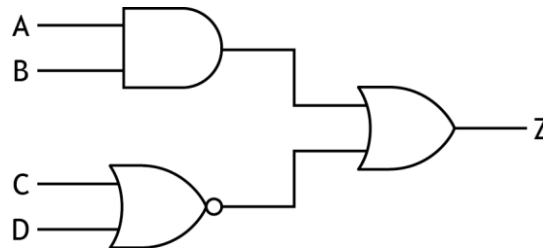

- 2a Simulate or construct this logic circuit. Include suitable input and output devices to allow for testing. **Label all inputs and output.**

You must present your evidence on A4 single-sided pages, with the task number clearly labelled. Screenshots or images **must be clear and easy to read.**

(1 mark)

- 2b Test your circuit from **task 2a** and complete the truth table provided on **worksheet 2** to show the actual results.

You must present your evidence on A4 single-sided pages, with the task number clearly labelled.

(1 mark)

A further design is also being considered which involves programming a microcontroller circuit using the flow chart shown below.

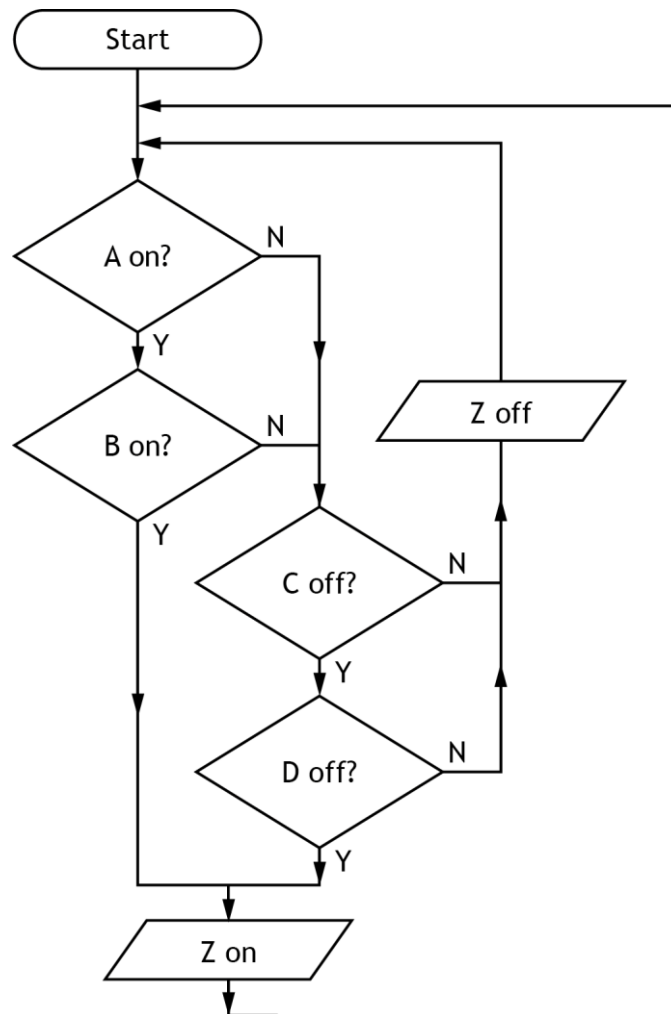

2f i) Evaluate these **three** possible designs (logic circuit, NAND equivalent and microcontroller circuit) in relation to factors such as manufacture, flexibility and cost. You must identify an advantage or disadvantage for each design.

(3 marks)

ii) State which solution would be most suitable in this sensing control system.

You must present your evidence on A4 single-sided pages, with the task number clearly labelled.

(1 mark)

Task 3 – Trapping system

Animals are to be trapped so that they can be tagged with electronic tracking transmitters before being released unharmed. To enable them to do this the following systems will be used.

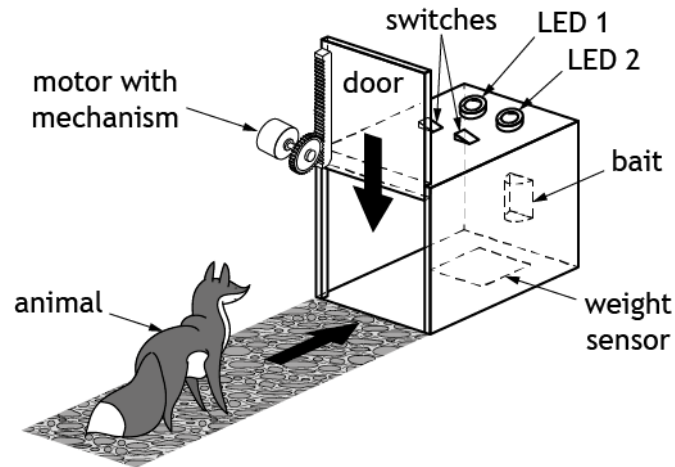

An electronic engineer designed the flowchart and circuit shown as a possible solution.

Input/Output	Pin
Motor on	Output7
Forward (1), backward(0)	Output6
LED 1	Output5
LED 2	Output4
Set switch	Input2
Release switch	Input1
Weight sensor	Analogue input 0

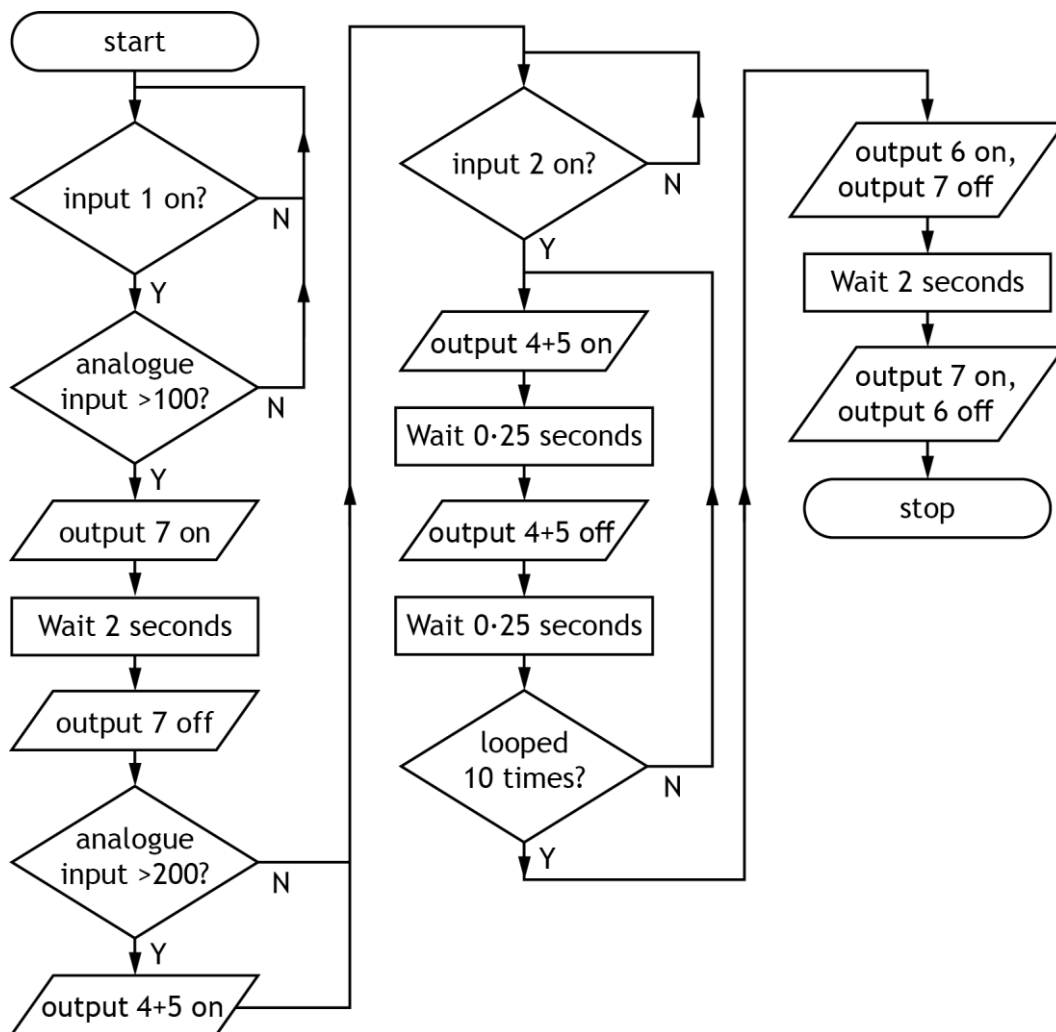
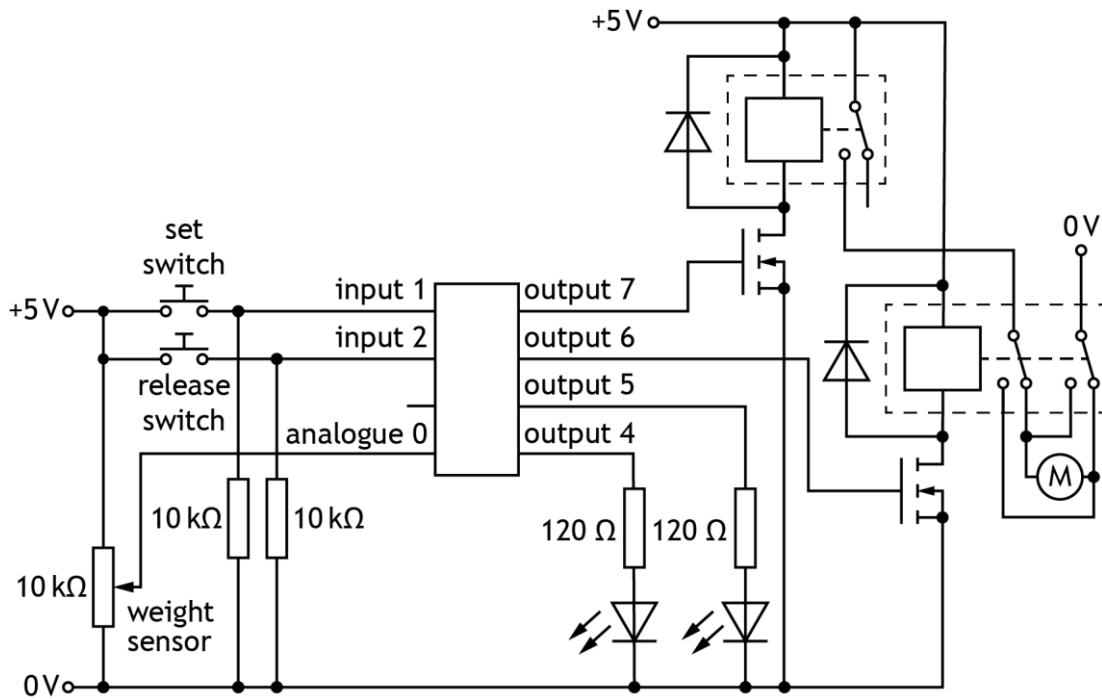

- 3a Simulate or construct the flowchart and electronic circuit **integrated together** as shown.

Note: The analogue values ‘100’ and ‘200’ can be replaced with 2 V and 4 V respectively or other equivalent values depending on the software being used.

You must present your evidence on A4 single-sided pages, with the task number clearly labelled. Screenshots or images **must be clear and easy to read.**

(6 marks)

The trapping system is operated by a microcontroller, and performs to the following specification:

- i. When the trap has been set with bait, the user activates the system with the set switch.
- ii. When a weight sensor rises above 100 the trap door is shut by a motor operated mechanism.
- iii. When the trap door is shut, LED 1 lights to indicate the presence of an animal in the trap.
- iv. If the weight sensor gives a signal greater than 200 then LED 2 must also light.
- v. When the animal has been tagged, the user presses the release switch. Both LEDs then flash 10 times over 5 seconds to give the user time to get clear.
- vi. The trap then opens (by causing the motor to rotate the other way) and the LEDs switch off.
- vii. The process then ends.

Errors were found with the flowchart during testing.

- 3b Test your simulation or construction against the specification and complete the testing table in **worksheet 3b** by carrying out the planned tests given. You should **make amendments, as necessary, before moving onto the next test.**

You must write descriptions of the actual results you observed during testing and any appropriate amendments you made to enable the system to meet the specification.

You must present your evidence on an A4 single-sided page, with the task number clearly labelled.

(6 marks)

- 3c Draw or simulate your **amended flowchart** from **task 3b**.

You must present your evidence on A4 single-sided pages, with the task number clearly labelled. Screenshots or images **must be clear and easy to read.**

(3 marks)

3d Evaluate the performance of your amended flowchart and circuit from **task 3c** against the specification given in **task 3b** by describing:

- ◆ the performance of your amended flowchart to meet each of the specification points
- ◆ two observations on the overall suitability of the system for use with wild animals in an outdoor environment

You must present your evidence on A4 single-sided pages, with the task number clearly labelled.

(6 marks)

Task 4 – camera rail

A diagram of a section of the rail that the camera system moves along is shown below. As the camera starts to move it applies both a vertical and horizontal load to the track.

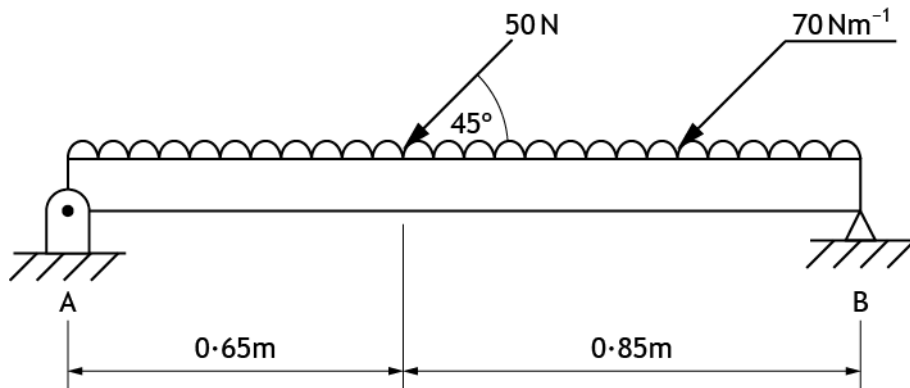

- 4 Simulate this structure to determine the horizontal and vertical reactions at A and B.

You **must** use simulation software for this task.

You must present your evidence on A4 single-sided pages, with the task number clearly labelled. Screenshots or images **must be clear and easy to read.**

(2 marks)

[END OF ASSIGNMENT]

[BLANK PAGE]

DO NOT WRITE ON THIS PAGE



Higher
Coursework
Assessment Task



Higher Engineering Science Assignment Assessment task: wildlife filming

Worksheets

Valid for session 2019-20 only.

Worksheet 1a

animal →

→ movement

(6 marks)

Name:	
Date of birth:	
Scottish Candidate Number (SCN):	
Centre name:	
Centre number:	

Worksheet 1c

Planned test	Expected result	Actual result	Amendments made
Set both inputs to their lowest setting (0 V).	Output on voltmeter should be 0 V.		
Set the animal sensor input to its minimum (0 V) and the camera position sensor to its maximum (5 V).	Output on voltmeter should be +2.5 V.		
Leave the animal sensor at its minimum (0 V) then reduce the camera position sensor gradually from 5 V to 0 V.	Output on voltmeter should reduce from +2.5 V to 0 V.		

(5 marks)

Name:	
Date of birth:	
Scottish Candidate Number (SCN):	
Centre name:	
Centre number:	

Worksheet 1e

Signal from op-amp _____

(2 marks)

Name:	
Date of birth:	
Scottish Candidate Number (SCN):	
Centre name:	
Centre number:	

Worksheet 2 (for use with task 2b and 2d)

A	B	C	D	Z	NAND equivalent
0	0	0	0		
0	0	0	1		
0	0	1	0		
0	0	1	1		
0	1	0	0		
0	1	0	1		
0	1	1	0		
0	1	1	1		
1	0	0	0		
1	0	0	1		
1	0	1	0		
1	0	1	1		
1	1	0	0		
1	1	0	1		
1	1	1	0		
1	1	1	1		

(1 mark)
(1 mark)

Name:	
Date of birth:	
Scottish Candidate Number (SCN):	
Centre name:	
Centre number:	

Worksheet 3b

Planned test	Expected result	Actual result	Amendments
<p>Set analogue input to 0 (lowest value).</p> <p>Press then release 'Set' switch.</p> <p>Adjust weight sensor from 0 to over 100 (2 V), but less than 200 (4 V).</p>	<p>Flow chart progresses through first two decisions, motor turns on for 2 seconds, and LED 1 lights.</p>		
<p>Repeat above test but set weight sensor to 255 (highest value 5 V).</p>	<p>As above but LEDs 1 and 2 will both light.</p>		
<p>When both LEDs are on, press 'Release' switch.</p>	<p>Both LEDs flash 10 times, then the motor rotates in the opposite direction for 2 seconds.</p>		

(6 marks)

Name:	
Date of birth:	
Scottish Candidate Number (SCN):	
Centre name:	
Centre number:	

Administrative information

Published: January 2020 (version 1.0)

History of changes

Version	Description of change	Date

Security and confidentiality

This document can be used by SQA approved centres for the assessment of National Courses and not for any other purpose.

This document may only be downloaded from SQA's designated secure website by authorised personnel.

© Scottish Qualifications Authority 2020