

FOR OFFICIAL USE



National
Qualifications
2019

Mark

X823/76/01

Engineering Science

FRIDAY, 17 MAY

1:00 PM – 3:30 PM



* X 8 2 3 7 6 0 1 *

Fill in these boxes and read what is printed below.

Full name of centre

Town

Forename(s)

Surname

Number of seat

Date of birth

Day

Month

Year

Scottish candidate number

Total marks — 110

SECTION 1 — 20 marks

Attempt ALL questions.

SECTION 2 — 90 marks

Attempt ALL questions.

Show all working and units where appropriate.

You should refer to the Higher Engineering Science Data Booklet which you have been given.

The number of significant figures expressed in a final answer should be equivalent to the least significant data value given in the question. Answers that have two more figures or one less figure than this will be accepted.

Write your answers clearly in the spaces provided in this booklet. Additional space for answers is provided at the end of this booklet. If you use this space you must clearly identify the question number you are attempting.

Use **blue** or **black** ink.

Before leaving the examination room you must give this booklet to the Invigilator; if you do not, you may lose all the marks for this paper.



* X 8 2 3 7 6 0 1 0 1 *

SECTION 1 — 20 marks

Attempt ALL questions

1. An electronic engineer requires the following circuit as part of a hand-held product. It is to be made using individual integrated circuits (ICs).

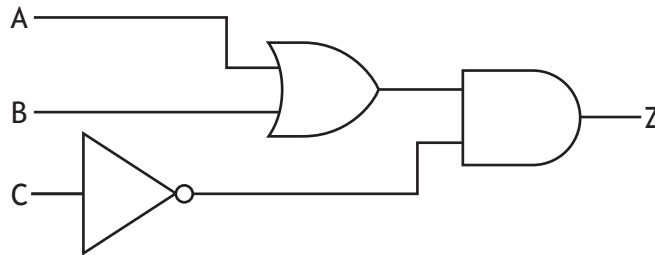

- (a) Draw a NAND equivalent for the circuit shown above.

3

- (b) Explain why the engineer chose to use the NAND equivalent circuit in the product rather than the original circuit.

1



2. A microphone in a recording studio produces a maximum output signal of 2.0 mV.



The following circuit is used to amplify the signal so that it can be recorded.

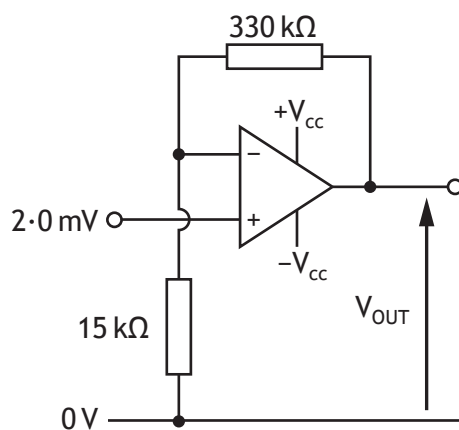

- (a) Calculate the output voltage from the op-amp shown above.

1



2. (continued)

- (b) Describe how the gain of the op-amp circuit could be increased.

1

The mixing desk in the studio needs to combine the signals from a number of microphones and instruments to produce one output signal for the speakers.

- (c) State the op-amp configuration required to perform this task.

1



* X 8 2 3 7 6 0 1 0 4 *

3. A frame structure is shown below.

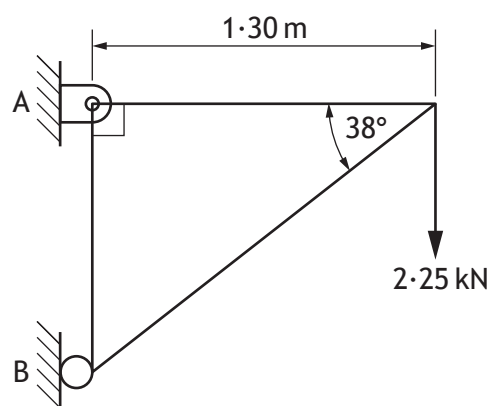

Calculate the magnitude and indicate the direction of the reaction at B.

4



* X 8 2 3 7 6 0 1 0 5 *

4. An air pressure supply system in a car garage will be operated by programmable control. The system must meet the following specification.
- The system is activated when a user presses a start button
 - The pumping system then switches on
 - The air pressure is monitored by an analogue sensor
 - When the air pressure rises above a set level (100), the pump switches off
 - A light must flash five times to indicate that the air pressure has reached the set level
 - The system then resets, ready for the next user

Input	Pin	Output
	7	Pump
	6	Light
Start button	1	
Pressure sensor	0	

Part of the same test program is shown below in **PBASIC** and **ARDUINO** code.

```

let dirs = %11110000
symbol pressure = b4

main: if pin1 = 1 then main
    high 7

check: readadc 0, pressure
if pressure ≤ 200 then check
    low 7

    for b3 = 0 to 5
        high 6
        pause 200
        low 6
        pause 200
    next b3

goto main

```

```

int Pressure = 0;
int Pressuresensor = 0;
int Pump = 7;
int Light = 6;
int Startbutton = 1;

void setup(){
pinMode (Pressuresensor, INPUT);
pinMode (Startbutton, INPUT);
pinMode (Pump, OUTPUT);
pinMode (Light, OUTPUT);
}

void loop(){
if (Startbutton == LOW) {
digitalWrite(Pump, HIGH);
} else {
digitalWrite(Pump, LOW);
}
Pressure = analogRead (Pressuresensor);
if (Pressure <= 200){
digitalWrite (Pump, LOW);
}
for(int counter=0; counter<=5;
counter=counter+1)
{digitalWrite(Light, HIGH);
delay(200);
digitalWrite(Light, LOW);
delay(200);
}
}
}

```



* X 8 2 3 7 6 0 1 0 6 *

4. (continued)

There are three faults in the program shown opposite.
Identify the lines where the faults are and write the corrected code.
Complete for either PBASIC or ARDUINO.

2

The first fault is shown below.

Correction 1 PBASIC *main: if pin1 = 0 then main*

Correction 1 ARDUINO *if (Startbutton == HIGH) {*

Correction 2

Correction 3

[Turn over



* X 8 2 3 7 6 0 1 0 7 *

5. A concurrent force system is shown below.

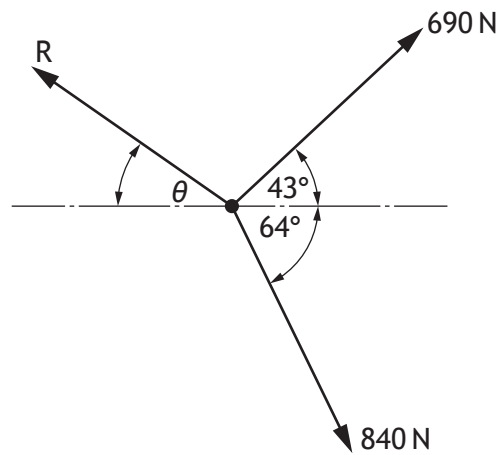

Calculate the magnitude and angle of the force R required to maintain equilibrium.

4



* X 8 2 3 7 6 0 1 0 8 *

6. The temperature in a room can be set by a signal from a mobile phone or directly using a control panel.

A heating system monitors the temperature of the room and maintains the set temperature.

Complete the control diagram below for the heating of the room.

3

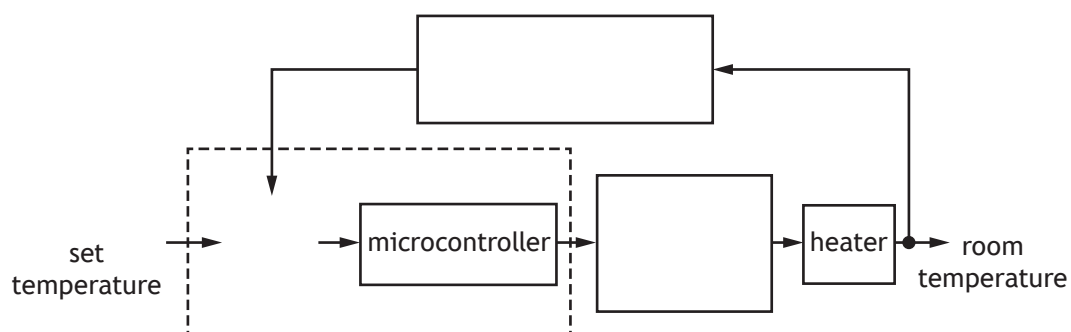

[Turn over



* X 8 2 3 7 6 0 1 0 9 *

7. A prototype of an electrically powered aeroplane is being developed and tested by a team of engineers.

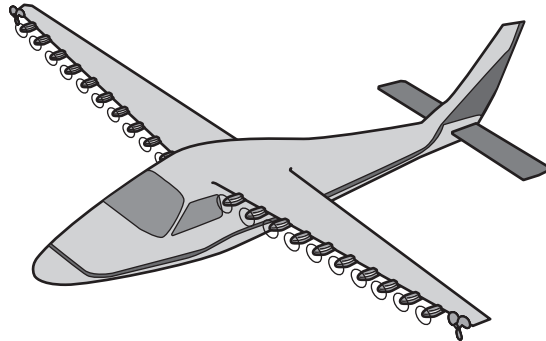

The aeroplane is powered by 22 motor-driven propellers that each supply 18 kW.

- (a) Calculate the rotational speed of each motor if it produces 23 Nm of torque.

1

When operating at full power the aeroplane is 73% efficient. The aeroplane's battery stores 320 MJ when fully charged.

- (b) Calculate how much time the aeroplane can run at full power before the battery runs out.

2



7. (continued)

MARKS
DO NOT
WRITE IN
THIS
MARGIN

Improving efficiency is a key task for the engineers who design the aeroplane.

- (c) Explain **one** economic and **one** social impact of improving the efficiency of the aeroplane.

2

Economic _____

Social _____

When the aeroplane lands, the propellers are used to transform its kinetic energy back into electrical energy to recharge the batteries as part of a regenerative braking system.

The combined mass of the aeroplane and passengers is 4800 kg and the regenerative braking system is 64% efficient.

- (d) Calculate the energy recovered if the aeroplane's velocity changes from 95 m s^{-1} to 25 m s^{-1} .

3

[Turn over



* X 8 2 3 7 6 0 1 1 1 *

7. (continued)

The pilot controls the speed of the aeroplane by moving an accelerator lever. A signal is sent from the lever to a microcontroller which, in turn, sends a signal to an op-amp circuit and the motors' drive systems.

The op-amp circuit is shown below. Each pin from the microcontroller gives a 5.0V signal when on.

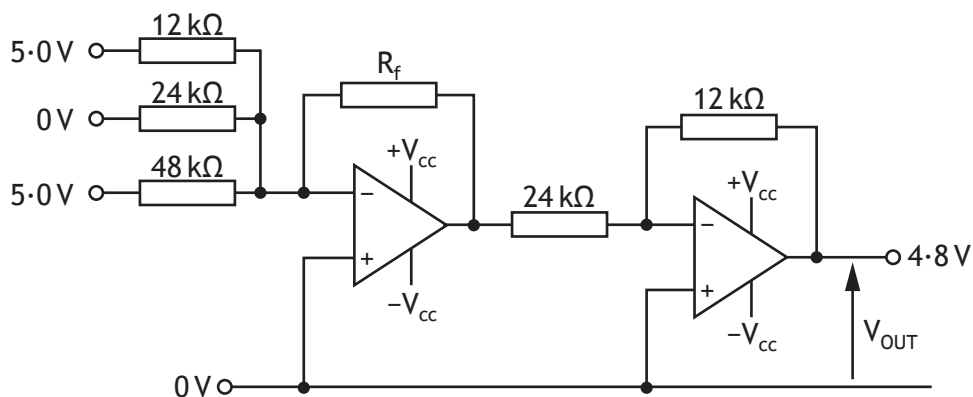

(f) Calculate the value of the feedback resistor, R_f , when V_{OUT} is 4.8V.

3



8. An exercise bike has an electronic monitoring system to tell users if they are pedalling within a set range of speeds.



A speed sensor produces an output voltage, V_{speed} , in proportion to the speed of the pedals.

If the voltage is below the lower limit, a bank of LEDs lights to say, 'SPEED UP'.

If the voltage is above the higher limit, a second bank of LEDs lights to say, 'TAKE IT EASY'.

The control circuit is shown below.

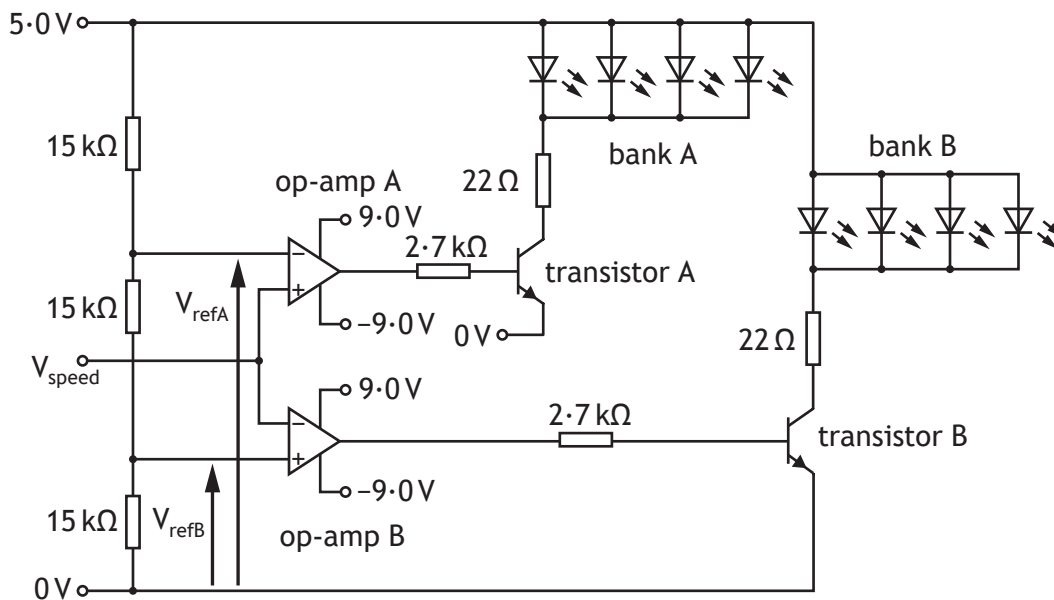

* X 8 2 3 7 6 0 1 1 4 *

8. (continued)

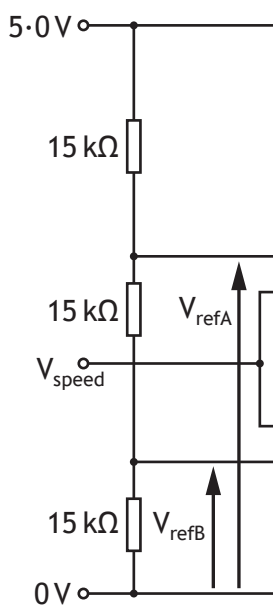

A section of the circuit is shown above.

(a) Calculate the reference voltage V_{refA} .

2

[Turn over



8. (continued)

A section of the circuit is shown.

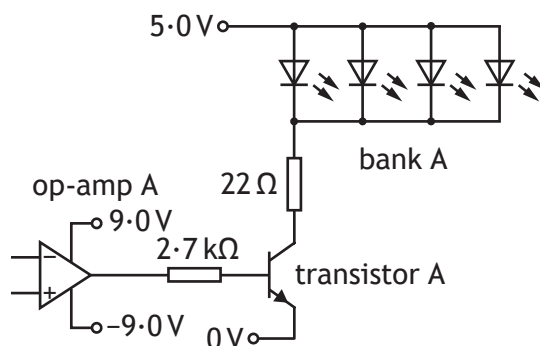

- (b) (i) Calculate the base current for transistor A when op-amp A is saturated positive. (Assume V_{be} is 0.70 V).

3

Transistor A has a gain (h_{FE}) of 140.

- (ii) Calculate the collector current when op-amp A is saturated.

1



[Turn over for next question

DO NOT WRITE ON THIS PAGE



* X 8 2 3 7 6 0 1 1 9 *

9. A team of engineers is asked to design a walkway over a dinosaur exhibit for a natural history museum.



An initial design for a walkway over the top of the exhibit is shown below.

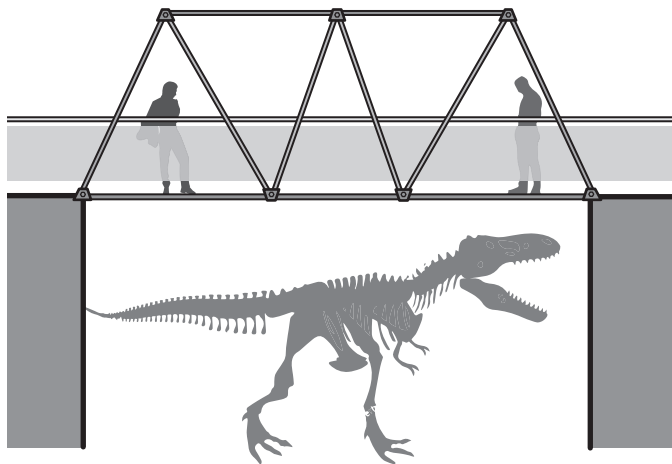

* X 8 2 3 7 6 0 1 2 0 *

9. (continued)

A partially completed free body diagram of the design for the walkway is shown.

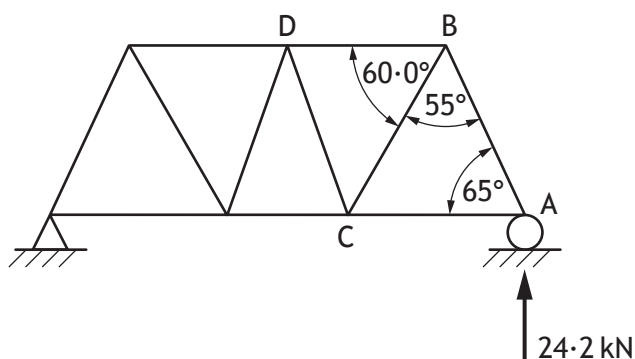

- (b) Calculate, using nodal analysis, the magnitude and nature of the forces in members AB, AC, BC and BD.

Complete the table below.

7

Show all working and final units on the page opposite.

Member	Magnitude	Nature
AB		STRUT
AC		TIE
BC		
BD		



9. (b) (continued)

Space for working



* X 8 2 3 7 6 0 1 2 3 *

10. A mechanical engineer produced a preliminary design for a pneumatic system to open and close a dinosaur skeleton's jaw.



The pneumatic cylinder used to move the jaw has an 8.0 mm diameter aluminium alloy piston rod to support a load of 33.2 kN.

- (a) (i) Calculate the factor of safety applied to the design of the piston rod.

4



10. (a) (continued)

- (ii) Comment on the appropriateness of the factor of safety of the piston rod.

1

The mechanical engineer decides to use a different pneumatic cylinder to support the 33.2 kN load.

The piston rod area is 491 mm² and is made from **titanium alloy** with a length of 0.78 m.

- (iii) Calculate the change of length in the piston rod under these conditions.

4



* X 8 2 3 7 6 0 1 2 5 *

10. (continued)

After testing, the pneumatic cylinder is repositioned to move a hinged beam in the jaw of the dinosaur as shown below.

The uniformly distributed load of the jaw is 48.4 kN m^{-1} .

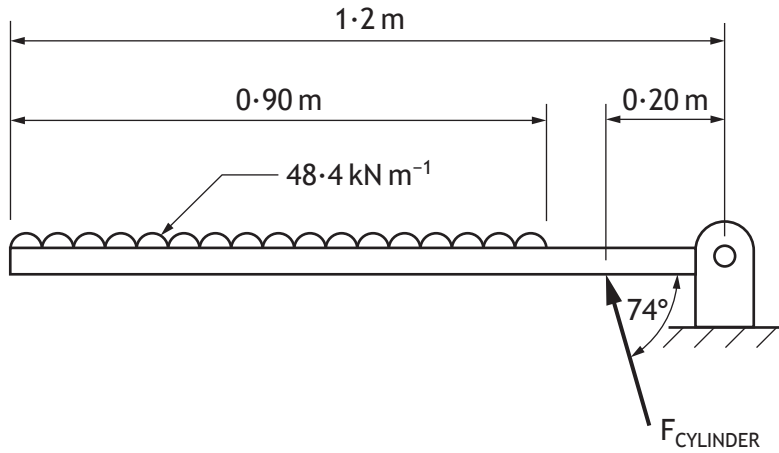

(b) (i) Calculate the magnitude of force F_{CYLINDER} .

3

(ii) Calculate the magnitude and direction of the reaction at the hinge.

4



[Turn over for next question

DO NOT WRITE ON THIS PAGE



* X 8 2 3 7 6 0 1 2 7 *

11.



MARKS

DO NOT
WRITE IN
THIS
MARGIN

A proposed design for the operation of a conveyor belt motor has the following specification.

1. The motor will not run if emergency stop(A) is high
2. The motor will run if a pressure sensor(B) is high and a light sensor(C) is low
3. The motor will run if a test switch(D) is high

(a) Complete the Boolean equation for when the motor switches on.

4

M =

When the conveyor belt motor starts it uses pulse width modulation to accelerate to a set speed.

The control sequence for the acceleration of the conveyor belt motor has the following steps.

- Initially the MARK = 4 and the SPACE = 2
- Each new pulse increases the MARK by 1
- The acceleration continues until the MARK reaches 20
- The motor turns on
- The motor will then stop when the emergency stop is high or the override switch is low
- A brake engages for 3 seconds
- The sequence repeats

INPUT	PIN	OUTPUT
	7	motor
	6	brake
override switch (released = 0)	1	
emergency stop (pressed = 1)	0	



* X 8 2 3 7 6 0 1 2 8 *

11. (continued)

(b) Complete, with reference to the specification and input/output table shown opposite, the flowchart for the control of the motor.

13

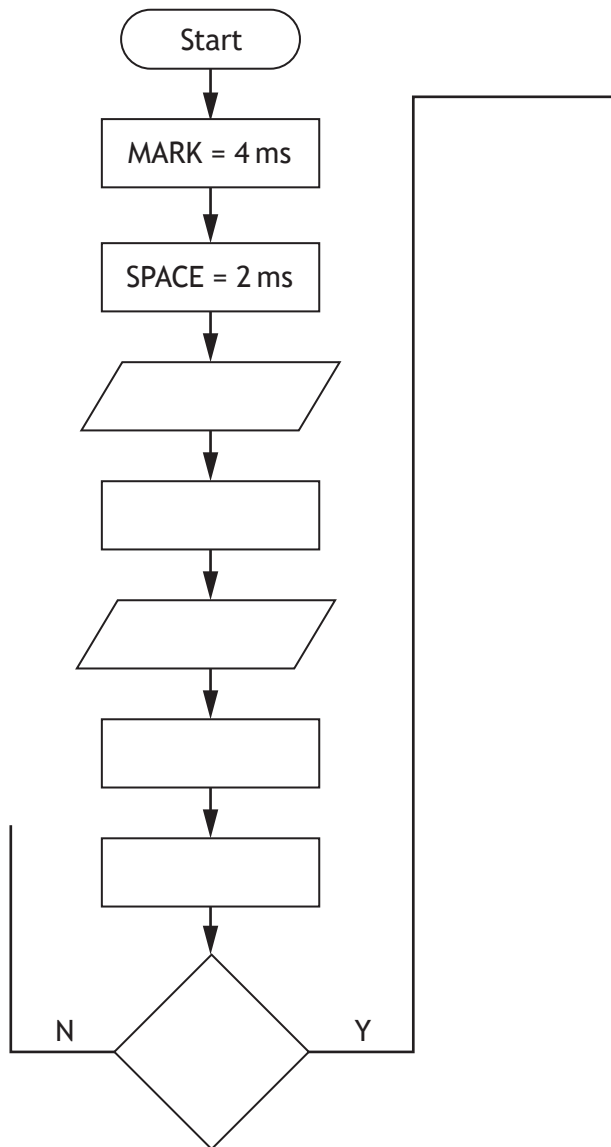

12. A pneumatic system will be used in a manufacturing process for holding material in place and then moving it along the production line. The system diagram is shown below.

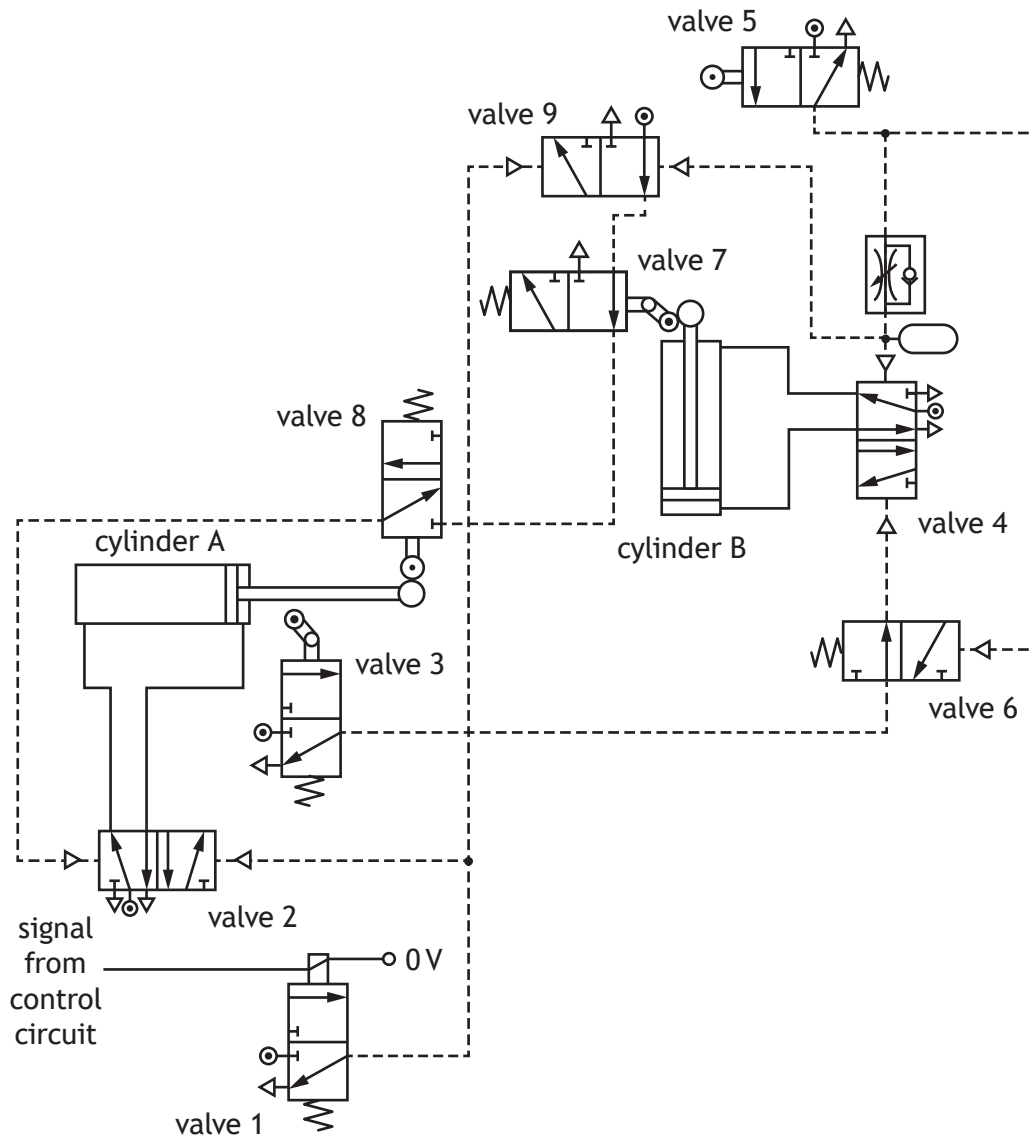

- (a) Describe, making reference to the diagram above, the operation of the pneumatic circuit.

7

When valve 1 is actuated,



* X 8 2 3 7 6 0 1 3 0 *

12. (continued)

DO NOT
WRITE IN
THIS
MARGIN

A diagram of the control circuit for the solenoid is shown below. The MOSFET switches on when the gate voltage reaches 3.2V. This happens when the thermistor is at 85°C.

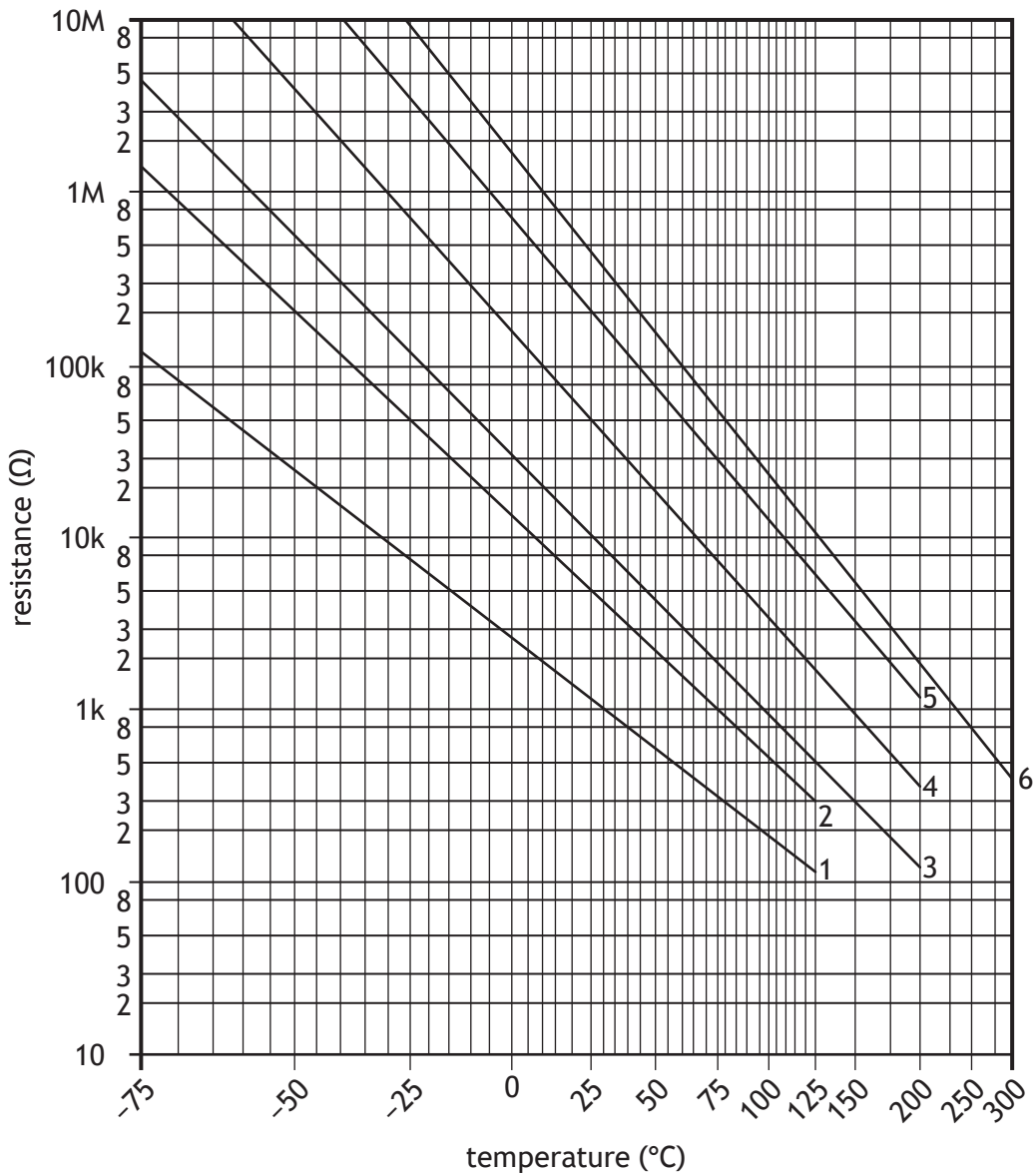
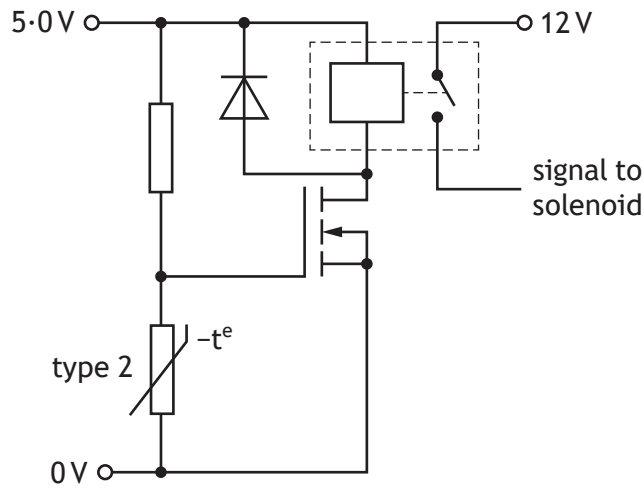

12. (continued)

MARKS

DO NOT
WRITE IN
THIS
MARGIN

- (b) Calculate, with reference to the graph opposite, the resistance of the fixed resistor to produce a gate voltage of 3.2 V.

3

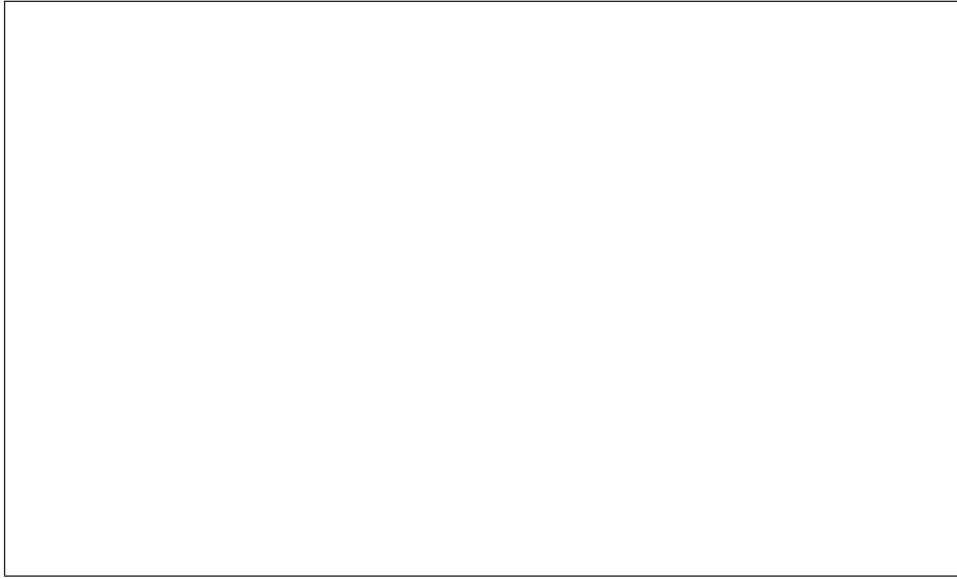

The next stage of the manufacturing process requires a drive system.

- (c) Describe one skill and one piece of knowledge a **mechanical engineer** requires to design the drive system.

2

Skill _____

Knowledge _____

[Turn over



* X 8 2 3 7 6 0 1 3 3 *

12. (continued)

Part of the design involves rotary motion, from a motor, transforming into linear motion.

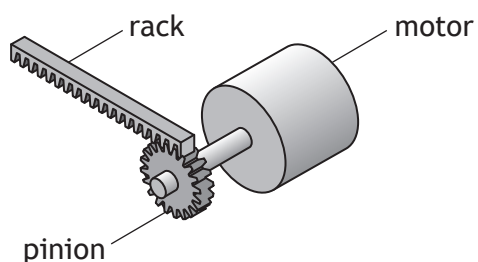

The pinion gear has 24 teeth and the pitch of the teeth on the rack is 3.0 mm. The rack is required to move 2.75 m in three seconds.

(d) Calculate the required speed of the motor.

3



12. (continued)

Part of the circuit controlling the motor is shown below.

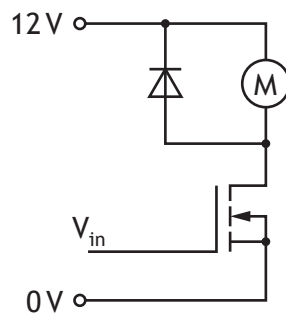

The motor has a **rating** of 12 V and 8.5 W.

When the motor is switched on the MOSFET has a resistance of 0.65Ω .

(e) Calculate the MOSFET drain current.

3

[END OF QUESTION PAPER]



* X 8 2 3 7 6 0 1 3 5 *

MARKS

DO NOT
WRITE IN
THIS
MARGIN

ADDITIONAL SPACE FOR ANSWERS



* X 8 2 3 7 6 0 1 3 6 *

MARKS

DO NOT
WRITE IN
THIS
MARGIN

ADDITIONAL SPACE FOR ANSWERS



* X 8 2 3 7 6 0 1 3 7 *

[BLANK PAGE]

DO NOT WRITE ON THIS PAGE



* X 8 2 3 7 6 0 1 3 8 *

[BLANK PAGE]

DO NOT WRITE ON THIS PAGE



* X 8 2 3 7 6 0 1 3 9 *

[BLANK PAGE]

DO NOT WRITE ON THIS PAGE

Acknowledgement of copyright

- | | |
|-------------|-------------------------------------|
| Question 2 | TZIDO SUN/shutterstock.com |
| Question 8 | Julian Rovagnati/shutterstock.com |
| Question 9 | Clari Massimiliano/shutterstock.com |
| Question 10 | Marques/shutterstock.com |
| Question 11 | Vivi-o/shutterstock.com |



* X 8 2 3 7 6 0 1 4 0 *