

FOR OFFICIAL USE



National  
Qualifications  
2018

Mark

**X723/76/01**

**Engineering Science**

THURSDAY, 24 MAY

1:00 PM – 3:00 PM



\* X 7 2 3 7 6 0 1 \*

Fill in these boxes and read what is printed below.

Full name of centre

Town

Forename(s)

Surname

Number of seat

Date of birth

Day

Month

Year

Scottish candidate number

**Total marks — 90**

**SECTION 1 — 20 marks**

Attempt ALL questions.

**SECTION 2 — 70 marks**

Attempt ALL questions.

**Show all working and units where appropriate.**

The number of significant figures expressed in a final answer should be equivalent to the least significant data value given in the question. Answers that have two more figures or one less figure than this will be accepted.

Reference may be made to the Engineering Science Higher Data Booklet.

Write your answers clearly in the spaces provided in this booklet. Additional space for answers is provided at the end of this booklet. If you use this space you must clearly identify the question number you are attempting.

Use **blue** or **black** ink.

Before leaving the examination room you must give this booklet to the Invigilator; if you do not, you may lose all the marks for this paper.



\* X 7 2 3 7 6 0 1 0 1 \*

SECTION 1 — 20 marks

Attempt ALL questions

MARKS

DO NOT  
WRITE IN  
THIS  
MARGIN

1. A mechanical engineer completes a tensile test on a material to identify its properties. A graph of the results is shown.

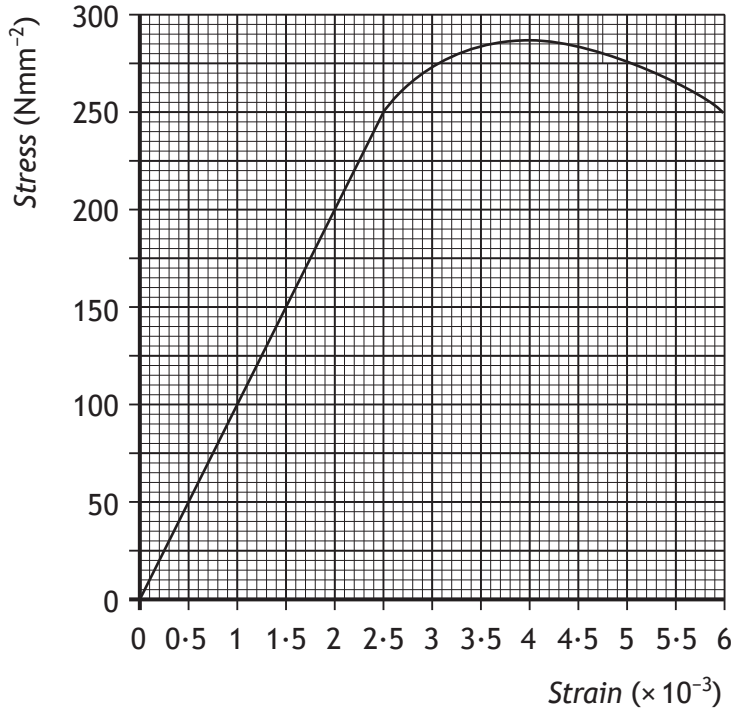

- (a) (i) Calculate, with reference to the graph, the value of Young's Modulus. 2

A second material was tested by the engineer. It was found to have a higher value of Young's Modulus.

- (ii) Draw on the graph above, a line that illustrates this property. 1

During the original test it was found that the test piece stretched 0.225 mm when a load of 11.8 kN was applied.

- (b) Calculate the strain energy stored in the material. 1



\* X 7 2 3 7 6 0 1 0 2 \*

2. A concurrent force system in equilibrium is shown below.

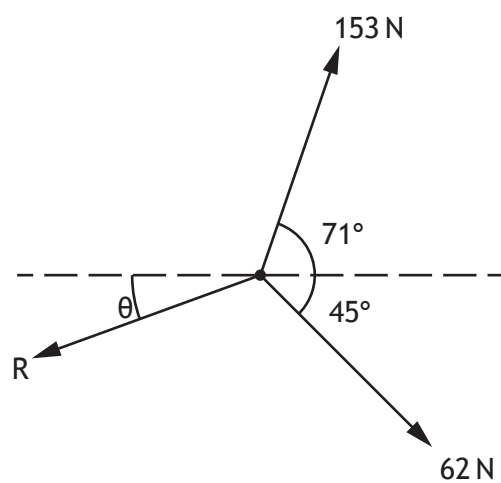

Calculate the magnitude of the force R.

3



\* X 7 2 3 7 6 0 1 0 3 \*

3. The engineer responsible for the structural design of a large metal sculpture chose to use alloy steel for the inner support structure, and stainless steel for the cladding.

Describe two examples of specialist skills and two examples of specialist knowledge that a structural engineer would use.

4

Skill 1 \_\_\_\_\_

\_\_\_\_\_

\_\_\_\_\_

\_\_\_\_\_

Skill 2 \_\_\_\_\_

\_\_\_\_\_

\_\_\_\_\_

\_\_\_\_\_

Knowledge 1 \_\_\_\_\_

\_\_\_\_\_

\_\_\_\_\_

\_\_\_\_\_

Knowledge 2 \_\_\_\_\_

\_\_\_\_\_

\_\_\_\_\_

\_\_\_\_\_



\* X 7 2 3 7 6 0 1 0 4 \*

4. A lighting gantry is held in place with two supports.

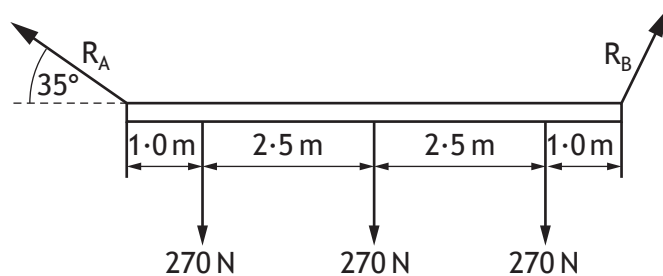

(a) Calculate, by taking moments, the reaction force,  $R_A$ .

3

LED and Organic LED based lights are replacing traditional filament lamps.

(b) Describe an economic and an environmental impact of this technology.

2

Economic \_\_\_\_\_

\_\_\_\_\_

\_\_\_\_\_

Environmental \_\_\_\_\_

\_\_\_\_\_

\_\_\_\_\_

[Turn over



5. Two driver circuits are being considered for a temperature indicator system to be used with an electric iron. As the temperature rises the casing of the iron is illuminated by an internal lamp.

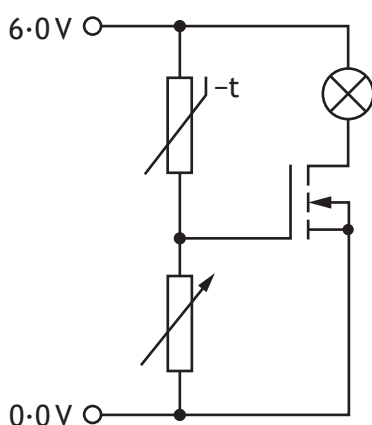

Circuit A

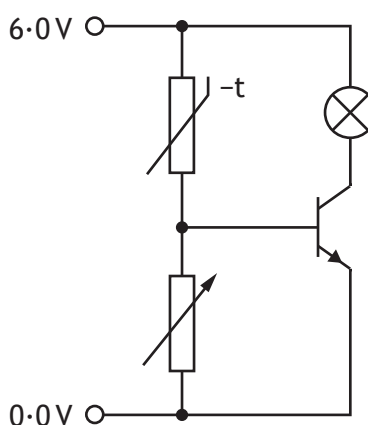

Circuit B

In circuit A, a change in temperature produces a change in the **gate voltage**. This affects the size of the current through the lamp.

- (a) Describe how the current through the lamp in circuit B is controlled.

1

---



---



5. (continued)

MARKS

DO NOT  
WRITE IN  
THIS  
MARGIN

The characteristics of circuit A are shown below.

Gate voltage ( $V_{GS}$ )	Current ( $I_{DS}$ )
5.0 V	240 mA
4.0 V	154 mA
3.6 V	86.4 mA
3.2 V	38.4 mA
3.0 V	21.6 mA

When testing circuit A, it was found that  $V_{DS}$  was 4.27 V when the thermistor resistance was 3.2 k $\Omega$ .

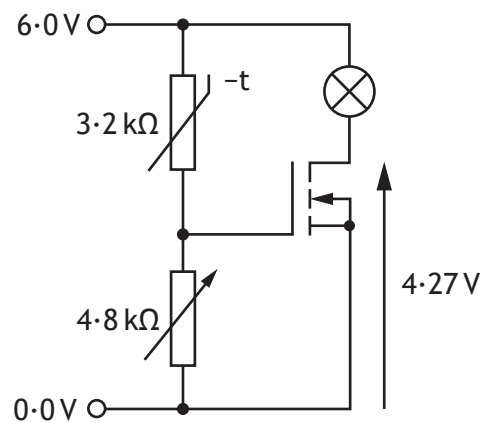

Circuit A

(b) Calculate the resistance of the lamp.

3



\* X 7 2 3 7 6 0 1 0 7 \*

SECTION 2 — 70 marks

Attempt ALL questions

DO NOT  
WRITE IN  
THIS  
MARGIN

6. A new rollercoaster has been designed for a theme park. The ride has two queues: one for groups, who wait behind a barrier, and the second for single riders, who wait behind a gate.

The system counts how many people get on the carriage as they pass the sensor.

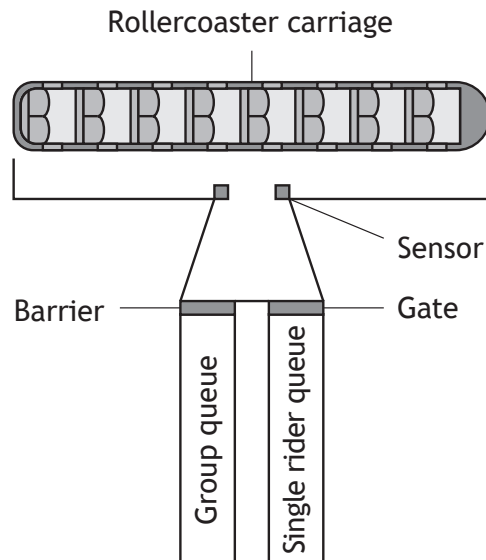

INPUT	PIN	OUTPUT
	7	Barrier (open = high)
	6	Gate (open = high)
	5	Motor
	4	
Launch Switch	3	
Start Switch	2	
Single Rider Switch	1	
Sensor	0	

The control sequence for the rollercoaster has the following steps.

- An operator presses a start switch to begin the boarding process.
- The barrier will open to allow up to 16 people from the group queue to take a seat.
- The sensor will give a high signal each time a person passes through, allowing the number of people to be counted.
- If the carriage is not filled from the group queue, a single rider switch is pressed by the operator.
- The barrier should then close and the gate should open to allow single riders on to occupy all remaining seats.
- Once riders are seated the operator presses a launch switch which closes the gate and the motor is then on for 30 seconds.
- The system should loop.



6. (continued)

(a) Draw a flowchart to show how the ride is operated.

9

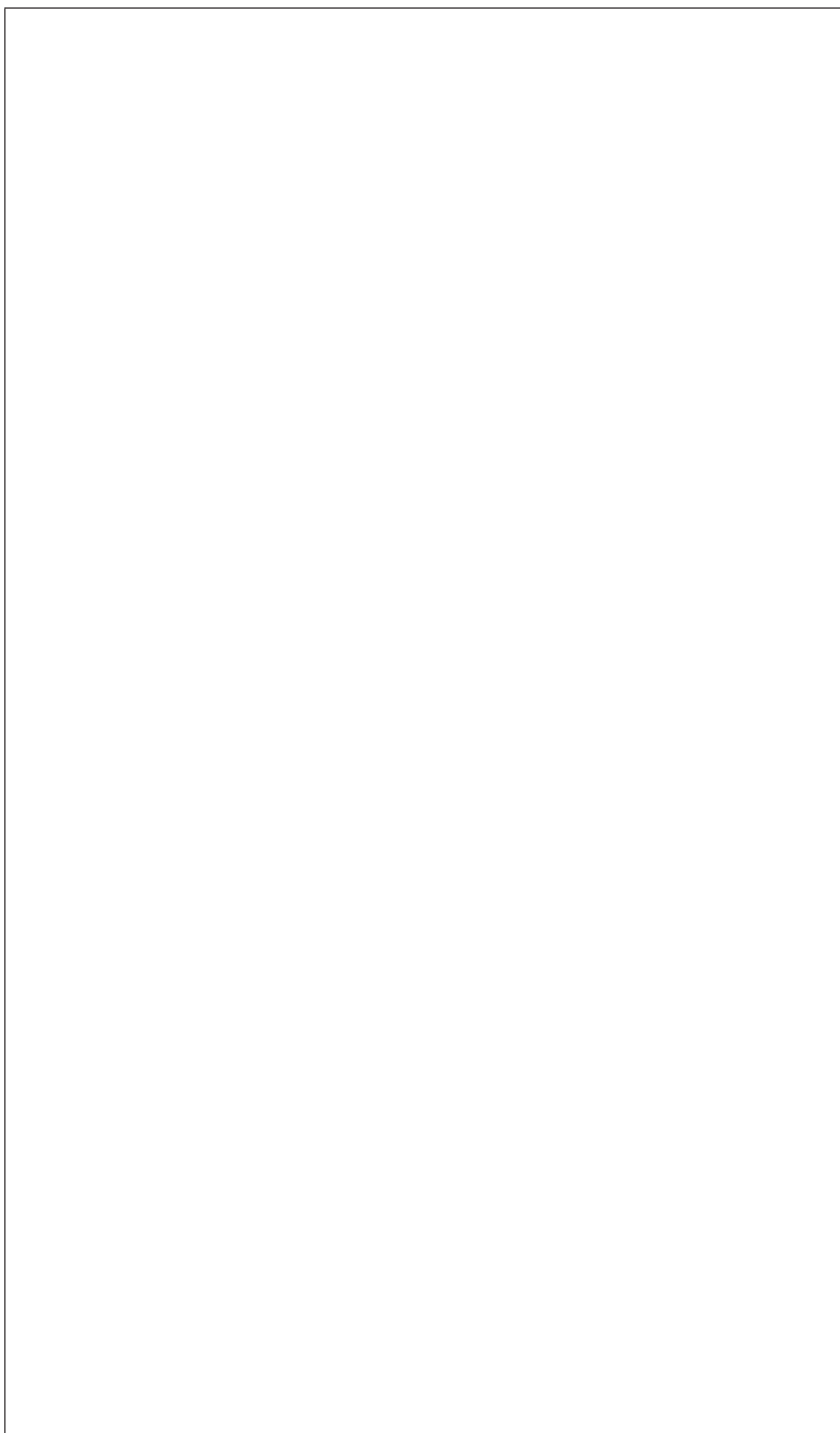

\* X 7 2 3 7 6 0 1 0 9 \*

6. (continued)

MARKS

DO NOT  
WRITE IN  
THIS  
MARGIN

The platform where people board the carriage can be lifted up to gain access to the track for maintenance.

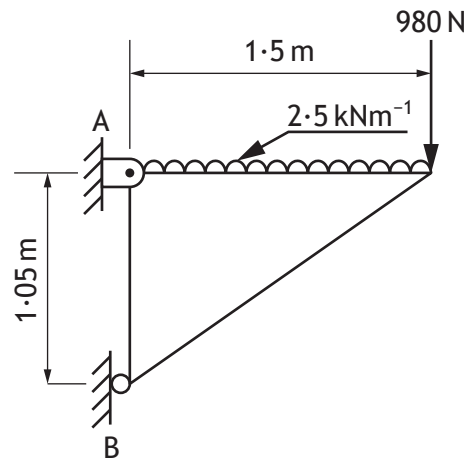

(b) Calculate the magnitude and direction of the reaction at node A.

5



6. (continued)

MARKS

DO NOT  
WRITE IN  
THIS  
MARGIN

The ride has a safety system in place to prevent it from operating in unsafe weather conditions. The logic diagram shows a part of that system.

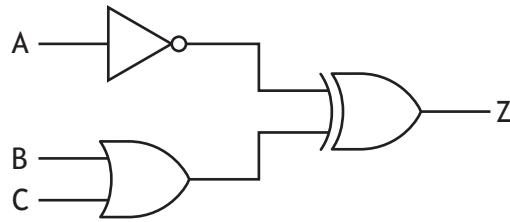

(c) Complete the Boolean equation for the logic diagram.

3

Z = \_\_\_\_\_

(d) Draw a NAND equivalent for the logic diagram.

3

[Turn over



\* X 7 2 3 7 6 0 1 1 1 \*

7. A team of mechanical engineers are working together to design a new car.

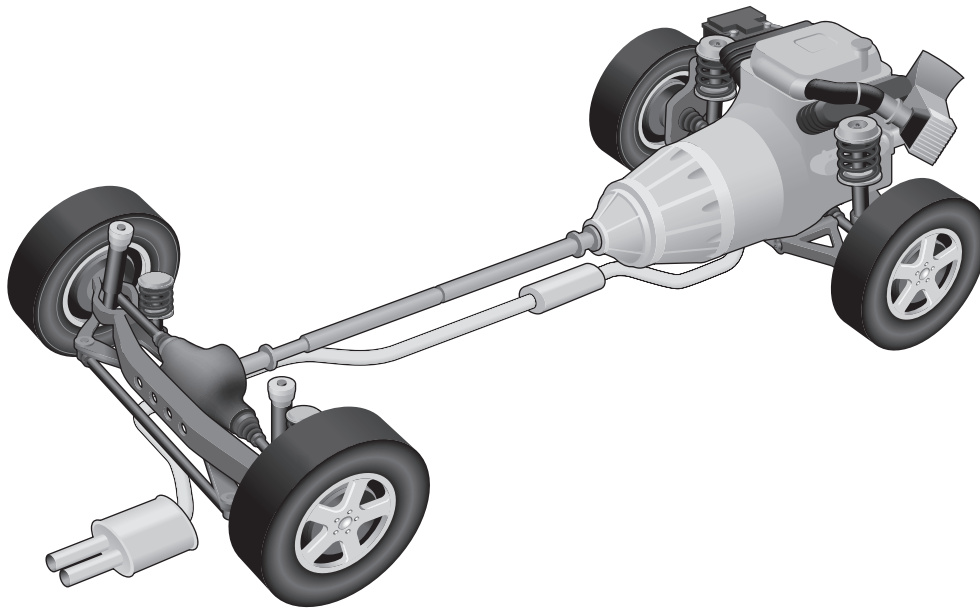

The use of couplings features in the design of the drive shaft.

(a) Explain why couplings are used in the design.

2

---



---



---



---



\* X 7 2 3 7 6 0 1 1 2 \*

7. (continued)

One of the key features in the car is a cruise control system.

A control diagram for the cruise control system is shown below.

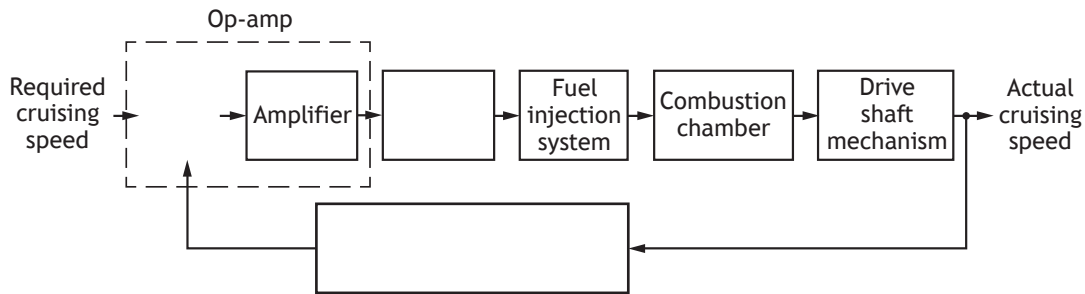

(b) Complete the diagram.

3

The car is also designed with air conditioning.

(c) Describe how proportional control is used to maintain a steady temperature.

You may wish to use annotated diagrams to support your answer.

3



7. (continued)

MARKS  
DO NOT  
WRITE IN  
THIS  
MARGIN

Kinetic Energy Recovery System (KERS) is an emerging technology that the engineers wish to use in the new car.

When the car is braking, KERS uses a flywheel to store energy from the brakes. This can be transferred back to the wheels when activated by the driver. This will boost acceleration to a higher velocity for a short period of time.

The flywheel rotates at  $64500 \text{ revs min}^{-1}$  and provides  $18 \text{ Nm}$  of torque. The system output was measured at  $112.4 \text{ kW}$  of power.

(d) Calculate the efficiency of the KERS system.

3



7. (continued)

MARKS  
DO NOT  
WRITE IN  
THIS  
MARGIN

The car's mass is 2100 kg. During a road test the driver activated the KERS system while travelling at  $31 \text{ ms}^{-1}$ . This transferred an additional 390 kJ of energy which increased the velocity of the car.

The driver used the brakes to stop the car. Once at rest, the brake discs had a temperature of  $249 \text{ }^\circ\text{C}$ . The temperature prior to braking was  $23 \text{ }^\circ\text{C}$ .

The car's brake discs have a specific heat capacity of  $420 \text{ J kg}^{-1} \text{ K}^{-1}$ .

(e) Calculate the mass of the car's brake discs.

4

(Assume all of the car's kinetic energy is converted to heat)

[Turn over



\* X 7 2 3 7 6 0 1 1 5 \*

8. The Kelpies, part of The Helix park, were built on industrial wasteland as part of a regeneration project. The park has extensive children's play facilities, cycling paths, a water sports centre and has improved the local canal for its users.

Industrial wasteland



The Kelpies, The Helix



\* X 7 2 3 7 6 0 1 1 6 \*

## 8. (continued)

(a) Since the park opened, the local population has enjoyed many benefits.

- (i) Describe two social benefits brought to the area as a result of this project.

2

Benefit 1 \_\_\_\_\_

\_\_\_\_\_

\_\_\_\_\_

Benefit 2 \_\_\_\_\_

\_\_\_\_\_

\_\_\_\_\_

- (ii) Describe two roles that an environmental engineer would have during the **construction phase** of a regeneration project.

2

Role 1 \_\_\_\_\_

\_\_\_\_\_

\_\_\_\_\_

Role 2 \_\_\_\_\_

\_\_\_\_\_

\_\_\_\_\_

[Turn over



\* X 7 2 3 7 6 0 1 1 7 \*

8. (continued)

MARKS

DO NOT  
WRITE IN  
THIS  
MARGIN

During the design phase a structural engineering company produced detailed information about the internal structure of the Kelpies.

Detail from a proposed design for one of the Kelpies' steel support legs is shown.

Node N1 is in static equilibrium.

M2 is a strut.

- (b) Calculate, using simultaneous equations, the magnitude of the forces in members M1 and M2, and state the nature of the internal force acting on M1.

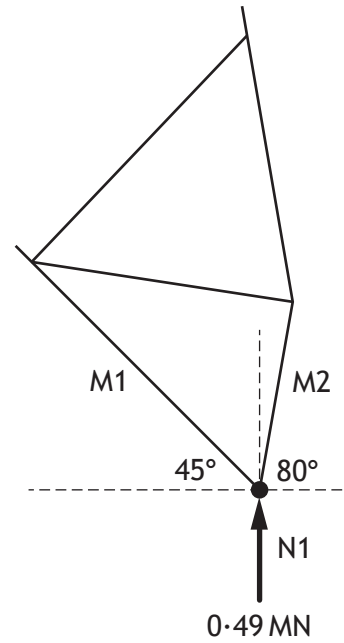

5



\* X 7 2 3 7 6 0 1 1 8 \*

8. (continued)

MARKS  
DO NOT  
WRITE IN  
THIS  
MARGIN

During construction, two sections of the structure were secured using six mild steel bolts as shown below. The total load applied to the bolts is 210 kN.

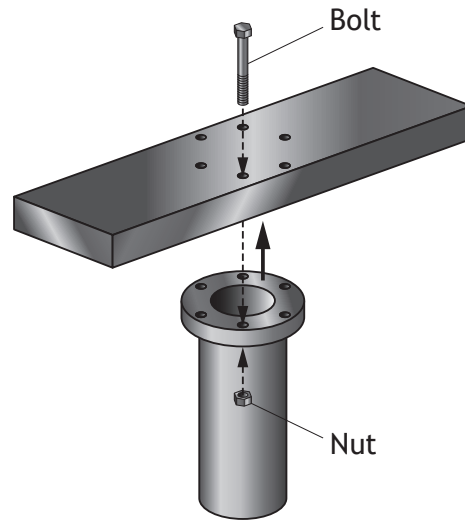

Each bolt has a factor of safety of 4.0 and an original length of 55 mm.

(c) (i) Calculate the required diameter of each bolt.

4

Blank area for the student's answer.



MARKS

DO NOT  
WRITE IN  
THIS  
MARGIN

8. (c) (continued)

(ii) Calculate the change in length of each bolt when loaded.

2



\* X 7 2 3 7 6 0 1 2 0 \*



9. (continued)

- (b) Explain the effect that pressing **both** valves (A) and (B) together would have on the outstroking speed of the cylinder.

2

---

---

---

---

---

---



\* X 7 2 3 7 6 0 1 2 2 \*

9. (continued)

To improve the system, it was decided to automate it further. The materials being used were found to absorb different amounts of light so an electronic control system was introduced to respond to varying light levels.

Valves (A) and (B) were replaced with 3/2 solenoid spring return valves which were to be actuated by the following circuit.

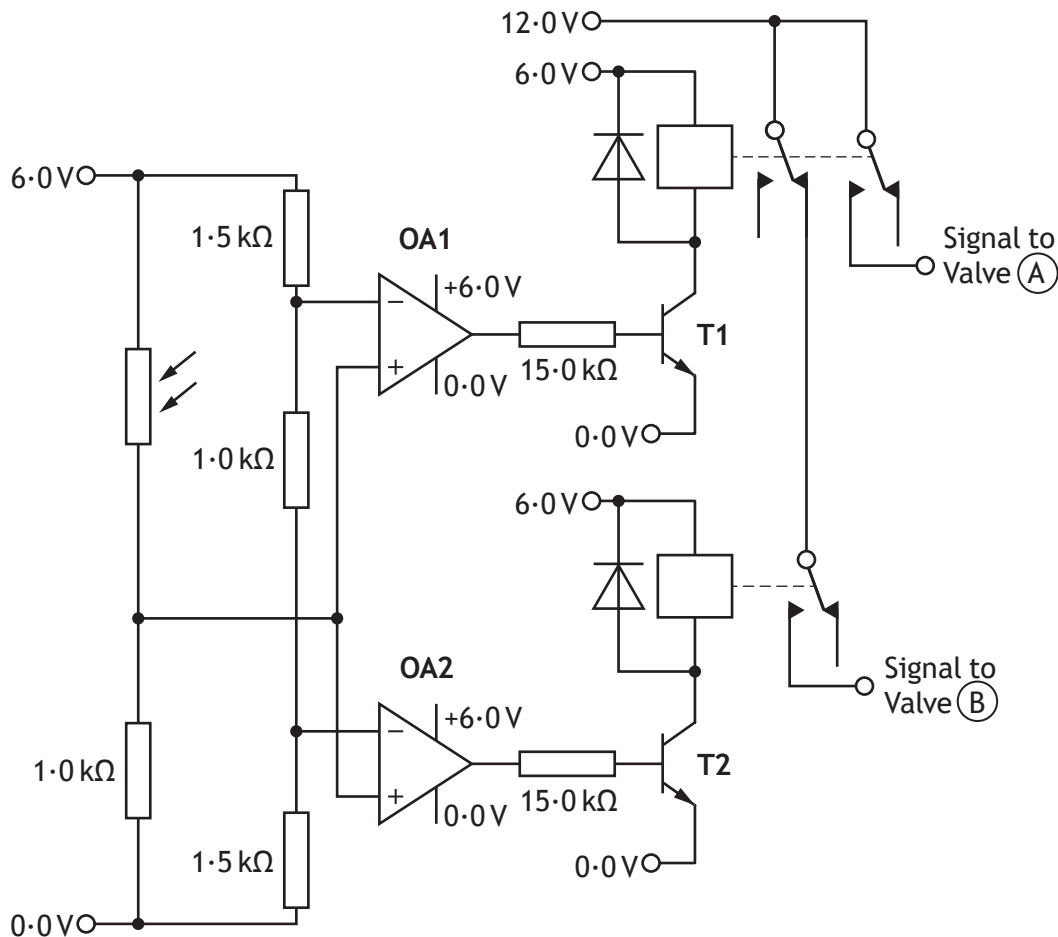

(c) Calculate the base current to transistor T1 when op-amp OA1 is saturated positively.

3



\* X 7 2 3 7 6 0 1 2 3 \*

9. (continued)

MARKS DO NOT WRITE IN THIS MARGIN

Each relay requires a current of 25 mA to switch on.

(d) Calculate the required current gain of transistor T1.

1

The following graph shows the characteristics of the LDR used in the circuit.

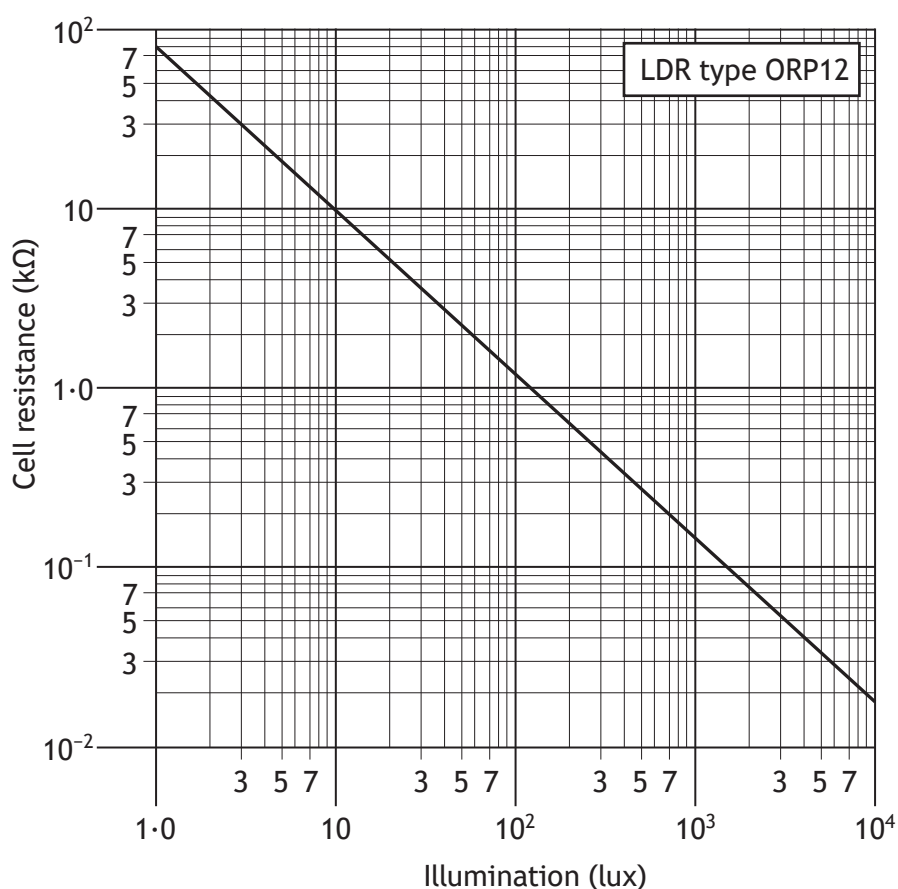

(e) Calculate, with reference to the graph, the light level at which OA1 saturates positively.

2



## 9. (continued)

- (f) Describe, with reference to the circuit, the effect that an increasing light level has **on the transistors**. (Assume that light level is initially low)

3

---

---

---

---

---

---

---

---

- (g) Explain, with reference to the circuit, why only one solenoid can be actuated at a time.

2

---

---

---

[END OF QUESTION PAPER]



\* X 7 2 3 7 6 0 1 2 5 \*

MARKS

DO NOT  
WRITE IN  
THIS  
MARGIN

ADDITIONAL SPACE FOR ANSWERS



\* X 7 2 3 7 6 0 1 2 6 \*

MARKS

DO NOT  
WRITE IN  
THIS  
MARGIN

ADDITIONAL SPACE FOR ANSWERS



\* X 7 2 3 7 6 0 1 2 7 \*

ACKNOWLEDGEMENTS

Question 5 – ruxstockphoto/Shutterstock.com

Question 7 – phil Holmes/Shutterstock.com

Question 8 – Martin Janca/Shutterstock.com  
Helioscribe/Shutterstock.com



\* X 7 2 3 7 6 0 1 2 8 \*