



National  
Qualifications  
2024

---

# 2024 Applications of Mathematics

## Higher

### Question Paper Finalised Marking Instructions

© Scottish Qualifications Authority 2024

These marking instructions have been prepared by examination teams for use by SQA appointed markers when marking external course assessments.

The information in this document may be reproduced in support of SQA qualifications only on a non-commercial basis. If it is reproduced, SQA must be clearly acknowledged as the source. If it is to be reproduced for any other purpose, written permission must be obtained from [permissions@sqa.org.uk](mailto:permissions@sqa.org.uk).



## General marking principles for Higher Applications of Mathematics

*Always apply these general principles. Use them in conjunction with the detailed marking instructions, which identify the key features required in candidates' responses.*

*For each question, the marking instructions are generally in two sections:*

*generic scheme – this indicates why each mark is awarded*

*illustrative scheme – this covers methods which are commonly seen throughout the marking*

*In general, you should use the illustrative scheme. Only use the generic scheme where a candidate has used a method not covered in the illustrative scheme.*

- (a) Always use positive marking. This means candidates accumulate marks for the demonstration of relevant skills, knowledge and understanding; marks are not deducted for errors or omissions.
- (b) If you are uncertain how to assess a specific candidate response because it is not covered by the general marking principles or the detailed marking instructions, you must seek guidance from your team leader.
- (c) One mark is available for each •. There are no half marks.
- (d) If a candidate's response contains an error, all working subsequent to this error must still be marked. Only award marks if the level of difficulty in their working is similar to the level of difficulty in the illustrative scheme.
- (e) Only award full marks where the solution contains appropriate working. A correct answer with no working receives no mark, unless specifically mentioned in the marking instructions.
- (f) Candidates may use any mathematically correct method to answer questions, except in cases where a particular method is specified or excluded.
- (g) If an error is trivial, casual or insignificant, for example  $6 \times 6 = 12$ , candidates lose the opportunity to gain a mark, except for instances such as the second example in point (h) below.

- (h) If a candidate makes a transcription error (question paper to script or within script), they lose the opportunity to gain the next process mark, for example

This is a transcription error and so the mark is not awarded.

$$x^2 + 5x + 7 = 9x + 4$$

This is no longer a solution of a quadratic equation, so the mark is not awarded.

$$x - 4x + 3 = 0$$

$$x = 1$$

The following example is an exception to the above

This error is not treated as a transcription error, as the candidate deals with the intended quadratic equation. The candidate has been given the benefit of the doubt and all marks awarded.

$$x^2 + 5x + 7 = 9x + 4$$

$$x - 4x + 3 = 0$$

$$(x - 3)(x - 1) = 0$$

$$x = 1 \text{ or } 3$$

(i) **Horizontal/vertical marking**

If a question results in two pairs of solutions, apply the following technique, but only if indicated in the detailed marking instructions for the question.

Example:

$$\begin{array}{cc} \bullet^5 & \bullet^6 \\ \bullet^5 & x = 2 \quad x = -4 \\ \bullet^6 & y = 5 \quad y = -7 \end{array}$$

Horizontal:  $\bullet^5 x = 2 \text{ and } x = -4$       Vertical:  $\bullet^5 x = 2 \text{ and } y = 5$   
 $\bullet^6 y = 5 \text{ and } y = -7$                        $\bullet^6 x = -4 \text{ and } y = -7$

You must choose whichever method benefits the candidate, **not** a combination of both.

- (j) In final answers, candidates should simplify numerical values as far as possible unless specifically mentioned in the detailed marking instruction. For example

$$\frac{15}{12} \text{ must be simplified to } \frac{5}{4} \text{ or } 1\frac{1}{4} \qquad \frac{43}{1} \text{ must be simplified to } 43$$

$$\frac{15}{0.3} \text{ must be simplified to } 50 \qquad \frac{4}{\cancel{5}}/3 \text{ must be simplified to } \frac{4}{15}$$

$$\sqrt{64} \text{ must be simplified to } 8^*$$

\*The square root of perfect squares up to and including 144 must be known.

- (k) Commonly Observed Responses (COR) are shown in the marking instructions to help mark common and/or non-routine solutions. CORs may also be used as a guide when marking similar non-routine candidate responses.
- (l) Do not penalise candidates for any of the following, unless specifically mentioned in the detailed marking instructions:
- working subsequent to a correct answer
  - correct working in the wrong part of a question
  - legitimate variations in numerical answers/algebraic expressions, for example angles in degrees rounded to nearest degree
  - omission of units
  - bad form (bad form only becomes bad form if subsequent working is correct), for example

$(x^3 + 2x^2 + 3x + 2)(2x + 1)$  written as

$$(x^3 + 2x^2 + 3x + 2) \times 2x + 1$$

$$= 2x^4 + 5x^3 + 8x^2 + 7x + 2$$

gains full credit

- repeated error within a question, but not between questions or papers
- (m) In any ‘Show that...’ question, where candidates have to arrive at a required result, the last mark is not awarded as a follow-through from a previous error, unless specified in the detailed marking instructions.
- (n) You must check all working carefully, even where a fundamental misunderstanding is apparent early in a candidate’s response. You may still be able to award marks later in the question so you must refer continually to the marking instructions. The appearance of the correct answer does not necessarily indicate that you can award all the available marks to a candidate.
- (o) You should mark legible scored-out working that has not been replaced. However, if the scored-out working has been replaced, you must only mark the replacement working.
- (p) If candidates make multiple attempts using the same strategy and do not identify their final answer, mark all attempts and award the lowest mark. If candidates try different valid strategies, apply the above rule to attempts within each strategy and then award the highest mark.

For example:

Strategy 1 attempt 1 is worth 3 marks.	Strategy 2 attempt 1 is worth 1 mark.
Strategy 1 attempt 2 is worth 4 marks.	Strategy 2 attempt 2 is worth 5 marks.
From the attempts using strategy 1, the resultant mark would be 3.	From the attempts using strategy 2, the resultant mark would be 1.

In this case, award 3 marks.

### Marking Instructions for each question

Question			Generic scheme	Illustrative scheme	Max mark
1.	(a)		• <sup>1</sup> calculate monthly effective rate of interest	• <sup>1</sup> 2.20...(%)	1
<b>Notes:</b> 1. For 2.49...(%). award 0/1 2. For 0.022... award 1/1 3. For 0.022...%. award 0/1					
<b>Commonly Observed Responses:</b>					

Question		Generic scheme	Illustrative scheme	Max mark
1.	(b)	<ul style="list-style-type: none"> <li>•<sup>2</sup> calculate loan outstanding at end of month 1</li> <li>•<sup>3</sup> calculate loan outstanding at end of month 2</li> </ul>	<ul style="list-style-type: none"> <li>•<sup>2</sup> (£) 3838.16</li> <li>•<sup>3</sup> (£) 3672.75</li> </ul>	2

**Notes:**

1. Based on candidate using 2.20...%.

Time (months)	Repayment (£)	Interest content of repayment (£)	Capital content of repayment (£)	Loan outstanding (£)
0				4000.00
1	250.00	88.16	161.84	3838.16
2	250.00	84.59	165.41	3672.75

2. If the interest content of repayment and capital content of repayment are the same in months 1 and 2 then •<sup>3</sup> is unavailable.

3. Accept any valid rounding or truncation.

**Commonly Observed Responses:**

**Candidate A**

Based on candidate using 2.2%

Time (months)	Repayment (£)	Interest content of repayment (£)	Capital content of repayment (£)	Loan outstanding (£)
0				4000.00
1	250.00	88.00	162.00	3838.00
2	250.00	84.44	165.56	3672.44

•<sup>2</sup> ✓

•<sup>3</sup> ✓

**Candidate B**

Based on candidate using 2.49%

Time (months)	Repayment (£)	Interest content of repayment (£)	Capital content of repayment (£)	Loan outstanding (£)
0				4000.00
1	250.00	99.60	150.40	3849.60
2	250.00	95.86	154.14	3695.46

•<sup>2</sup> ✓<sub>1</sub>

•<sup>3</sup> ✓<sub>1</sub>

Question		Generic scheme	Illustrative scheme	Max mark
2.	(a)	<ul style="list-style-type: none"> <li>•<sup>1</sup> interpret first four bullet points</li> <li>•<sup>2</sup> interpret bullet points 5 to 7</li> <li>•<sup>3</sup> complete Venn diagram</li> </ul>	<ul style="list-style-type: none"> <li>•<sup>1</sup> 31 placed where the 3 circles overlap; 34, 7 and 13 placed correctly</li> <li>•<sup>2</sup> 20, 29 and 32 placed appropriately</li> <li>•<sup>3</sup> remaining value completed</li> </ul>	3

**Notes:**

1.

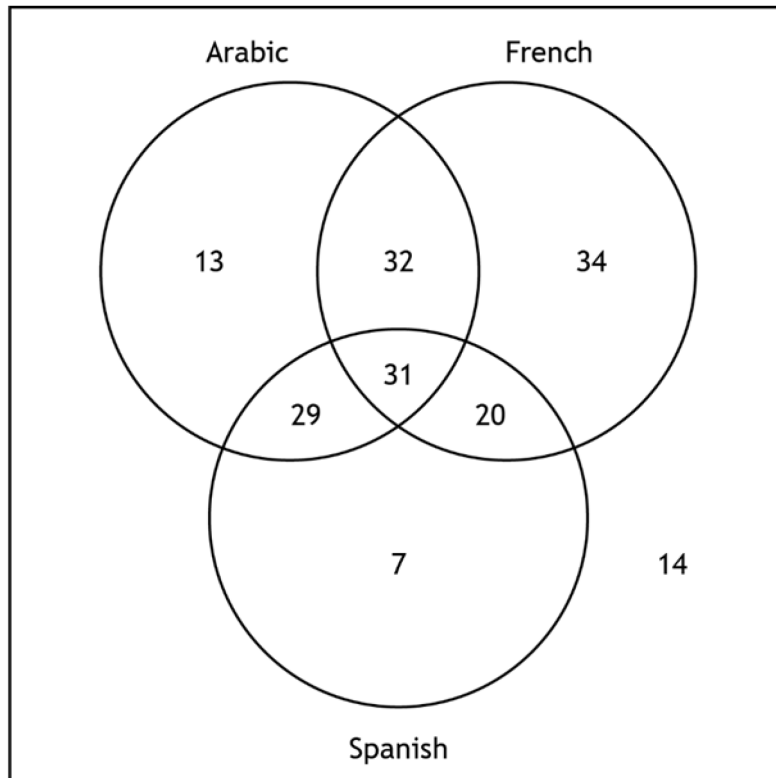

2. The number 14 must be within the diagram.

**Commonly Observed Responses:**

Question		Generic scheme	Illustrative scheme	Max mark
2.	(b)	<ul style="list-style-type: none"> <li>•<sup>4</sup> determine total number of students</li> <li>•<sup>5</sup> determine probability</li> </ul>	<ul style="list-style-type: none"> <li>•<sup>4</sup> 180</li> <li>•<sup>5</sup> <math>\frac{29}{180}</math></li> </ul>	2

**Notes:**

1. Where candidates do not calculate the correct total number of students •<sup>4</sup> is not awarded but •<sup>5</sup> is still available eg  $\frac{29}{166}$  award ~~x~~✓<sub>1</sub>

**Commonly Observed Responses:**

**Candidate A**

For an answer in (a) of

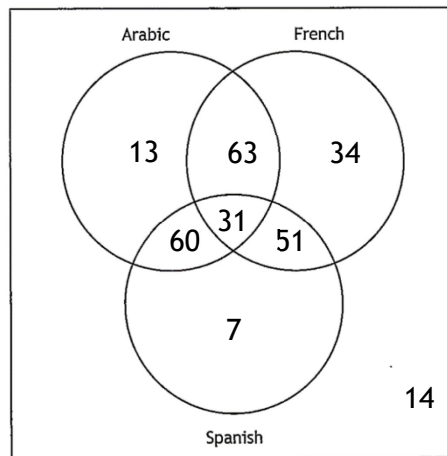

leading to  $\frac{60}{273}$

award ✓<sub>1</sub>✓<sub>1</sub>

Question		Generic scheme	Illustrative scheme	Max mark
3.	(a)	<ul style="list-style-type: none"> <li>•<sup>1</sup> tasks and durations in correct sequence</li> <li>•<sup>2</sup> forward scan A-E correct</li> <li>•<sup>3</sup> forward scan for remaining 5 consistent with previous working</li> <li>•<sup>4</sup> backward scan I, J, H, F and G correct</li> <li>•<sup>5</sup> backward scan for remaining 5 consistent with previous working</li> </ul>	<ul style="list-style-type: none"> <li>•<sup>1</sup> see note 1</li> <li>•<sup>2</sup> see note 2</li> <li>•<sup>3</sup> see note 2</li> <li>•<sup>4</sup> see note 3</li> <li>•<sup>5</sup> see note 3</li> </ul>	5

Question	Generic scheme	Illustrative scheme	Max mark
----------	----------------	---------------------	----------

3. (a) (continued)

Notes:

1. Completed Pert Chart

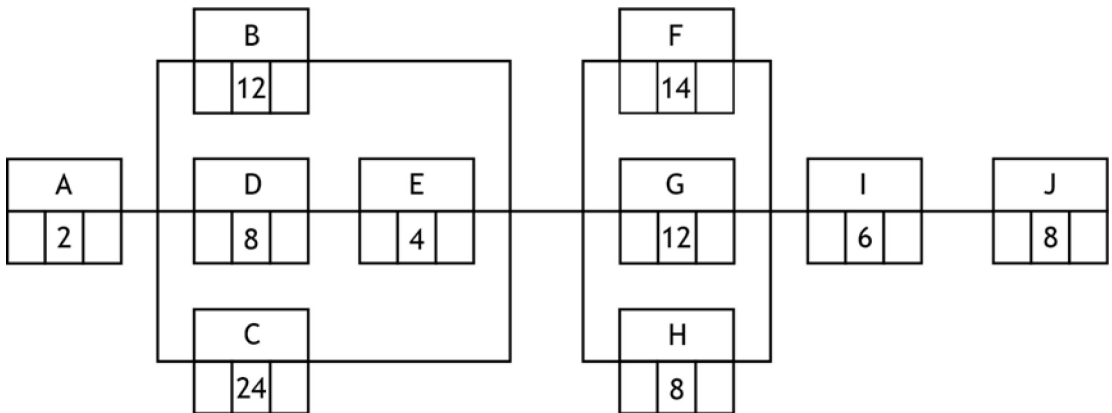

2. Forward Scan

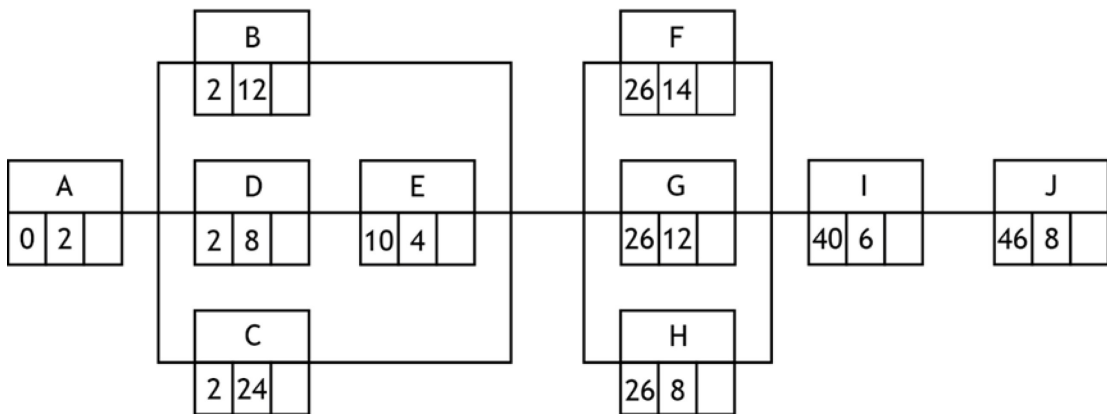

3. Backward Scan

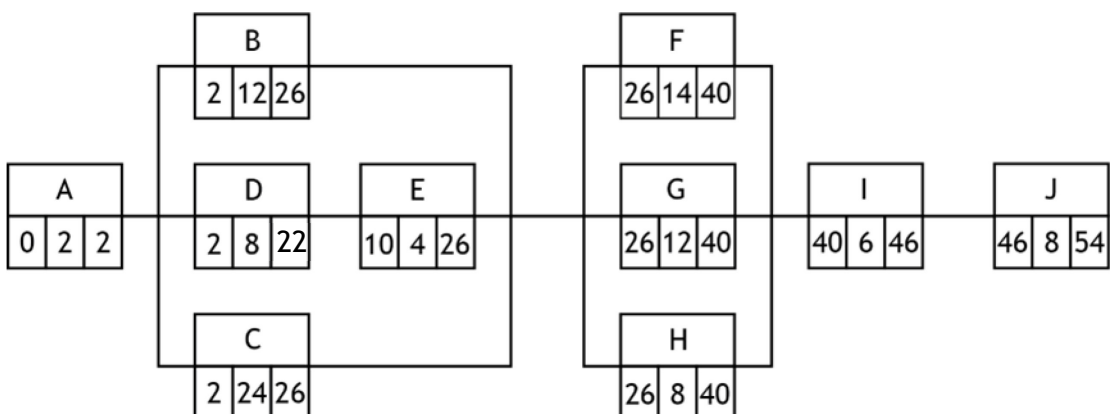

4. Ensure B, C and D are checked carefully for the backward scan.
5. Ensure that D follows on from E in the backward scan.
6. If forward scan is incorrect, care needs to be taken to check the backward scan.

Commonly Observed Responses:

Question		Generic scheme	Illustrative scheme	Max mark
3.	(b)	<ul style="list-style-type: none"> <li>•<sup>6</sup> add task labels and plot tasks A to D</li> <li>•<sup>7</sup> interpret start times of tasks F, I and J</li> <li>•<sup>8</sup> complete Gantt chart</li> </ul>	<ul style="list-style-type: none"> <li>•<sup>6</sup> see diagram note 1</li> <li>•<sup>7</sup> see diagram note 1</li> <li>•<sup>8</sup> see diagram note 1</li> </ul>	3

**Notes:**

1. Completed Gantt chart.

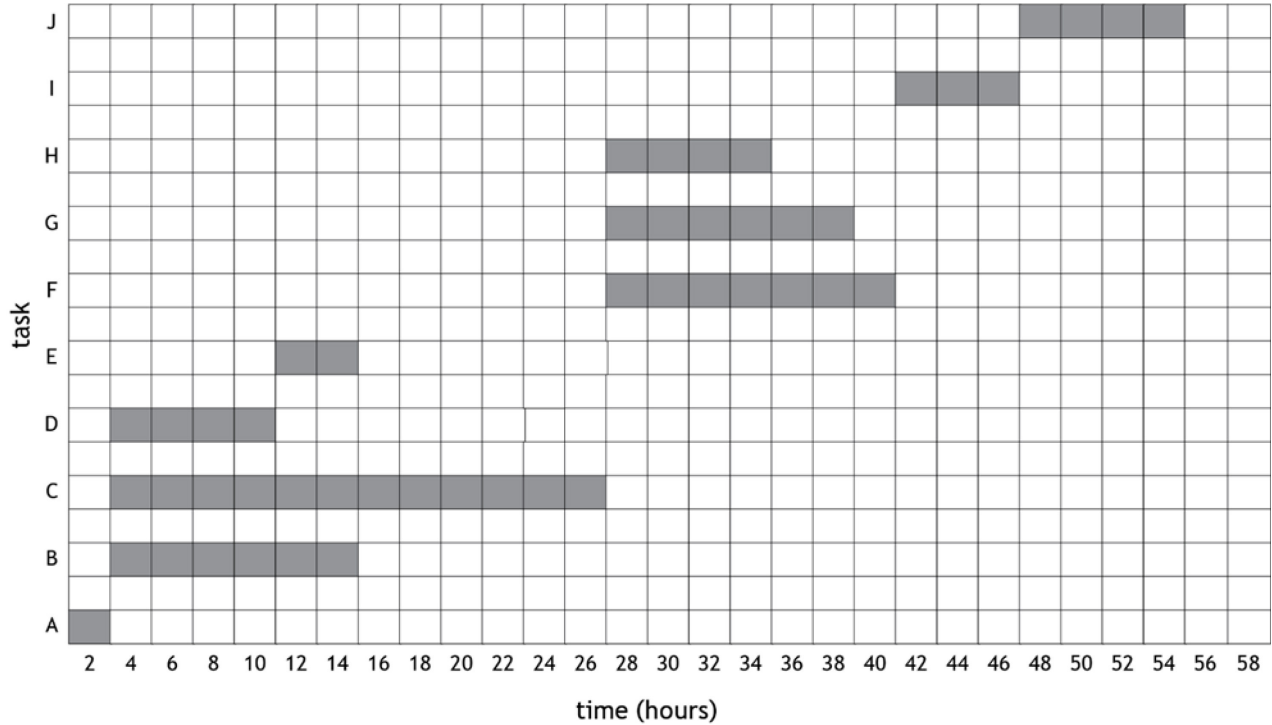

- All labels must be added to Gantt chart for •<sup>6</sup>, no need for the tasks axis to have the label activities but tasks A to J must be clearly labelled.
- Gantt chart must be consistent either with the candidate's PERT chart or the original table of tasks/times.
- Check that E is in the correct position.

**Commonly Observed Responses:**

(c)	<ul style="list-style-type: none"> <li>•<sup>9</sup> state critical path</li> <li>•<sup>10</sup> state minimum time</li> </ul>	<ul style="list-style-type: none"> <li>•<sup>9</sup> A C F I J</li> <li>•<sup>10</sup> 54 hours</li> </ul>	2
-----	--	--	---

**Notes:**

- Critical path must be consistent with PERT or Gantt chart.
- Incorrect critical path with evidence of summation of task times, award •<sup>10</sup> only.

**Commonly Observed Responses:**

(d)	• <sup>11</sup> determine maximum time	• <sup>11</sup> 14 hours	1
-----	--	--------------------------	---

**Notes:**

- Only penalise missing or incorrect units once between parts (c) and (d).

**Commonly Observed Responses:**

Question		Generic scheme	Illustrative scheme	Max mark
4.	(a)	<ul style="list-style-type: none"> <li>•<sup>1</sup> calculate appropriate level of CO<sub>2</sub> at end of day in cell D9</li> <li>•<sup>2</sup> create formula for CO<sub>2</sub> at end of day 1</li> <li>•<sup>3</sup> fill down to calculate level of CO<sub>2</sub> at the end of day 30</li> </ul>	<ul style="list-style-type: none"> <li>•<sup>1</sup> eg = 1 - D8</li> <li>•<sup>2</sup> appropriate formula in cell C15 eg = <math>\\$D\\$9 * C14 + \\$D\\$10</math></li> <li>•<sup>3</sup> 1394.05... (ppm)</li> </ul>	3

**Notes:**

1. If ROUND function has been used leading to 1394 (ppm) award ✓✓✓
2. If INT function has been used leading to 1390 (ppm) award ✓x✓<sub>1</sub>

**Commonly Observed Responses:**

	(b)	<ul style="list-style-type: none"> <li>•<sup>4</sup> extend spreadsheet to at least day 60</li> <li>•<sup>5</sup> construct appropriate graph to at least day 60</li> <li>•<sup>6</sup> appropriate title and axes labels</li> </ul>	<ul style="list-style-type: none"> <li>•<sup>4</sup> evidence of 1384.76... (ppm) at day 60</li> <li>•<sup>5</sup> (see below)</li> <li>•<sup>6</sup> (see below)</li> </ul>	3
--	-----	--	--	---

**Notes:**

CO<sub>2</sub> levels in kitchen showroom

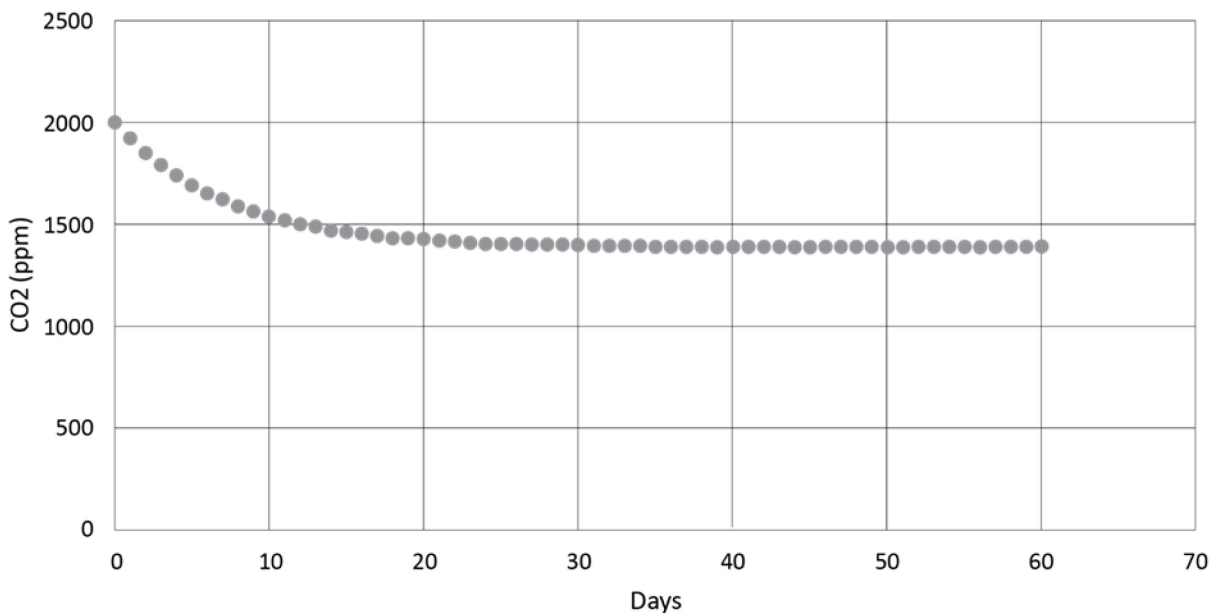

1. If ROUND function has been used leading to 1388 (ppm) award •<sup>4</sup>
2. If INT function has been used leading to 1384 (ppm) award •<sup>4</sup>

**Commonly Observed Responses:**

Question		Generic scheme	Illustrative scheme	Max mark
4.	(c)	<ul style="list-style-type: none"> <li>•<sup>7</sup> state conclusion with appropriate reason</li> </ul>	<ul style="list-style-type: none"> <li>•<sup>7</sup> eg the large dracaena plants are not effective at obtaining very good air quality in the showroom because the concentration of CO<sub>2</sub> remains above 800 ppm</li> </ul>	1
<p><b>Notes:</b></p> <ol style="list-style-type: none"> <li>Answers must reference the 800 ppm from the data booklet, and in context regarding the CO<sub>2</sub> levels/air quality.</li> <li>Where the printouts are not supplied and the candidate answer references one of the values from (a) or (b), •<sup>7</sup> can be awarded.</li> </ol>				
<p><b>Commonly Observed Responses:</b></p>				

Question		Generic scheme	Illustrative scheme	Max mark
5.	(a)	<ul style="list-style-type: none"> <li>•<sup>1</sup> evidence of first accumulation</li> <li>•<sup>2</sup> evidence of second accumulation</li> <li>•<sup>3</sup> calculate third accumulation and balance</li> </ul>	<ul style="list-style-type: none"> <li>•<sup>1</sup> eg <math>\times 1.00415</math></li> <li>•<sup>2</sup> eg <math>\times 1.047^{\frac{9}{12}}</math></li> <li>•<sup>3</sup> eg <math>\times 1.026^2</math> and (£)4964.36</li> </ul>	3

**Notes:**

1. Candidates must work to least two decimal places throughout.
2. Final answer must be to two decimal places, ignore any rounding errors or truncation.

**Commonly Observed Responses:**

**Candidate A**

Consistent error and working eased

$$4500 \times 0.415^3 \times 4.7^{\frac{9}{12}} \times 2.6^2 = 6940.28 \quad \bullet^1 \times \bullet^2 \times \bullet^3 \checkmark_1$$

**Candidate B**

Errors in time intervals

$$4500 \times 1.00415^4 \times 1.047^{\frac{8}{12}} \times 1.026^2 = 4965.93 \quad \bullet^1 \times \bullet^2 \times \bullet^3 \checkmark_1$$

	(b)	• <sup>4</sup> calculate deposit	• <sup>4</sup> (£) 5699.76	1
--	-----	----------------------------------	----------------------------	---

**Notes:**

1. Accept answers that round to (£)5700 with appropriate working.

**Commonly Observed Responses:**

**Candidate A**

Error in multiplier from part (a)

$$(a) \quad 4500 \times 0.415^3 \times 4.7^{\frac{9}{12}} \times 2.6^2 = 6940.28$$

$$(b) \quad \frac{6000}{2.6^2} = 887.57 \quad \bullet^4 \checkmark_1$$

Question			Generic scheme	Illustrative scheme	Max mark
6.	(a)	(i)	<ul style="list-style-type: none"> <li>•<sup>1</sup> generate measures of location and spread</li> <li>•<sup>2</sup> state means and standard deviations</li> </ul>	<ul style="list-style-type: none"> <li>•<sup>1</sup> output from software (see below)</li> <li>•<sup>2</sup> see note 2</li> </ul>	2

**Notes:**

1.  
`> mean(current)`                      `> mean(new)`  
 [1] 270.275                                [1] 267.5  
`> sd(current)`                              `> sd(new)`  
 [1] 8.752985                                [1] 9.896904

2.

	Measure of location (metres)	Measure of spread (metres)
Current golf ball	270.275	8.752985
New golf ball	267.5	9.896904

3.

	• <sup>1</sup> mean	• <sup>2</sup> standard deviation
• <sup>1</sup> generate output	<code>&gt; mean(current)</code> [1] 270.275 <code>&gt; mean(new)</code> [1] 267.5	<code>&gt; sd(current)</code> [1] 8.752985 <code>&gt; sd(new)</code> [1] 9.896904
• <sup>2</sup> correctly stated in table	270.275 and 267.5	8.752985 and 9.896904

**Commonly Observed Responses:**

Question			Generic scheme	Illustrative scheme	Max mark
6.	(a)	(ii)	<ul style="list-style-type: none"> <li>•<sup>3</sup> appropriate comment regarding location</li> <li>•<sup>4</sup> appropriate comment regarding spread</li> </ul>	<ul style="list-style-type: none"> <li>•<sup>3</sup> eg on <b>average</b>, the <b>distances</b> travelled by the new golf ball are less</li> <li>•<sup>4</sup> eg the <b>distances</b> travelled by the new golf ball are more <b>varied</b> than those travelled by the current golf ball</li> </ul>	2
<b>Notes:</b>					
<b>Commonly Observed Responses:</b>					
<p>Accept for location</p> <ol style="list-style-type: none"> <li>1. on <b>average</b>, the <b>distances</b> travelled by the current golf ball are more</li> <li>2. the new ball does not go as far on average</li> </ol> <p>Accept for spread</p> <ol style="list-style-type: none"> <li>1. the <b>distances</b> travelled by the current golf ball are more <b>consistent</b> than those travelled by the new golf ball</li> <li>2. the new ball drives vary in distance more than the current ball</li> <li>3. the new ball's distance are wider spread</li> </ol> <p>Do not accept for location</p> <ol style="list-style-type: none"> <li>1. the current balls drive further shown by the higher mean</li> <li>2. on average the current balls are longer</li> </ol> <p>Do not accept for spread</p> <ol style="list-style-type: none"> <li>1. the standard deviation is higher for the new ball compared to the current ball which shows on average the new ball had a wider spread</li> <li>2. the new ball's are wider spread</li> </ol>					
	(b)		<ul style="list-style-type: none"> <li>•<sup>5</sup> state the null and alternative hypotheses</li> </ul>	<ul style="list-style-type: none"> <li>•<sup>5</sup> null: there is no <b>difference</b> in the mean <b>distances</b> travelled by the current and the new golf balls.</li> <li>alternative: there is a <b>difference</b> in the mean <b>distances</b> travelled by the current and the new golf balls.</li> </ul>	1
<b>Notes:</b>					
<b>Commonly Observed Responses:</b>					



Question		Generic scheme	Illustrative scheme	Max mark
7.	(a)	<ul style="list-style-type: none"> <li>•<sup>1</sup> income NI payable on</li> <li>•<sup>2</sup> calculate NI contribution using 12% or 10% or 2% for one month</li> <li>•<sup>3</sup> complete calculation for NI contribution for one month</li> <li>•<sup>4</sup> calculate total NI contribution and total</li> </ul>	<ul style="list-style-type: none"> <li>•<sup>1</sup> (£)3141 and (£)311 stated or evidenced in •<sup>2</sup> or •<sup>3</sup>.</li> <li>•<sup>2</sup> (£)376.92 OR (£)314.10 OR (£)6.22</li> <li>•<sup>3</sup> (£)383.14 OR (£)320.32</li> <li>•<sup>4</sup> (£)4409.22 leading to (£)38,872.30</li> </ul>	4

**Notes:**

1.

NI band	Term	Income NI payable on	NI contribution
12%	9 months	£3141	£3392.28
10%	3 months	£3141	£942.30
2%	12 months	£311	£74.64
		Total NI contribution	£4409.22

2. If the 2% contribution is not considered •<sup>3</sup> is not available.

3. •<sup>4</sup> can only be awarded if at least two of the following are included in the calculation.

- 10% for 3 months
- 12% for 9 months
- 2% for 12 months

4. Final answer must be to two decimal places, ignore any rounding errors or truncation.

**Commonly Observed Responses:**

(b)	<ul style="list-style-type: none"> <li>•<sup>5</sup> interpret CPI</li> <li>•<sup>6</sup> state and interpret salary increase</li> </ul>	<ul style="list-style-type: none"> <li>•<sup>5</sup> <math>\frac{128.3}{119.0}</math> or equivalent</li> <li>•<sup>6</sup> No, since 7.1% is less than change in CPI</li> </ul>	2
-----	--	---	---

**Notes:**

1. No numerical comparison required, answer must be consistent with working.

**Commonly Observed Responses:**

**Candidate A**

$$\frac{(128.3 - 119)}{119} \times 100 = 7.8...%$$

•<sup>5</sup> ✓

$4200 \times 1.078... = (£)4528.24$  so his gross monthly income is lower than inflation

•<sup>6</sup> ✓

**Candidate B**

$$\frac{128.3}{4500} = 0.02851$$

•<sup>5</sup> ✓

$$\frac{119}{4200} = 0.0283 \text{ so no not in line with CPI}$$

•<sup>6</sup> ✓

Question			Generic scheme	Illustrative scheme	Max mark
8.	(a)		• <sup>1</sup> calculate the expected cost of a delay	• <sup>1</sup> $0.325 \times 75\,000 = (\pounds)24\,375$	1
<b>Notes:</b>					
<b>Commonly Observed Responses:</b>					
	(b)	(i)	• <sup>2</sup> calculate expected cost using control measure 1	• <sup>2</sup> $15\,000 + 0.25 \times 75\,000 = (\pounds)33,750$	1
		(ii)	• <sup>3</sup> calculate expected cost using control measure 2	• <sup>3</sup> $16\,000 + 0.1 \times 75\,000 = (\pounds)23,500$	1
<b>Notes:</b>					
<b>Commonly Observed Responses:</b>					
<b>Candidate A</b> Repeated error in probabilities $15\,000 + 0.1 \times 75\,000$ (i) $= (\pounds)22,500$ $16\,000 + 0.25 \times 75\,000$ (ii) $= (\pounds)34,750$			<b>Candidate B</b> Repeated error in additional costs $16\,000 + 0.25 \times 75\,000$ (i) $= (\pounds)34,750$ $15\,000 + 0.1 \times 75\,000$ (ii) $= (\pounds)22,500$		
	(c)		• <sup>4</sup> give valid explanation	• <sup>4</sup> control measure 2 because it is the cheapest	1
<b>Notes:</b> 1. Answer must be consistent with previous working.					
<b>Commonly Observed Responses:</b>					

Question		Generic scheme	Illustrative scheme	Max mark
9.	(a)	<ul style="list-style-type: none"> <li>•<sup>1</sup> calculate monthly interest rate</li> <li>•<sup>2</sup> create formulae for interest, capital repayment and mortgage outstanding</li> <li>•<sup>3</sup> complete remainder of mortgage schedule for 60 months</li> <li>•<sup>4</sup> calculate monthly repayment, and adjust final repayment</li> </ul>	<ul style="list-style-type: none"> <li>•<sup>1</sup> 0.287...%</li> <li>•<sup>2</sup> D16, E16, and F16(see spreadsheet)</li> <li>•<sup>3</sup> check cells C16-C75 and cells D75, E75, and F75</li> <li>•<sup>4</sup> £454.18 and £454.12 (using Goal Seek Function)</li> </ul> <p><b>OR</b></p> <ul style="list-style-type: none"> <li>•<sup>4</sup> £454.17 and £454.73 (using Goal Seek Function)</li> </ul>	4

**Notes:**

1. For marks •<sup>1</sup>, •<sup>2</sup> and •<sup>3</sup> see below

	Formula view	Numerical view
• <sup>1</sup>	$(1+C8)^{(1/12)}-1$	
• <sup>2</sup>	D16=ROUND(F15*\$C\$9,2), E16=C16-D16, F16=F15-E16	D16=71.77 E16=382.41 F16=24617.59
• <sup>3</sup>	C16-C74=level monthly repayment D75=ROUND(F74*\$C\$9,2), E75=C75-D75, F75=F74-E75	

2. If ROUND function has not been used •<sup>2</sup> is not available.

3. For an incorrect monthly interest rate, •<sup>1</sup> is not available but follow through working to award •<sup>2</sup>, •<sup>3</sup> and •<sup>4</sup>.

4. Do not award •<sup>1</sup> if 0.29 is entered into cell C9, leading to 454.79 or 454.57 in cell C15.

**Commonly Observed Responses:**

	(b)	(i)	• <sup>5</sup> state advantage	• <sup>5</sup> eg reduces the cost of your premium	1
		(ii)	• <sup>6</sup> any suitable response	• <sup>6</sup> eg When the damage claimed is less than the excess amount on your insurance policy  <b>OR</b>  eg when making a claim could increase the cost of your future premiums	1

Question			Generic scheme	Illustrative scheme	Max mark
9.	(b)	(ii)	(continued)		
<b>Notes:</b> 1. For ● <sup>5</sup> do not accept low premiums. 2. For ● <sup>6</sup> accept loss of no claims discount.					
<b>Commonly Observed Responses:</b>					
	(c)	(i)	● <sup>7</sup> complete schedule  ● <sup>8</sup> determine final repayment amount	● <sup>7</sup> complete schedule to zero balance (month 49)  ● <sup>8</sup> (£)427.19	2
		(ii)	● <sup>9</sup> calculate saving	● <sup>9</sup> (£)423.55 OR (£)423.57	1
<b>Notes:</b> 1. Answer for ● <sup>9</sup> must be consistent with ● <sup>4</sup> .					
<b>Commonly Observed Responses:</b>					

Question		Generic scheme	Illustrative scheme	Max mark
10.	(a)	<ul style="list-style-type: none"> <li>•<sup>1</sup> state type of relationship</li> </ul>	<ul style="list-style-type: none"> <li>•<sup>1</sup> (positive) linear</li> </ul>	1
<b>Notes:</b> 1. Accept direct proportion. 2. Accept correlation.				
<b>Commonly Observed Responses:</b>				
	(b)	<ul style="list-style-type: none"> <li>•<sup>2</sup> state numerical rate of change</li> <li>•<sup>3</sup> state correct units</li> </ul>	<ul style="list-style-type: none"> <li>•<sup>2</sup> 110</li> <li>•<sup>3</sup> millilitres per second</li> </ul>	2
<b>Notes:</b>				
<b>Commonly Observed Responses:</b>				
1. 330ml every 3 seconds 2. 55ml per 0.5 seconds 3. 1 can every 3 seconds 4. 3 seconds to fill 330ml can 5. 0.5 seconds each can will have 55ml 6. 50ml per 0.5 seconds				award ✓✓ award ✓✓ award ✓✓ award ✓x award ✓x award x✓
	(c)	<ul style="list-style-type: none"> <li>•<sup>4</sup> state assumption on number of hours production per week</li> <li>•<sup>5</sup> interpret rate for time to fill one can</li> <li>•<sup>6</sup> calculate number of cans per week</li> </ul>	<ul style="list-style-type: none"> <li>•<sup>4</sup> eg between 7 and 24 hours a day for 5 – 7 days</li> <li>•<sup>5</sup> 3 seconds</li> <li>•<sup>6</sup> eg  <math>100 \text{ cans per minute} \times 60</math>  <math>\times 7 \times 5 = 210\,000 \text{ (cans)}</math>  <b>OR</b>  <math>100 \text{ cans per minute} \times 60</math>  <math>\times 24 \times 7 = 1008\,000 \text{ (cans)}</math> </li> </ul>	3
<b>Notes:</b>				
<b>Commonly Observed Responses:</b>				

[END OF MARKING INSTRUCTIONS]